

STATE OF ILLINOIS
DEPARTMENT OF TRANSPORTATION

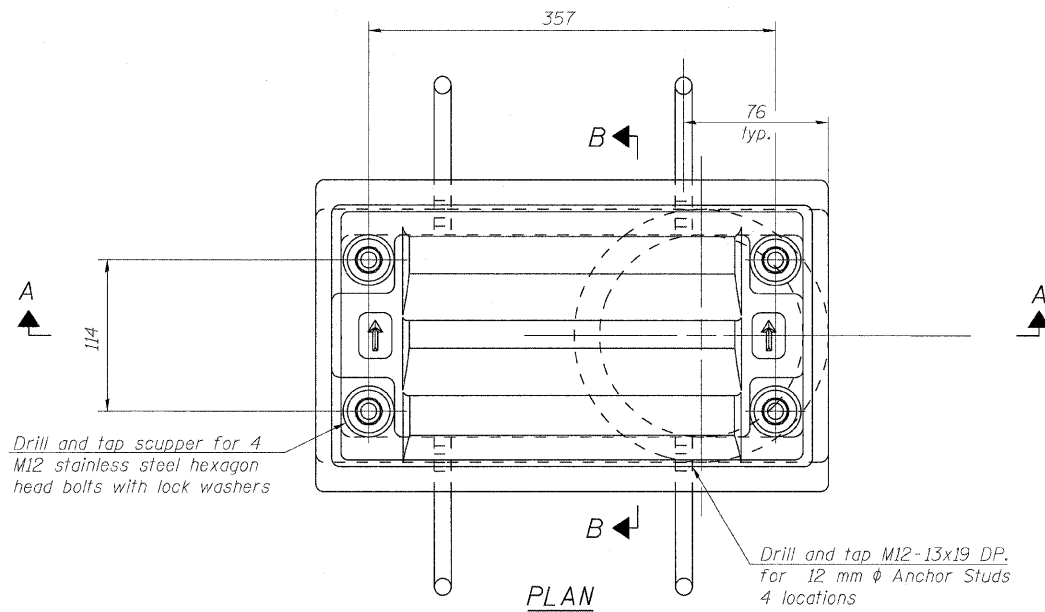

PLAN

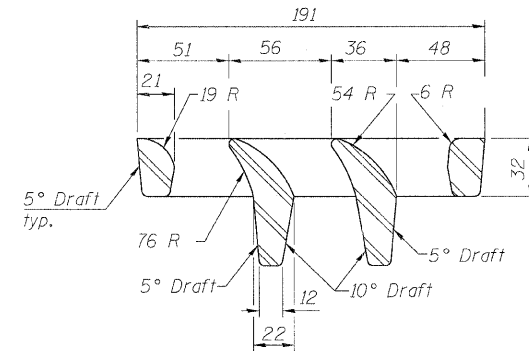

VANE GRATE DETAIL

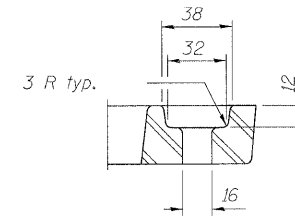

BOLT HOLE DETAIL

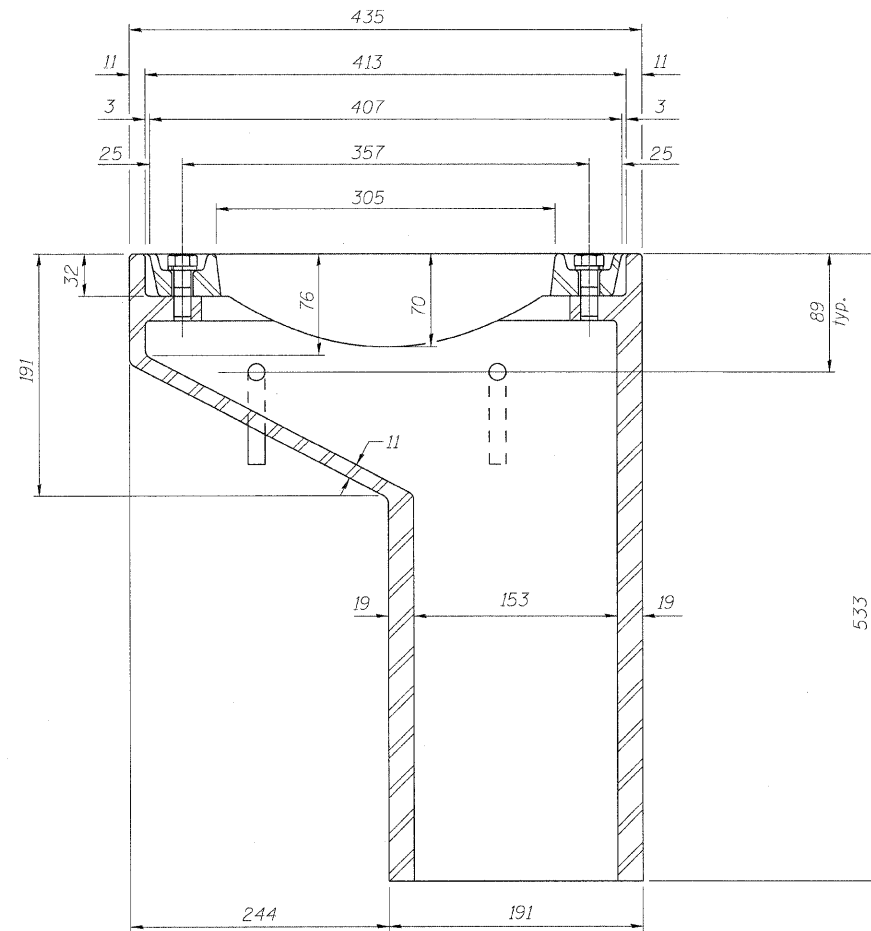

SECTION A-A

See sheet S-10 for scupper location relative to parapet.

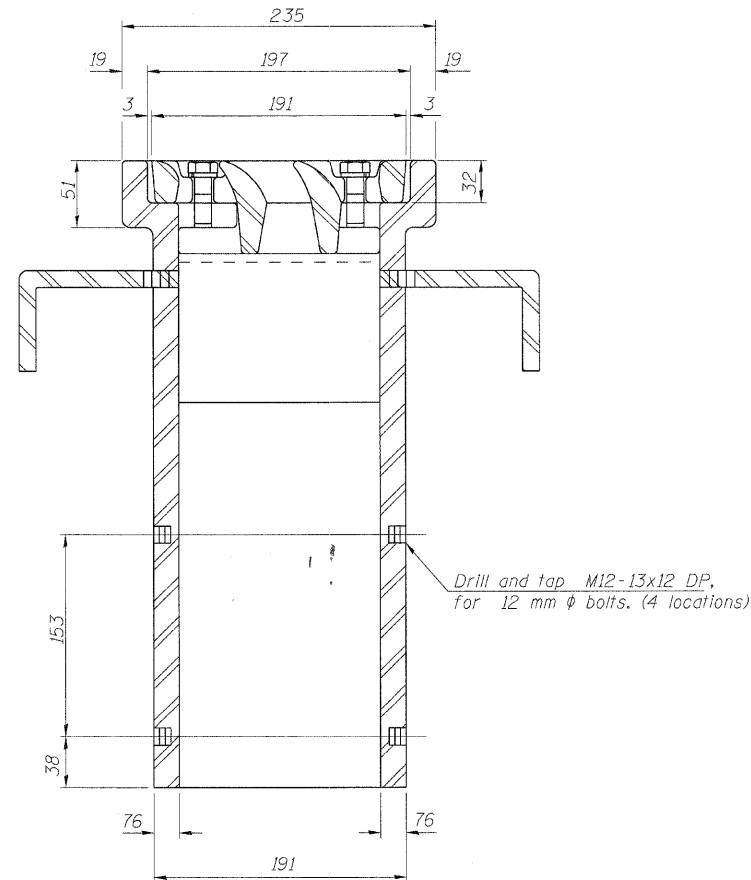

SECTION B-B

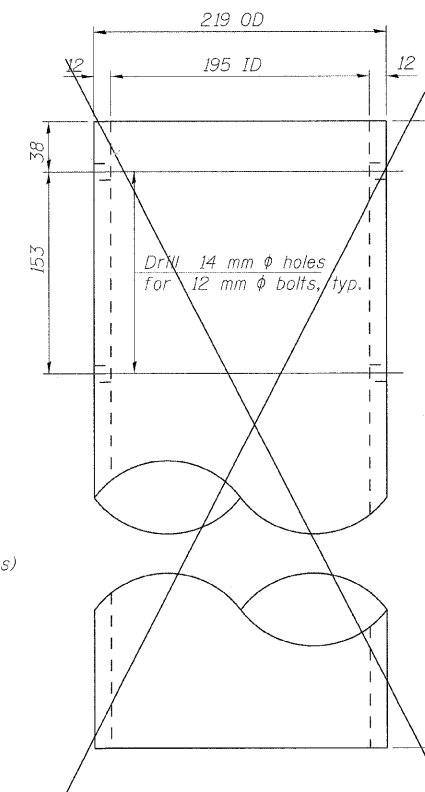

DOWNSPOUT

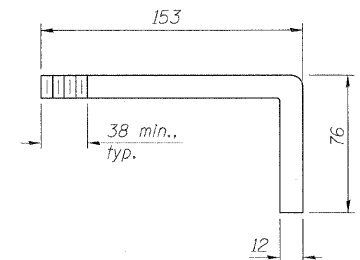

ANCHOR STUD DETAIL

BILL OF MATERIAL

ITEM	UNIT	QUANTITY
Drainage Scuppers, DS-11	Each	4

DRAINAGE SCUPPER, DS-11
STRUCTURE NO. 016-2034

SHEET NO. S-13	F.A.I. RTE.	SECTION	COUNTY	TOTAL SHEETS	SHEET NO.
S-26 SHEETS	57	1818.3B-R	COOK	58	37
			CONTRACT NO. 60862		
FED. ROAD DIST. NO.		ILLINOIS FED. AID PROJECT			

DESIGNED - EKM
CHECKED - SCD
DRAWN - RD
CHECKED - EKM



Ciorba Group, Inc.
CONSULTING ENGINEERS

5507 North Cumberland Avenue, Suite 402 Chicago, Illinois 60656
Tel. 773.775.4009 Fax 773.775.4014 Email chicago@ciorba.com