

PLAN - WITH SKEW

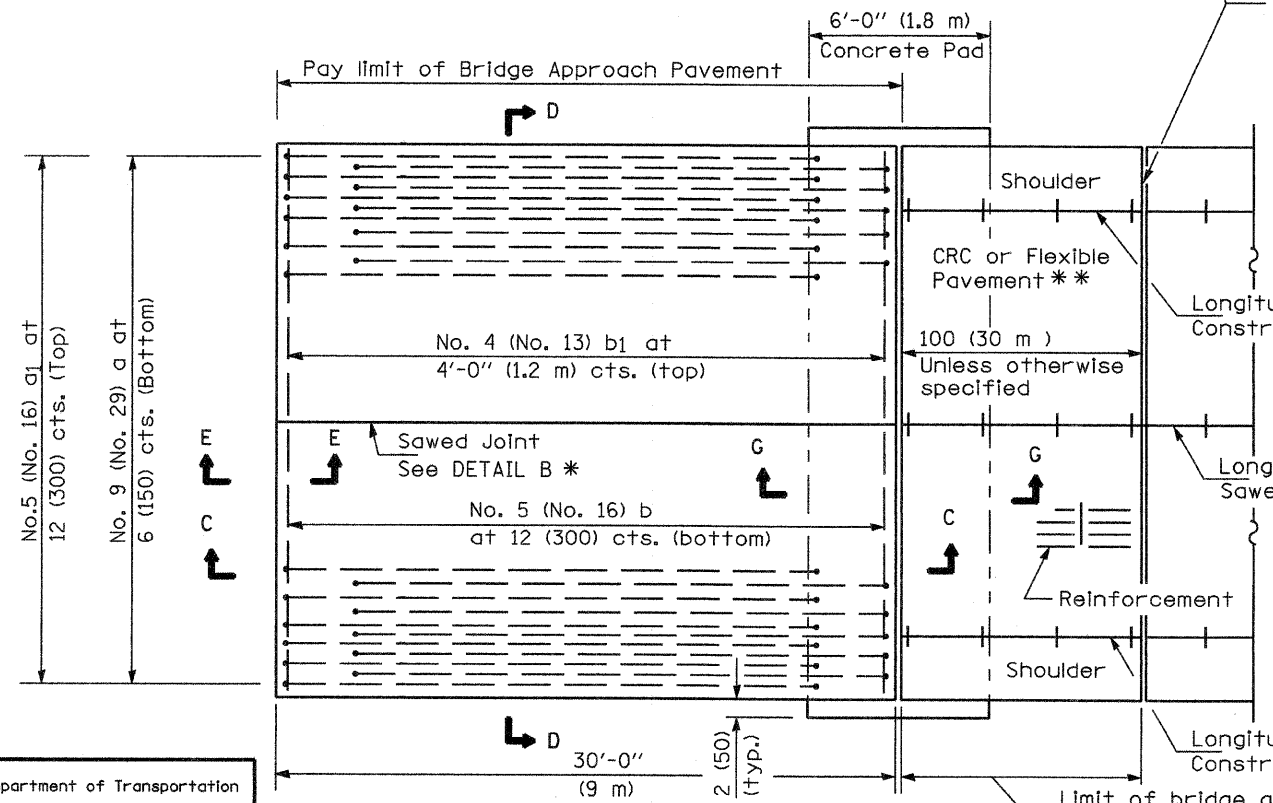

PLAN - WITHOUT SKEW

* Saw ϕ or lane edge if poured two or more lane widths at a time.
 ** Omit Reinforcement, tie bars and Long. sawed Jt. for Flexible Pavement.

NEW CONSTRUCTION

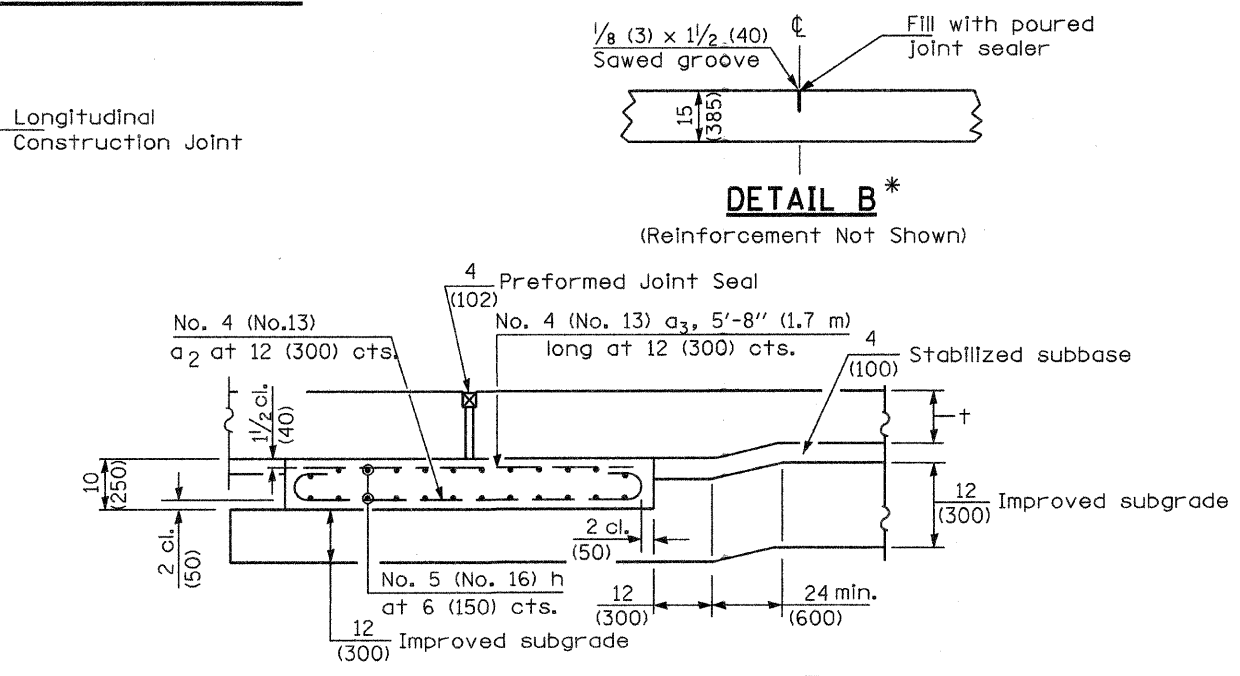

SECTION G-G - RIGID PAVEMENT

(Showing reinforcement)

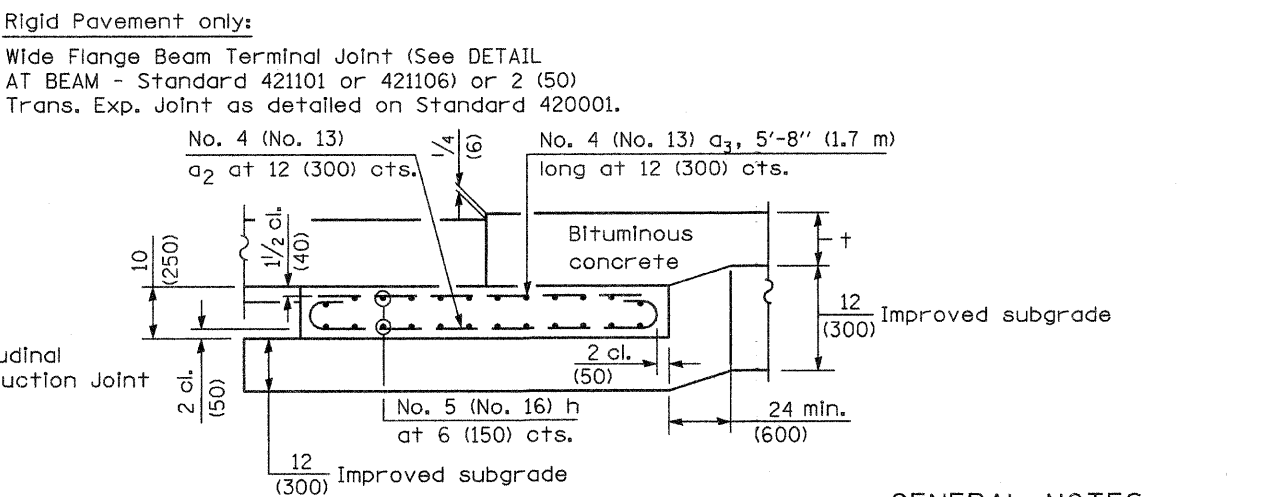

SECTION G-G - FLEXIBLE PAVEMENT

(Showing reinforcement)

GENERAL NOTES

THICKNESS-"+"=Thickness of Pavement.
 See Standard 421001 for reinforcement details not shown.
 See Standard 420001 for joint details not shown.
 All dimensions are in inches (millimeters) unless otherwise shown.

Illinois Department of Transportation
 APPROVED January 1, 2008
Ralph E. Anderson
 ENGINEER OF BRIDGES AND STRUCTURES
 APPROVED January 1, 2008
Law E. Hester
 ENGINEER OF DESIGN AND ENVIRONMENT
 ISSUED 1-1-97

DATE	REVISIONS
1-1-08	Switched units to English (metric). Moved rebar epoxy coat note to Standard Spec.
1-1-04	Rev. size of Trans. Exp. Jt. and soft converted metric reinf.

BRIDGE APPROACH PAVEMENT

(Sheet 1 of 4)

Contract 60862 Sheet 50A.