

AERIAL CABLE CONNECTION DETAIL

N.T.S.

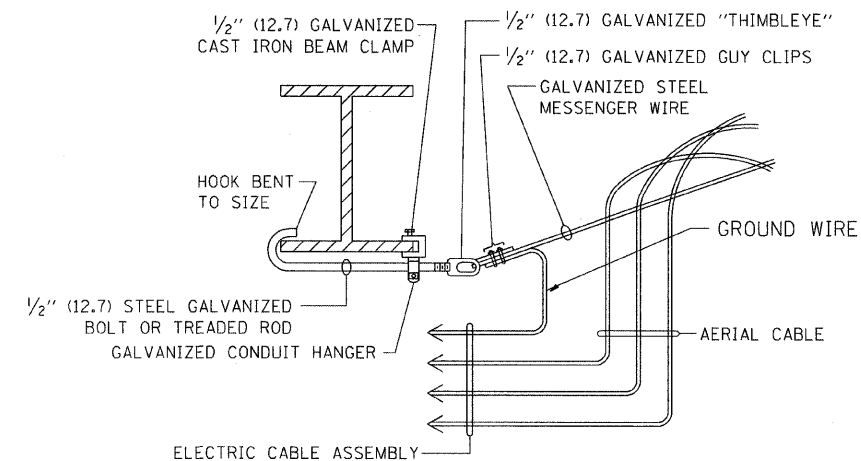

AERIAL CABLE ATTACHED TO STRUCTURE

NOT TO SCALE

NOTES:

1. ALL DIMENSIONS IN INCHES (MILLIMETERS) UNLESS OTHERWISE INDICATED.
2. SEE PROPOSED LIGHTING PLAN FOR CONDUIT, CABLE AND ROUTING.
3. THE CONTRACTOR SHALL PROVIDE INTERMEDIATE SUPPORTS TO MAINTAIN MINIMUM CLEARANCES. REFER TO AERIAL AERIAL CABLE ATTACHED TO STRUCTURE DETAIL.
4. COST OF SPLICES AND MOUNTING HARDWARE SHALL BE INCLUDED IN THE UNIT PRICE FOR AERIAL CABLE.

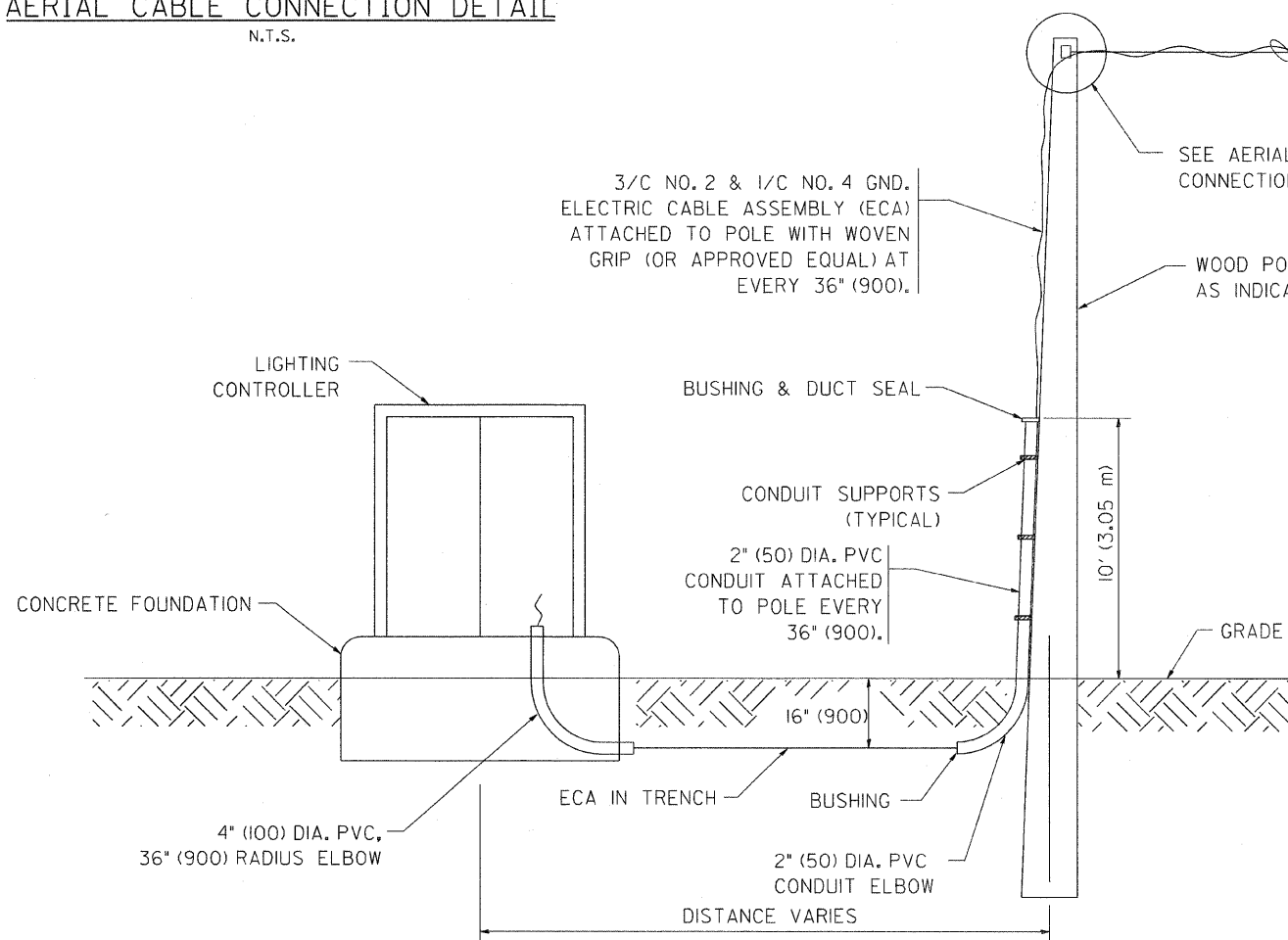

WOOD POLE TO LIGHTING CONTROLLER WIRING CONNECTION DETAIL

N.T.S.

FILE NAME = W:\diststd\22x34\be801.dgn	USER NAME = gegl:enobt	DESIGNED -	REVISED - 08-08-03	STATE OF ILLINOIS DEPARTMENT OF TRANSPORTATION	TEMPORARY AERIAL CABLE INSTALLATION	F.A.P. / R.T.E.	SECTION	COUNTY	TOTAL SHEETS	SHEET NO.
PLOT SCALE = 50,000 / IN.	DRAWN -	REVISED -	330			17 B-24-1	WILL	21	19	
PLOT DATE = 1/4/2008	CHECKED -	REVISED -	BE-801			CONTRACT NO. 60D79				
	DATE -	REVISED -	SCALE: NONE			SHEET NO. 1 OF 1 SHEETS		STA. 750+00 TO STA. 764+00		FED. ROAD DIST. NO. 1 ILLINOIS FED. AID PROJECT