

EXISTING TYPICAL SECTION
US 41 (SKOKIE BLVD.).

STATION:
43+13 TO 59+70
96+88 TO 114+24

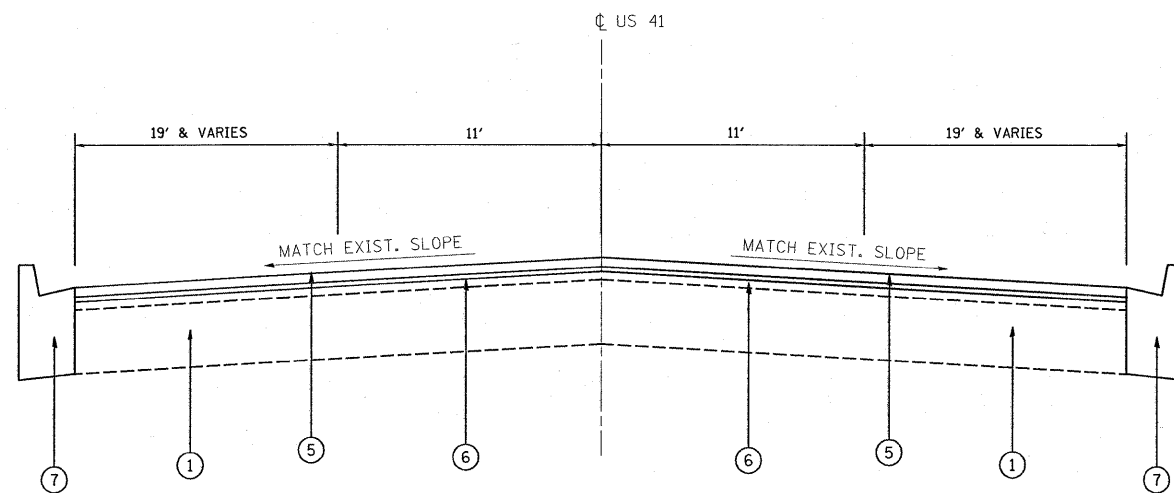

PROPOSED TYPICAL SECTION
US 41 (SKOKIE BLVD.).

STATION:
43+13 TO 59+70
96+88 TO 114+24

LEGEND

- ① EXIST. PCC BASE COURSE, 9''(±)
- ② EXIST. HOT-MIX ASPHALT SURFACE COURSE (BEFORE MILLING), 3''(±)
- ③ EXIST. CONCRETE CURB AND GUTTER
- ④ PROP. HOT-MIX ASPHALT SURFACE REMOVAL - 2 1/2''
(1/2'' OF HOT-MIX ASPHALT TO REMAIN)
- ⑤ PROP. POLYMERIZED HOT-MIX ASPHALT SURFACE COURSE, MIX "F",
N90, 1 3/4''
- ⑥ PROP. POLYMERIZED LEVELING BINDER (MM), IL-4.75, N50, 3/4''
- ⑦ PROP. CONCRETE CURB AND GUTTER REMOVAL AND REPLACEMENT
(LOCATIONS TO BE DETERMINED BY THE RESIDENT ENGINEER)

NOTES:

1. SEE ROADWAY AND PAVEMENT MARKING PLAN SHEETS FOR LOCATIONS OF LEFT TURN LANES, BARRIER MEDIANS AND CORRUGATED MEDIANS.
2. PAVEMENT PATCHING SHALL BE DONE PRIOR TO MILLING OF THE ROADWAY.

FILE NAME = c:\p\work\p\WIDOT\WILGREENDP\0104078\design_00.dgn	USER NAME = wlgreendp	DESIGNED -	REVISED -	STATE OF ILLINOIS DEPARTMENT OF TRANSPORTATION	US 41 / IL 50 (TOUHY AVE. TO FOSTER ST.) EXISTING AND PROPOSED TYPICAL SECTIONS		F.A.P. RTE. 350	SECTION 103RS-3	COUNTY COOK	TOTAL SHEETS 36	SHEET NO. 6
	PLOT SCALE = 50.0000' / IN.	CHECKED -	REVISED -				CONTRACT NO. 60FO1				
PLOT DATE = 1/10/2009	DATE -	REVISED -	SCALE:		SHEET NO. OF SHEETS	STA. TO STA.	FED. ROAD DIST. NO. 1 ILLINOIS FED. AID PROJECT				