

ROADWAY A STA. 88+47 TO STA. 122+75  
(LT. STA. 110+99.80 TO STA. 122+75 - GUARDRAIL SECTION)

LEGEND - EXISTING

- (A) 6" TO 9" GRANULAR SUB-BASE
- (B) 10" P.C.C. PAVEMENT
- (C) 5-3/4" & VAR BITUMINOUS OVERLAY
- (D) 4" PIPE UNDERDRAINS
- (E) VAR DEPTH BITUMINOUS SHOULDERS
- (F) 12" P.C.C. BASE COURSE
- (G) 12" SUB-BASE GRAN. MATERIAL TYPE A
- (H) EROSION CONTROL CURB
- (I) STEEL PLATE BEAM GUARDRAIL
- (J) GUARDRAIL AGGREGATE EROSION CONTROL

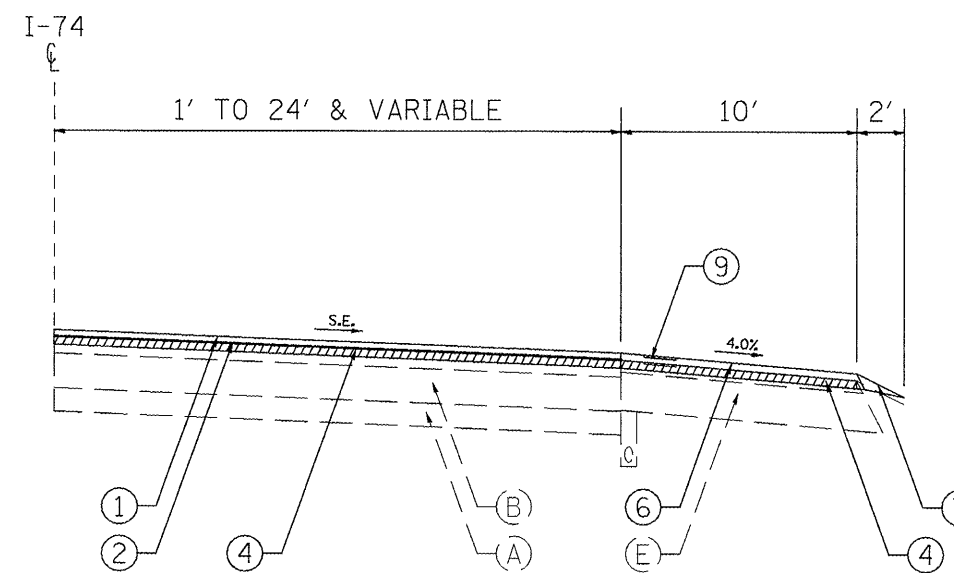

ROADWAY B STA. 14+42 TO STA. 49+71  
(RT. STA. 37+75 TO STA. 45+75 - GUARDRAIL SECTION)

LEGEND - PROPOSED

- ① POLYMERIZED HOT-MIX ASPHALT SURFACE CSE. 1-1/2"
- ② POLYMERIZED HOT-MIX ASPHALT BINDER CSE. 2-1/4"
- ③ POLYMERIZED LEVELING BINDER (MM) 3/4"
- ④ HOT-MIX ASPHALT SURFACE REMOVAL 2"
- ⑤ HOT-MIX ASPHALT SURFACE REMOVAL 1"
- ⑥ HOT-MIX ASPHALT SHOULDERS
- ⑦ AGGREGATE SHOULDERS TYPE B
- ⑧ PAVEMENT MARKING
- ⑨ RUMBLE STRIP
- ⑩ STEEL PLATE BEAM GUARDRAIL
- ⑪ GUARDRAIL AGGREGATE EROSION CONTROL

FILE NAME = Plan Sheets.dgn	USER NAME = torojs	DESIGNED -	REVISED -
		DRAWN -	REVISED -
		CHECKED -	REVISED -
		DATE -	REVISED -

**STATE OF ILLINOIS  
DEPARTMENT OF TRANSPORTATION**

<b>ROADWAY A &amp; ROADWAY B TYPICAL SECTIONS</b>	
SCALE:	SHEET NO. 6 OF 6 SHEETS
STA.	TO STA.

F.A.I. RTE.	SECTION	COUNTY	TOTAL SHEETS	SHEET NO.
74	72CSR5-2.5B-1.6RS-1J	PEORIA	59	14
CONTRACT NO. 68391				
ILLINOIS FED. AID PROJECT				