

SECTION A-A FOR EX EARTH/AGGREGATE FE

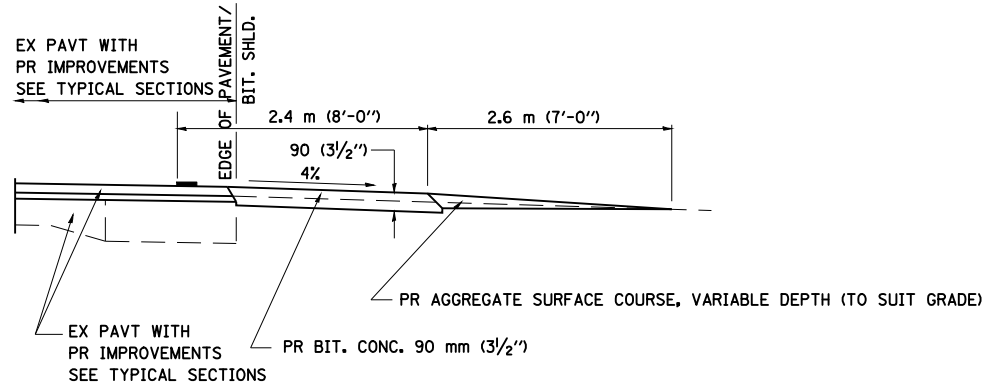

SECTION A-A FOR EX EARTH/AGGREGATE PE

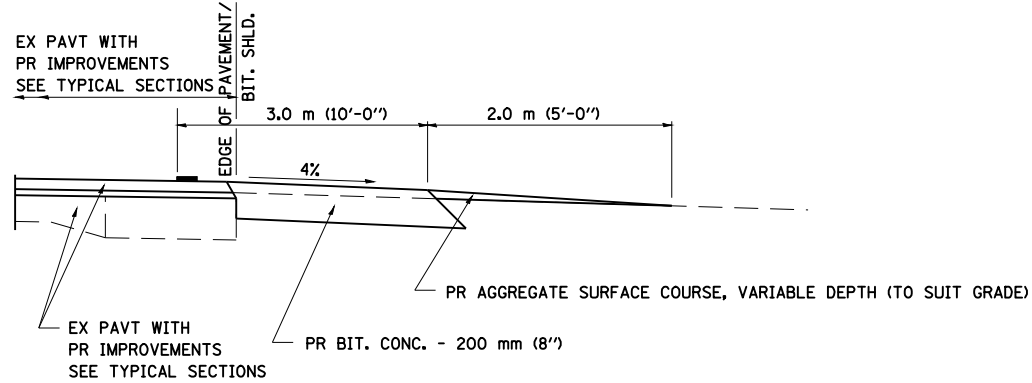

SECTION A-A FOR EX EARTH/AGGREGATE CE & SIDE ROAD

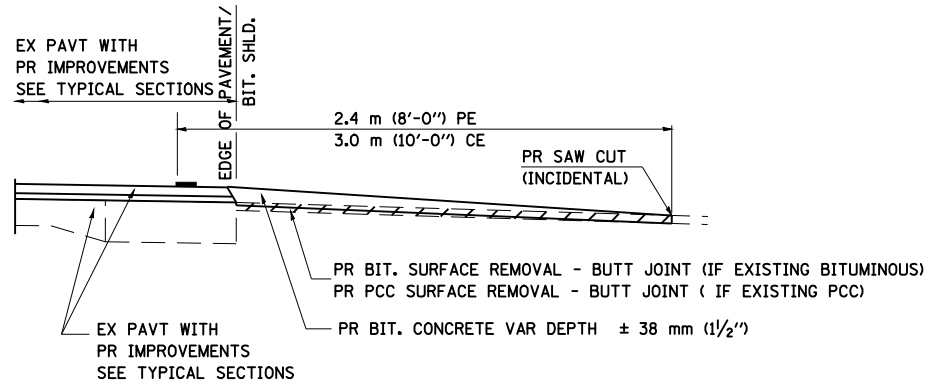

SECTION A-A FOR EX BITUMINOUS/ PC CONCRETE PE, CE & SIDE ROAD

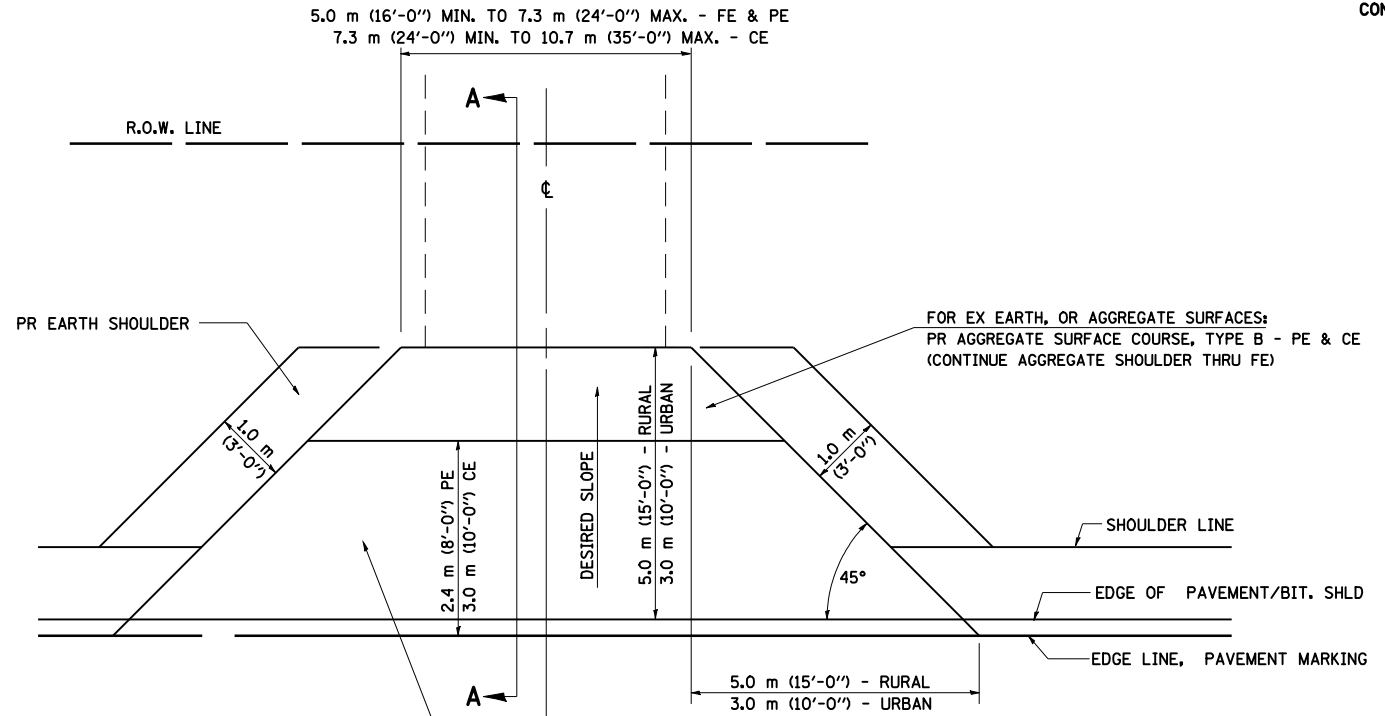

FOR EX EARTH OR AGGREGATE SURFACES:
 PR BIT SURFACE REMOVAL (IF APPLICABLE)
 PR AGGREGATE SHOULDER THRU - FE
 PR BITUMINOUS CONCRETE 90 mm (3 1/2") - PE
 PR BITUMINOUS CONCRETE 200mm (8") - CE

FOR EX BITUMINOUS CONCRETE SURFACES:
 PR BITUMINOUS SURFACE REMOVAL-BUTT JOINT

FOR EX PCC SURFACES:
 PR PCC SURFACE REMOVAL-BUTT JOINT

GENERAL NOTES:

THE RESIDENT ENGINEER WILL DETERMINE THE EXACT TYPE OF IMPROVEMENT TO BE COMPLETED FOR ALL ENTRANCES, SIDEROADS AND MAILBOX TURNOUTS ON THIS PROJECT.

THE PLAN DETAILS AND SCHEDULES SHOULD BE USED AS A GUIDE FOR THE ENGINEER TO IMPLEMENT THE FINAL DESIGN. THE ENGINEER MAY DECIDE TO SALVAGE PORTIONS OF THE EXISTING ENTRANCE PAVEMENT STRUCTURE; THEREFORE, REDUCING PAY ITEM QUANTITIES. NO ADDITIONAL PAYMENT WILL BE ALLOWED FOR THIS REDUCTION IN QUANTITIES.

ANY WORK THE ENGINEER REQUIRES WHICH IS NOT COVERED BY A PAY ITEM CONTAINED IN THE PLANS WILL BE PAID FOR IN ACCORDANCE WITH ARTICLE 109.04 OF THE STANDARD SPECIFICATIONS.

BITUMINOUS CONCRETE REQUIRED TO CONSTRUCT THE ENTRANCES SHALL BE IN ACCORDANCE WITH THE APPLICABLE PORTIONS OF SECTION 406 AND 408 OF THE STANDARD SPECIFICATIONS AND AS DIRECTED BY THE ENGINEER.

WHEN THE BITUMINOUS CONCRETE PROPOSED FOR THE IMPROVEMENT IS THICKER THAN 75 mm (3 INCHES) AND REQUIRE PLACEMENT IN MORE THAN ONE LIFT. THE BOTTOM LIFT(S) SHALL MEET THE REQUIREMENTS OF BITUMINOUS BASE COURSE IN SECTION 406 OF THE STANDARD SPECIFICATIONS AND THE TOP LIFT OF 50 mm (2 INCHES) SHALL MEET THE REQUIREMENTS OF BITUMINOUS CONCRETE SURFACE COURSE, SUPERPAVE.

THIS WORK WILL BE PAID FOR IN ACCORDANCE WITH SECTIONS 351, 358, 408, 423 AND 440 OF THE STANDARD SPECIFICATIONS.

ALL DIMENSIONS ARE IN MILLIMETERS (INCHES)
 UNLESS OTHERWISE SHOWN.

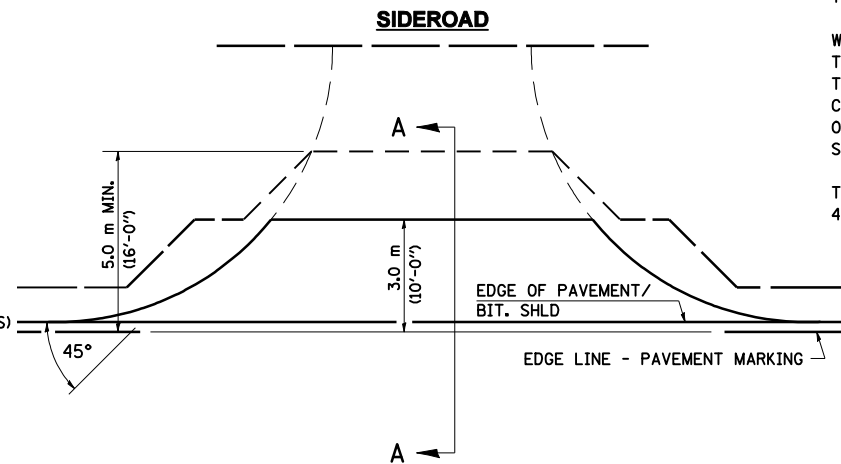

NOTE : IF BIT. SHLDS ARE PROPOSED THEY SHOULD NOT EXTEND THROUGH SIDEROADS

REVISIONS	
NAME	DATE
JCN	2/19/03

SHEET 1 OF 4
 ILLINOIS DEPARTMENT OF TRANSPORTATION
DISTRICT SIX
DETAILS FOR RURAL / URBAN
ENTRANCE, MAILBOX TURNOUT
& SIDEROADS
W / O CONCRETE GUTTER
(PPP - PROJECTS)

SCALE: VERT. DRAWN BY CADD
 HORIZ. CHECKED BY JCN
 DATE: FEBRUARY 23, 1999