

Section Type A
(Box end extension)

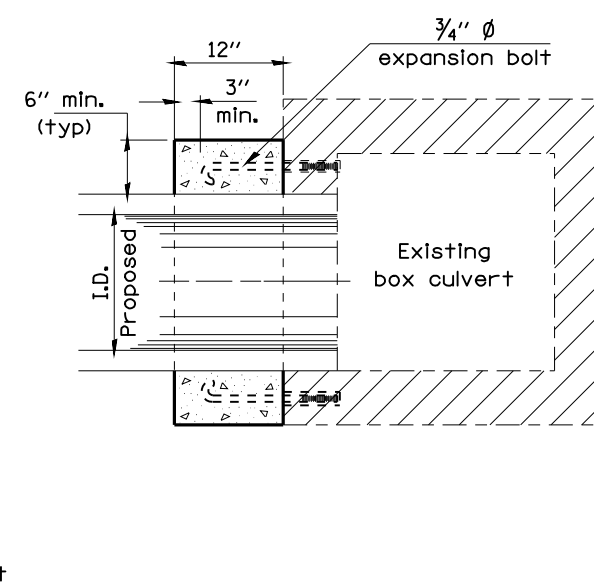

Section Type B
(Pipe in side extension)

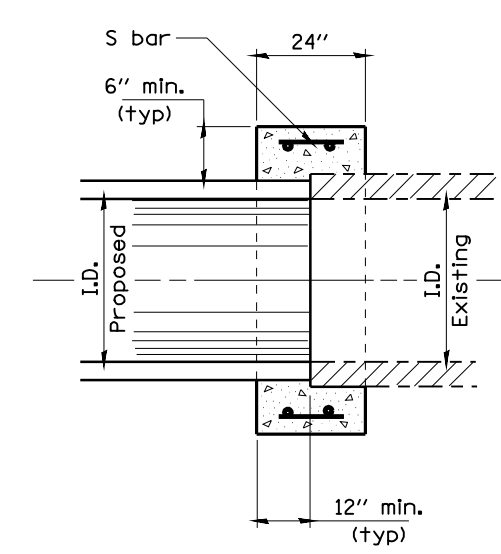

Section Type C
(Pipe end to pipe end extension
No expansion bolts required)

Section A - A

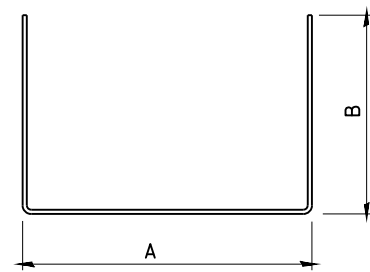

#5 U - bar

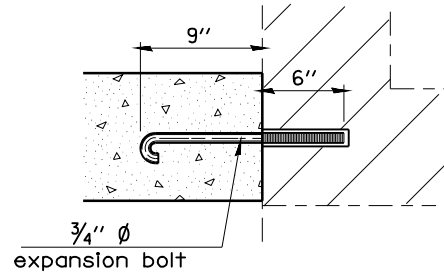

Expansion Bolt Detail

Notes:

- Expansion bolts shall consist of self drilling expansion shields and 3/4" ϕ hooked bolts. Hooked bolts shall extend a minimum of 9" into new concrete. Minimum Certified Proof Load - 2 ton
- Use minimum of 1 (one) expansion bolt at each corner.

Location	Station	Section Type	Skew	Existing Culvert Size	Proposed Culvert I.D.	Proposed Culvert O.D.	Collar		Reinforcement Bars										Expansion Bolts 3/4"	Concrete Collar cu yd
							Height	Width	S bar			U bar				(lb)				
									No.	Size	Length	No.	Size	A	B		Lap	Length		
IL 104	306+34 RT	A	0°	2' x 2'	24"	30"	42"	42"	-	-	-	4	#5	36"	27"	18	90"	31.3	4	0.27
Total																	31.3	4	0.27	