

STATE OF ILLINOIS
DEPARTMENT OF TRANSPORTATION

ROUTE NO.	SECTION	COUNTY	TOTAL SHEETS	SHEET NO.	SHEET NO. 2 8 SHEETS
F.A.P. 778	(2-B)-1	SALINE	74	14	
FED. ROAD DIST. NO. *	ILLINOIS	FED. AID PROJECT			

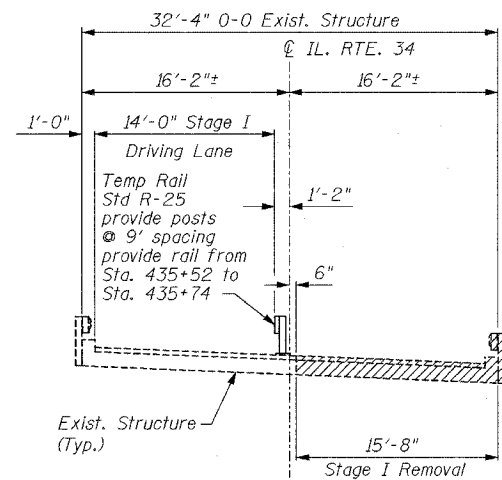

STAGE I REMOVAL
Looking East

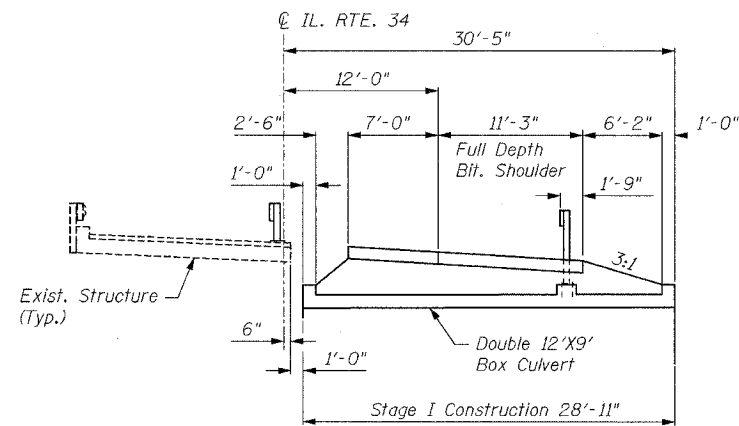

STAGE I CONSTRUCTION
Looking East

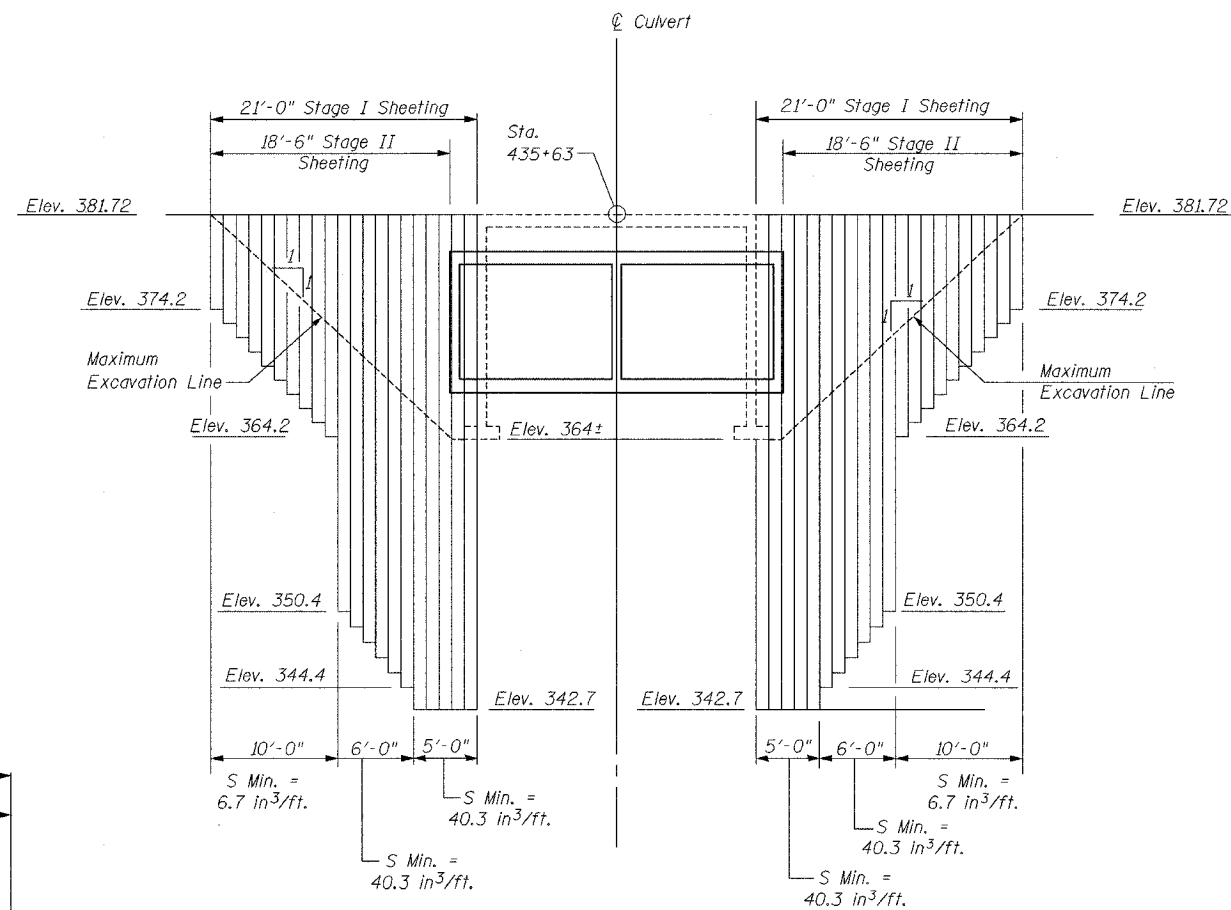

TEMPORARY STEEL SHEET PILING
Looking North

Note:
If the Contractor chooses to alter the temporary cantilevered sheet piling design requirements shown on the plans, a design submittal including plan details and calculations will be required for review and acceptance by the Engineer.

The Contractor shall connect the first sheet to the existing abutment wall to ensure stability of sheets driven to the top of the existing footing. This connection shall be reviewed and accepted by the Engineer and included in the cost of Temporary Sheet Piling.

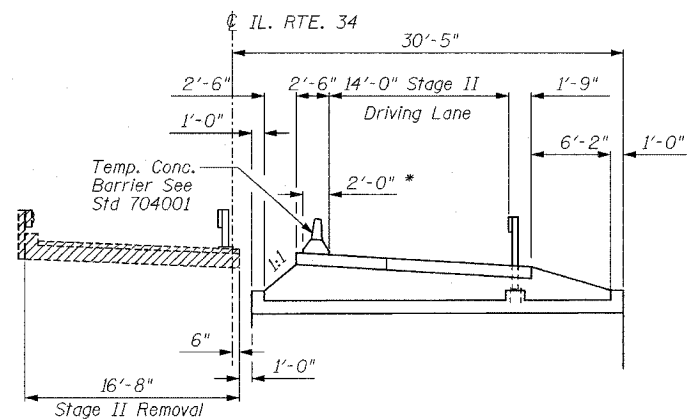

STAGE II REMOVAL
Looking East

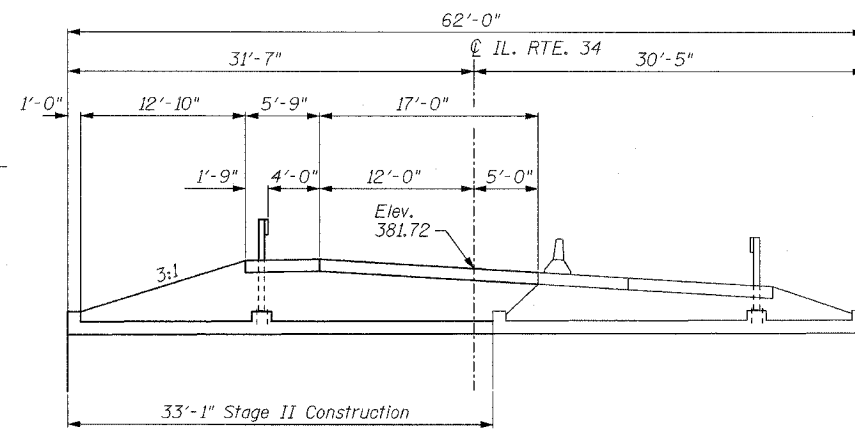

STAGE II CONSTRUCTION
Looking East

* Based on NJ shape Temp. concrete barrier

DESIGNED	SBM
CHECKED	KMN
DRAWN	MSJ
CHECKED	WCC

**STAGE CONSTRUCTION AND
TEMP. SHEET PILING DETAILS
IL. ROUTE 34 OVER UNNAMED TRIBUTARY
TO SOUTH FORK SALINE RIVER
FAP ROUTE 778 - SEC. (2-B)-1
SALINE COUNTY
STATION 435+63
STRUCTURE NO. 083-2015**