

SECTION B-B

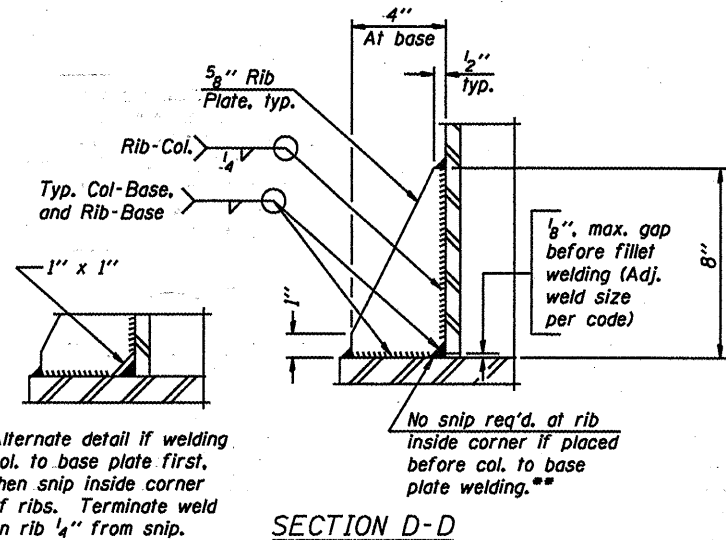

SECTION D-D

•• Alternate detail if welding col. to base plate first, then snip inside corner of ribs. Terminate weld on rib 1/4 inch from snip.

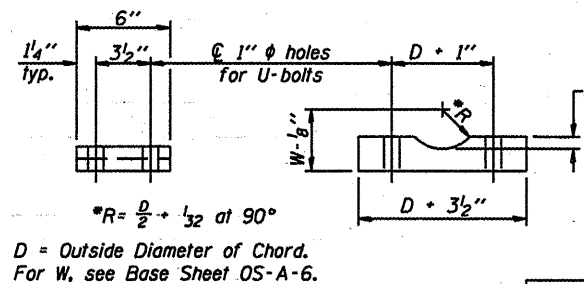

SADDLE SHIM DETAIL
ASTM B26 Alloy 356-F
or
ASTM B209 Alloy 6061-T651
(4 required per sign truss)

Truss Chord Nominal Dia.	a
5"	3/4"
5 1/2"	13/16"
6"	7/8"
6 1/2"	15/16"
7"	1"

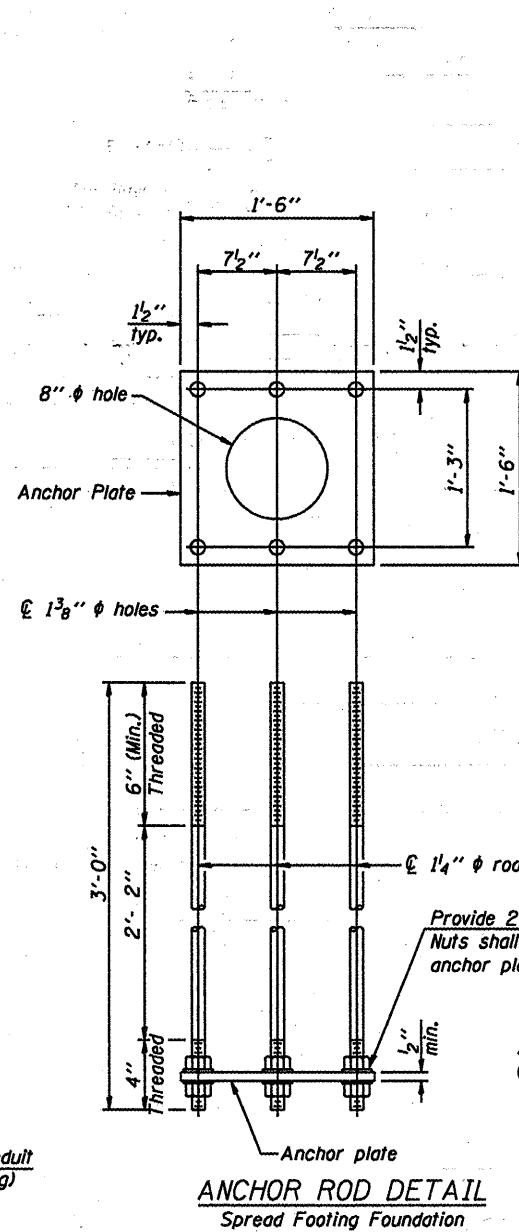

ANCHOR ROD DETAIL
Spread Footing Foundation

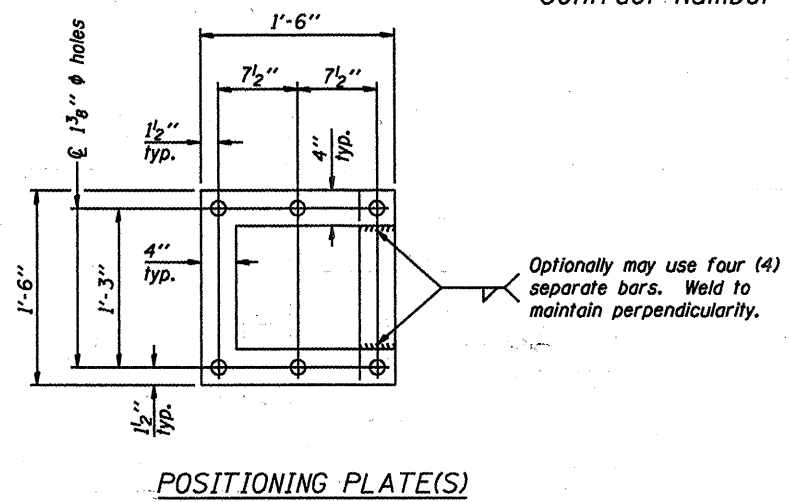

POSITIONING PLATE(S)

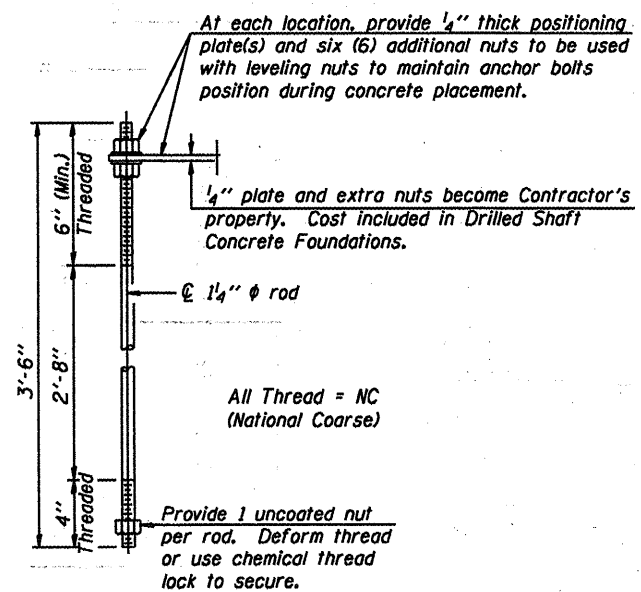

ANCHOR ROD DETAIL
Drilled Shaft Foundation

Anchor rods shall conform to AASHTO M314 Grade 36 or 50 and meet Charpy V-Notch (CVN) energy of 15 lb.-ft. at 40° F. Galvanize upper 12" per AASHTO M232. No welding shall be permitted on rods.

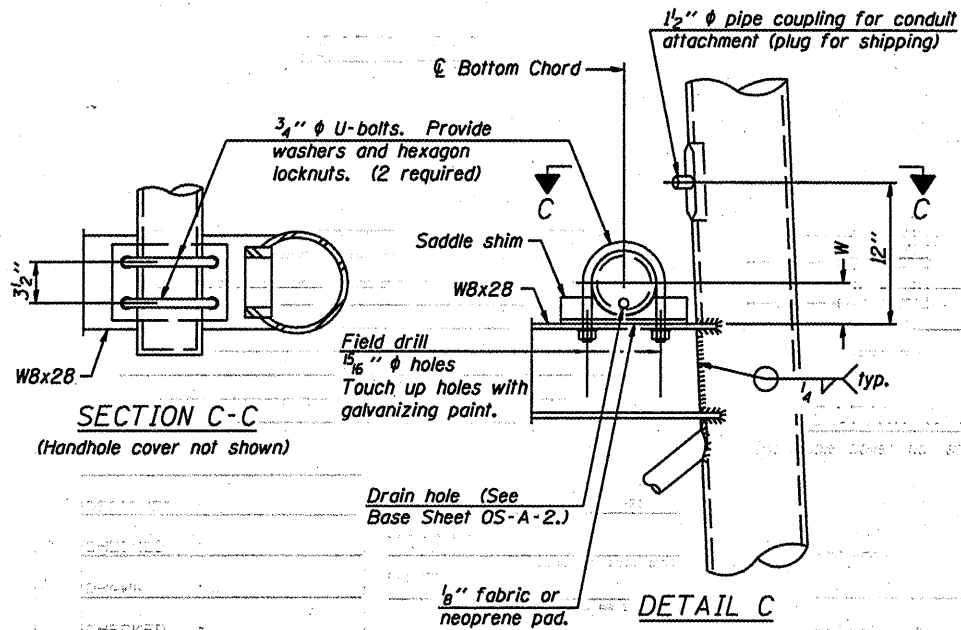

SECTION C-C
(Handhole cover not shown)

DETAIL C

10" PH PIPE SUPPORT FRAME DETAILS

NUMBER	REVISION	DATE

DESIGNED -	20
CHECKED -	EXAMINED
DRAWN -	PASSED
CHECKED -	ENGINEER OF BRIDGE DESIGN
	ENGINEER OF BRIDGES AND STRUCTURES

OVERHEAD SIGN STRUCTURES
SUPPORT FRAME DETAILS ALUMINUM TRUSS

District 1
Overhead Sign Structure
Repair & Replacement