

EXISTING TYPICAL CROSS SECTION

STA. 4+19 TO 57+00

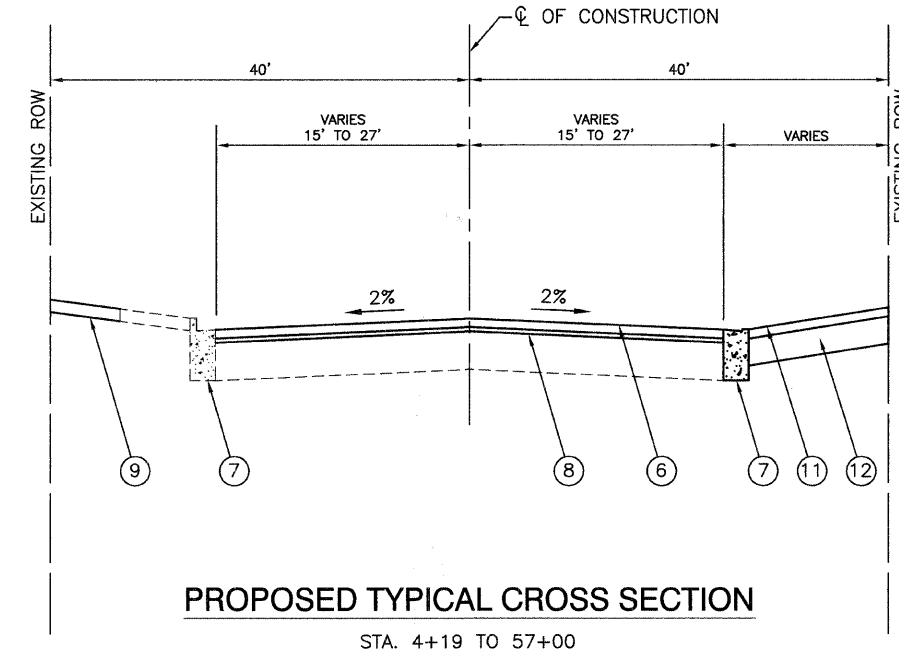

PROPOSED TYPICAL CROSS SECTION

STA. 4+19 TO 57+00

- 1 EXISTING CURB & GUTTER TO BE REMOVED AT LOCATIONS AS SHOWN ON PLANS OR DIRECTED BY ENGINEER
- 2 HOT-MIX ASPHALT SURFACE REMOVAL, 2"
- 3 EXISTING BITUMINOUS BASE COURSE TO REMAIN, ±10"
- 4 EXISTING P.C. CONCRETE SIDEWALK TO BE REMOVED AT LOCATIONS AS SHOWN ON PLANS OR DIRECTED BY ENGINEER
- 5 EXISTING DRIVEWAY PAVEMENT TO BE REMOVED AT LOCATIONS AS SHOWN ON PLANS OR DIRECTED BY ENGINEER
- 6 HOT-MIX ASPHALT SURFACE COURSE, MIX D, N70 1½"
- 7 COMBINATION CONCRETE CURB & GUTTER, B6.12 AT LOCATIONS AS SHOWN ON PLANS OR DIRECTED BY ENGINEER
- 8 POLYMERIZED LEVELING BINDER (MACHINE METHOD), IL-4.75, N50, 3/4"
- 9 PORTLAND CEMENT CONCRETE SIDEWALK, 5 INCH AT LOCATIONS SHOWN ON PLANS OR DIRECTED BY ENGINEER
- 10 PORTLAND CEMENT CONCRETE DRIVEWAY PAVEMENT AT LOCATIONS SHOWN ON PLANS OR DIRECTED BY ENGINEER
- 11 HOT-MIX ASPHALT SURFACE COURSE, MIX "C", N50, 2"
- 12 HOT-MIX ASPHALT BASE COURSE, 6"

HOT-MIX ASPHALT MIXTURE REQUIREMENTS

MIXTURE TYPE	AC TYPE	AIR VOIDS
RESURFACING		
HOT-MIX ASPHALT SURFACE COURSE, MIX "D", N70(IL-9.5mm); 1 1/2"	PG 64-22	4% @ 70 Gyr.
POLYMERIZED LEVELING BINDER (MACHINE METHOD), IL-4.75, N50, 3/4"	SBS/SBR PG 76-28/-22	4% @ 70 Gyr.
DRIVEWAYS		
HOT MIX ASPHALT SURFACE COURSE, MIX "C", N50(IL-9.5mm); 2"	PG 64-22	4% @ 50 Gyr.
HOT MIX ASPHALT BASE COURSE, (HMA BINDER IL-19.0mm); 6"	PG 64-22 *	4% @ 50 Gyr.
PATCHING		
CLASS D PATCHES, TYPE II, III, IV, 6"	PG 64-22 *	4% @ 70 Gyr.

NOTE:
THE UNIT WEIGHT USED TO CALCULATE ALL HOT-MIX ASPHALT SURFACE MIXTURE QUANTITIES IS 112 LBS/SY/IN.
*WHEN RAP EXCEEDS 20%, THE NEW ASPHALT BINDER IN THE MIX SHALL BE PG 58-22.

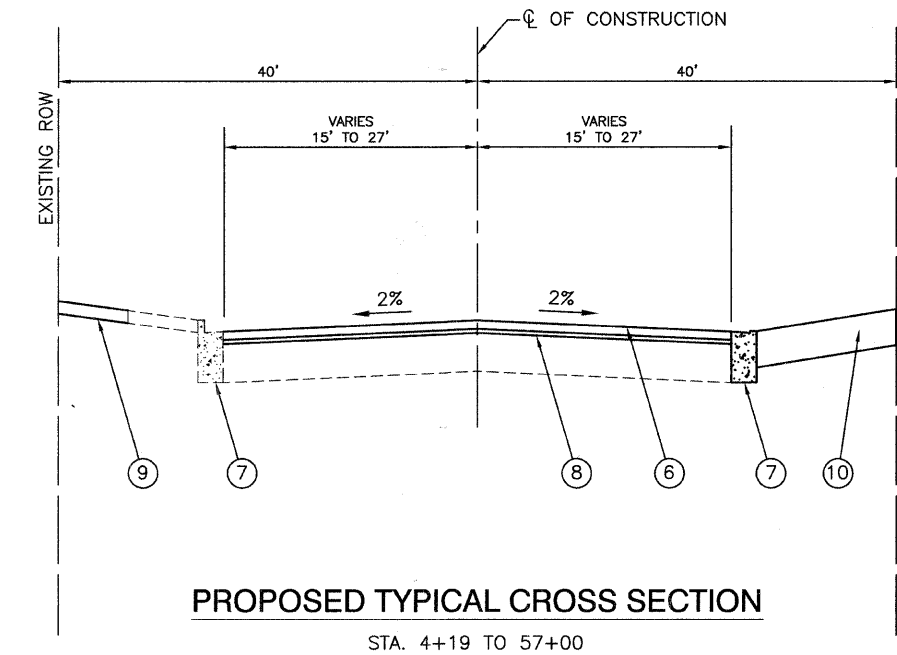

PROPOSED TYPICAL CROSS SECTION

STA. 4+19 TO 57+00

FILE NAME = 07485-TYPX-01 - P01

USER NAME =	DESIGNED -- RES	REVISED --
	CHECKED -- SLG	REVISED --
PLOT SCALE =	DRAWN -- SLG	REVISED --
PLOT DATE = 12/18/08	CHECKED -- SLG	REVISED --

**STATE OF ILLINOIS
DEPARTMENT OF TRANSPORTATION**

BROADWAY AVENUE TYPICAL SECTIONS PARK AVENUE TO SIBLEY BOULEVARD HARVEY, ILLINOIS		F.A.U. RTE. 1025	SECTION 08-00181-00-RS	COUNTY COOK	TOTAL SHEETS 10	SHEET NO. 3
SCALE: NONE	SHEET NO. 3 OF 10 SHEETS	STA. ---	TO STA. ---	CONTRACT NO. 63117		
		FED. ROAD DIST. NO. 1 ILLINOIS FED. AID PROJECT M-9003(180)				