

PLAN	SURVEYED	DATE
	PLAN NO.	
	CHECKED	
	BY	
	DATE	
	NO. OF SHEETS	
	NO. OF SHEETS CHECKED	
	DATE	
	BY	
	DATE	

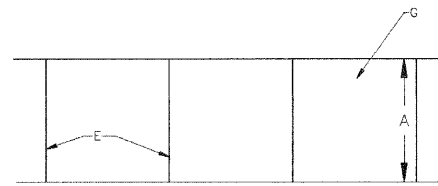

PLAN

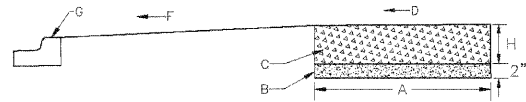

PROFILE

- CONSTRUCTION NOTES**
- 5' NORMAL WIDTH
 - CRUSHED STONE OR GRAVEL BASE
 - P.C.C. SIDEWALK
 - SLOPE 2" PER FOOT TO STREET SIDE
 - JOINTS, SEE NOTES 3 AND 4
 - SLOPE 2% TO 8% TOWARDS STREET
 - CURB AND GUTTER
 - CONCRETE THICKNESS, SEE NOTE 1.

- GENERAL NOTES**
- STANDARD THICKNESS OF CONCRETE SHALL BE A MINIMUM OF 5".
 - WHERE WOODEN FORMS ARE USED, 2"x4" ARE NOT ALLOWED. ONLY 2"x6" SHALL BE USED.
 - PREFORMED 3/4" EXPANSION JOINTS SHALL BE CONSTRUCTED AT A MAX. SPACING OF 50'.
 - FORMED OR SAW-CUT CONTRACTION JOINTS SHALL BE SPACED GENERALLY 5' APART, BUT NO LESS THAN 4' AND NO MORE THAN 6'.
 - 1/2" EXPANSION JOINTS SHALL BE INSTALLED WHERE SIDEWALK ADJUTS BUILDINGS, TRAFFIC SIGNAL FOUNDATIONS, SERVICE POLES, AND OTHER IMMOVABLE STRUCTURES.
 - CONCRETE TO BE 6-BAG MIX.

VILLAGE OF WESTMONT
STANDARD DETAIL
FOR
SIDEWALK

DATE: APRIL, 2008
DWG R-10-0

ISSUED: March 1998
REVISED: April 7, 2008

I:\WMNTV\GENERAL\Standards\dwgs\SIDEWALK.dwg

CONSTRUCTION NOTES

- STANDARD STEEL OR WOODEN FENCE POST
- STANDARD 48" HIGH SNOW FENCE

GENERAL NOTES

- PRIOR TO CLEARING A SITE, THE VILLAGE SHALL INSPECT THE SITE ALONG WITH THE DEVELOPER AND TAG THOSE TREES TO BE PROTECTED IN ACCORDANCE WITH THE PLAN.
- TREE PROTECTION SHALL BE MAINTAINED UNTIL FINAL GRADING AND RESTORATION OF ADJACENT AREAS.
- THE VILLAGE SHALL INSPECT AND APPROVE THE LOCATION OF ALL FENCING PRIOR TO CONSTRUCTION.
- ALL TREES TO BE RELOCATED AND TRANSPLANTED SHALL BE REMOVED PRIOR TO GRADING OF THE SITE. THE CONTRACTOR SHALL PROTECT ALL TRANSPLANTED TREES IN ACCORDANCE WITH THIS DETAIL, IN A SIMILAR MANNER TO THOSE TREES TAGGED TO BE SAVED.

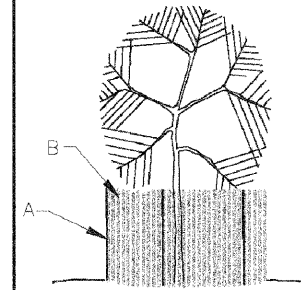

ELEVATION
NO SCALE

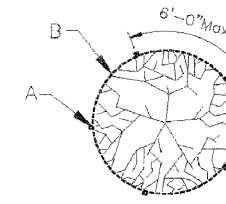

PLAN
NO SCALE

VILLAGE OF WESTMONT
STANDARD DETAIL
FOR
TREE PROTECTION

DATE: APRIL, 2008
DWG R-17-0

ISSUED: December 1996
REVISED: April 7, 2008

I:\WMNTV\GENERAL\Standards\dwgs\TREE_PROT.dwg

PROFILE	SURVEYED	DATE
	PLAN NO.	
	CHECKED	
	BY	
	DATE	
	NO. OF SHEETS	
	NO. OF SHEETS CHECKED	
	DATE	
	BY	
	DATE	

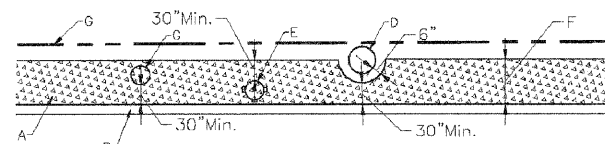

IMMOVABLE OBJECTS
(CURB-TYPE SIDEWALK, NARROW R.O.W.)

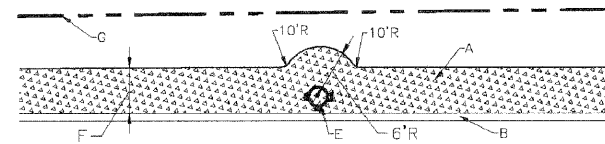

IMMOVABLE OBJECTS
(CURB-TYPE SIDEWALK, WIDE R.O.W.)

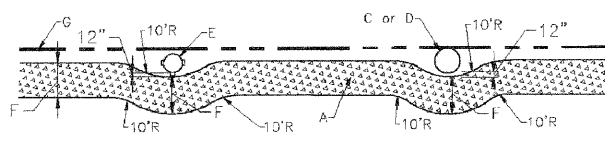

IMMOVABLE OBJECTS
(SIDEWALK WITH PARKWAY)

CONSTRUCTION NOTES

- SIDEWALK
- CURB
- SERVICE POLE, SEE NOTES 1 AND 3
- TREE TRUNK, SEE NOTE 1
- FIRE HYDRANT, SEE NOTES 1, 2, AND 3
- SIDEWALK WIDTH
- RIGHT-OF-WAY (R.O.W.)

GENERAL NOTES

- A FIRE HYDRANT, SERVICE POLE OR TREE TRUNK SHALL BE CONSIDERED IMMOVABLE ONLY WHEN DIRECTED BY THE VILLAGE.
- THE VILLAGE OF WESTMONT WATER DIVISION SHALL BE CONTACTED AS SOON AS POSSIBLE WHENEVER A FIRE HYDRANT IS FOUND TO BE IN THE PATH OF A NEW SIDEWALK, SO THAT THE FIRE HYDRANT CAN BE RELOCATED, IF POSSIBLE.
- WHEN A SERVICE POLE OR FIRE HYDRANT IS LOCATED WITHIN THE SIDEWALK AREA, AS IS CONSIDERED IMMOVABLE, A 1/2" EXPANSION JOINT SHALL BE INSTALLED ENCIRCLING THE OBJECT.

VILLAGE OF WESTMONT
STANDARD DETAIL
FOR
SIDEWALK OBSTRUCTIONS

DATE: APRIL, 2008
DWG R-12-0

ISSUED: March 1998
REVISED: April 7, 2008

I:\WMNTV\GENERAL\Standards\dwgs\SIDEWALK-OBSTSTRUCTION.dwg

CONSTRUCTION NOTES

- MAIL BOX
- MIN. 4"x4" TO MAX. 6"x6" TREATED WOOD POST OR ALTERNATE MIN. 1 1/2" TO MAX. 3" LIGHT GAUGE STEEL HOLLOW PIPE. ALSO SEE GENERAL NOTES NO. 1 AND NO. 2.
- CURB AND GUTTER
- STREET PAVEMENT
- STONE SHOULDER

GENERAL NOTES

- OTHER STRUCTURES MUST BE APPROVED BY THE VILLAGE.
- OTHER SUPPORT STRUCTURES, INCLUDING BUT NOT LIMITED TO, MASONRY COLUMNS, RAILROAD RAILS AND TIES, TRACTOR WHEELS, PLOW BLADES, MILK CANS, AND BARRELS FILLED WITH CONCRETE OR SAND, ARE EXPRESSLY FORBIDDEN.
- HOUSE NUMBERS ARE REQUIRED ON ALL MAIL BOXES. NAMES ARE OPTIONAL.
- ANY NON-CONFORMING MAILBOXES AND POSTS DAMAGED AND REQUIRING REPLACEMENT MUST FOLLOW THESE STANDARDS.

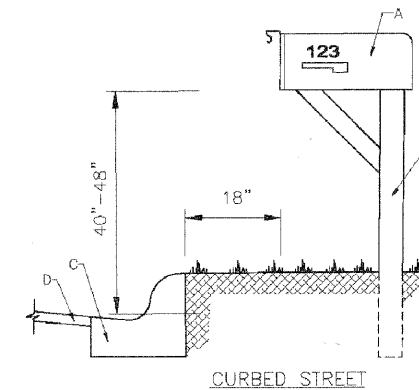

CURBED STREET

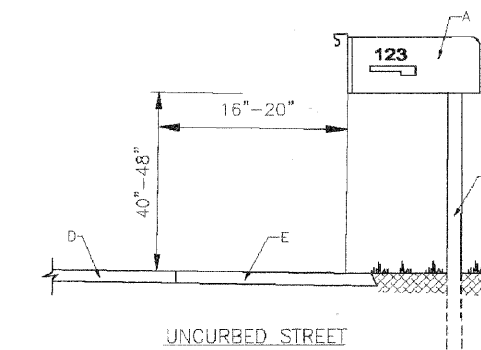

UNCURBED STREET

VILLAGE OF WESTMONT
STANDARD DETAIL
FOR
MAIL BOX SETTINGS

DATE: APRIL, 2008
DWG R-16-0

ISSUED: July 1992
REVISED: April 7, 2008

I:\WMNTV\GENERAL\Standards\dwgs\MAIL_BOX.dwg

FILE NAME =

USER NAME = #USER#

DESIGNED - JMT

REVISED -

DRAWN - JMT

REVISED -

PLOT SCALE = #SCALE#

CHECKED - JAB

REVISED -

PLOT DATE = #DATE#

DATE - 01/02/09

REVISED -

STATE OF ILLINOIS
DEPARTMENT OF TRANSPORTATION

CONSTRUCTION DETAILS

SCALE: NONE SHEET NO. 2 OF 2 SHEETS STA. TO STA.

F.A.U. RTE.	SECTION	COUNTY	TOTAL SHEETS	SHEET NO.
3003	00-00084-00-PV	DUPAGE	112	38
BLACKHAWK DR RECONSTRUCTION			CONTRACT NO. 63121	
FED. ROAD DIST. NO. 1 ILLINOIS FED. AID PROJECT				