

**BRIDGE APPROACH PAVEMENT CONNECTOR (PCC)**

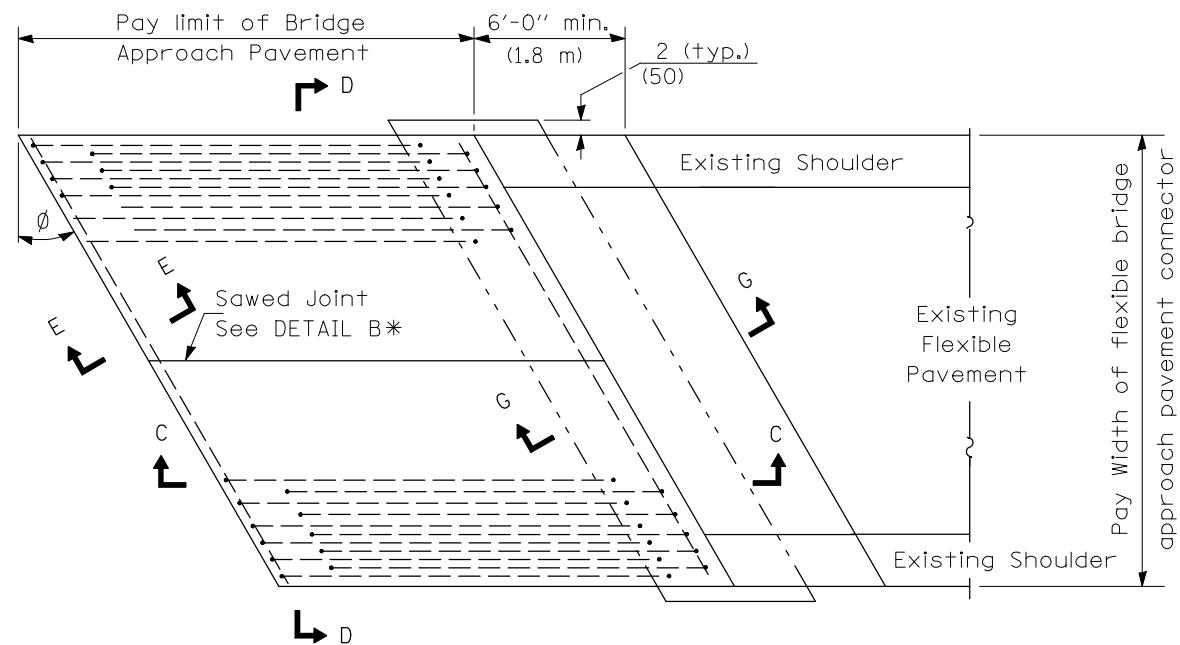

**BRIDGE APPROACH PAVEMENT CONNECTOR (FLEXIBLE)**

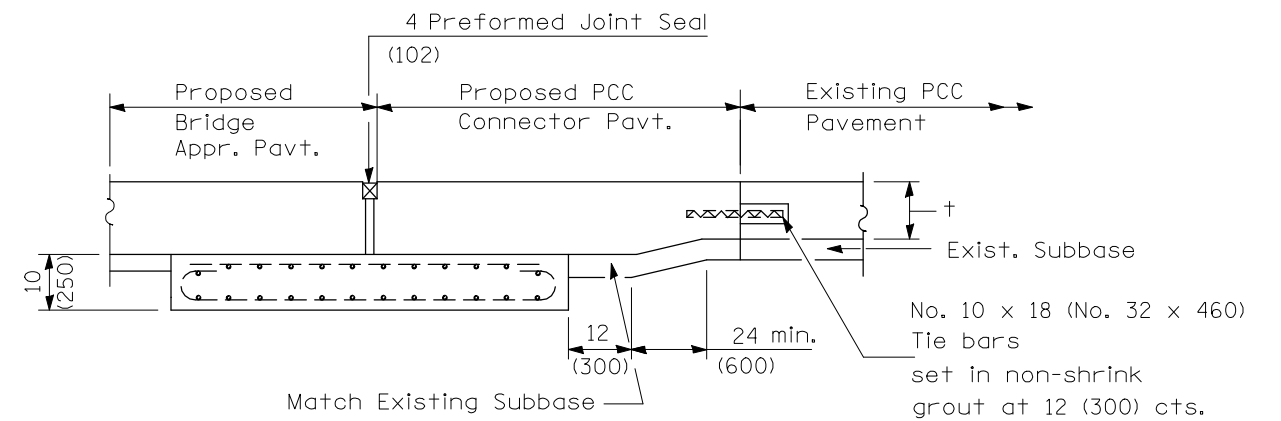

**SECTION G-G - RIGID PAVEMENT**

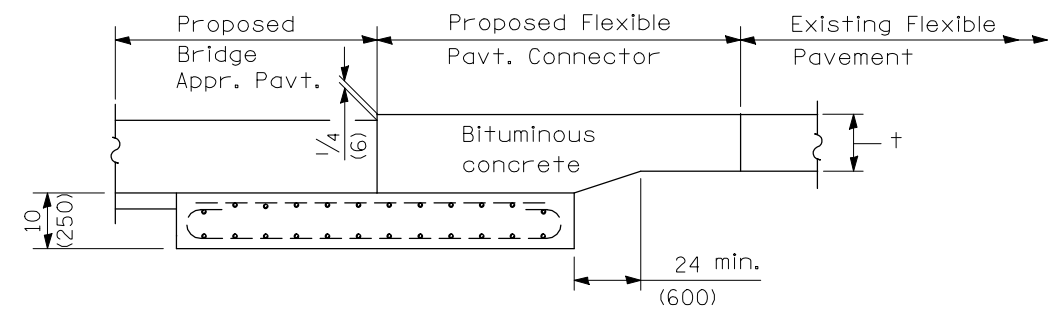

**SECTION G-G - FLEXIBLE PAVEMENT**

BRIDGE APPROACH PAVEMENT DETAIL		F.A.I. RTE.	SECTION	COUNTY	TOTAL SHEETS	SHEET NO.
SCALE:		74	(57-21B)BR	MCLEAN	61	41
SHEET NO. 2 OF 4 SHEETS		STA. TO STA.		CONTRACT NO. 70641		
ILLINOIS FED. AID PROJECT						