

EXISTING FOX ROAD TYPICAL PAVEMENT CROSS SECTION
N.T.S.

- EXISTING LEGEND**
- ① EXISTING HOT-MIX ASPHALT SURFACE (SEE TABLE)
 - ② EXISTING AGGREGATE BASE COURSE (SEE TABLE)
 - ③ EXISTING AGGREGATE SHOULDER

EXISTING THICKNESS TABLE

| APPROXIMATE STATION | HMA SURFACE THICKNESS (INCHES) | AGGREGATE BASE COURSE THICKNESS (INCHES) |
|---------------------|--------------------------------|--|
| 27+50 | 6.2 | 6 |
| 55+00 | 6.6 | - |
| 58+50 | 4.5 | - |
| 64+50 | 3.2 | 6 |

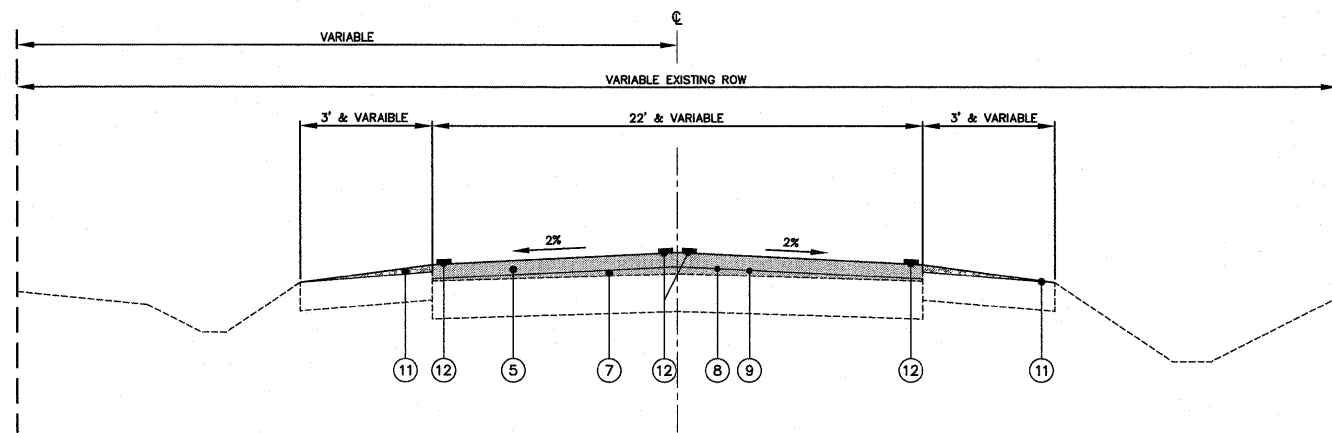

PROPOSED FOX ROAD (STA 13+80 TO STA 48+15)
TYPICAL PAVEMENT CROSS SECTION
N.T.S.

- PROPOSED LEGEND**
- ④ RESTORATION
 - ⑤ HOT-MIX ASPHALT SURFACE COURSE, MIX "D", N50, 1 1/2"
 - ⑥ LEVELING BINDER (MACHINE METHOD), N50, 1" AND VARIES (IL-9.5mm)
 - ⑦ SCARIFYING AND REGRADING EXISTING ASPHALT SURFACE
 - ⑧ BITUMINOUS MATERIALS (PRIME COAT)
 - ⑨ AGGREGATE (PRIME COAT)
 - ⑩ GRADING AND SHAPING DITCHES (AS NEEDED)
 - ⑪ AGGREGATE WEDGE SHOULDERS, TYPE B
 - ⑫ THERMOELASTIC PAVEMENT MARKING LINE, 4"

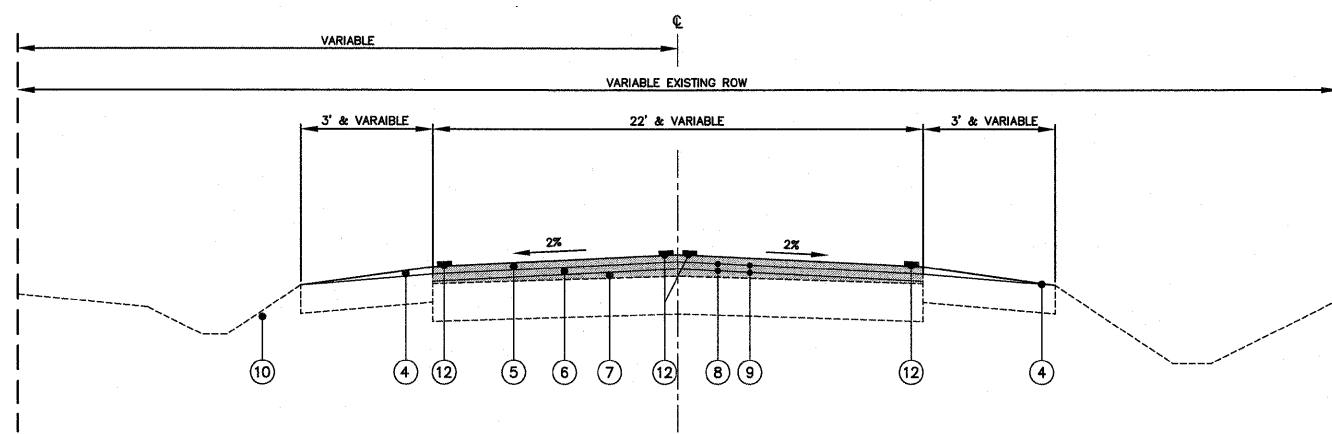

PROPOSED FOX ROAD (STA 48+15 TO STA 67+17)
TYPICAL PAVEMENT CROSS SECTION
N.T.S.

HOT-MIX ASPHALT MIXTURE REQUIREMENTS TABLE

| PAY ITEM DESCRIPTION | AC TYPE | VOIDS | MAX % RAP ALLOWABLE | DENSITY TEST METHOD |
|--|------------|----------|---------------------|--------------------------|
| HOT-MIX ASPHALT SURFACE COURSE, MIX "D", N50, 1 1/2" (IL-9.5 mm) | PG 64-22 | 4% @ N50 | 15% | CORES |
| LEVELING BINDER (MACHINE METHOD), N50, 1" AND VARIES (IL-9.5 mm) | PG 64-22 | 4% @ N50 | 25% | SATISFACTION OF ENGINEER |
| CLASS D PATCHES, TYPE II, III AND IV, 6" * | PG 64-22** | 4% @ N50 | 25% | CORES |

* CONTRACTOR SHALL USE HOT-MIX ASPHALT BINDER COURSE, IL-19.0, N50 FOR THE PATCHES.
** WHEN RAP EXCEEDS 20%, THE NEW ASPHALT BINDER IN THE MIX SHALL BE PG 58-22.
UNIT WEIGHT USED TO CALCULATE ALL HOT-MIX SURFACE MIXTURES IS 112 LBS/SY/IN

Plotted: Feb 03, 2009 @ 11:09am - Plotted By: Johnson - Tab: 04-TYP SECTN (22x34)

COPYRIGHT © 2009 ENGINEERING ENTERPRISES, INC.

Engineering Enterprises, Inc.
Consulting Engineers
52 Wheeler Road
Sugar Grove, Illinois 60554 630/466-9350

UNITED CITY OF YORKVILLE
800 GAME FARM ROAD
YORKVILLE, ILLINOIS 60560

| NO. | DATE | REVISIONS |
|-----|----------|-----------------|
| 1 | 01/28/09 | PER IDOT REVIEW |

FOX ROAD LAPP IMPROVEMENTS

TYPICAL EXISTING AND PROPOSED CROSS SECTIONS

PATH = H:\GIS\Projects\Y00815\Drawings\Y00815-Cvr.dwg