

SECTION A-A
COLLAR CONNECTION TO
PRECAST CULVERT SECTION

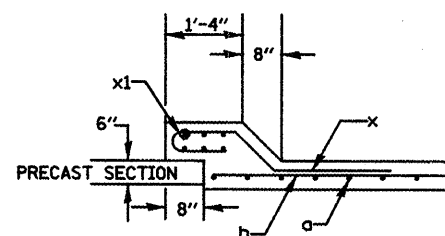

SECTION B-B
CONNECTION OF PRECAST BOX
CULVERT AND CAST-IN-PLACE COLLAR

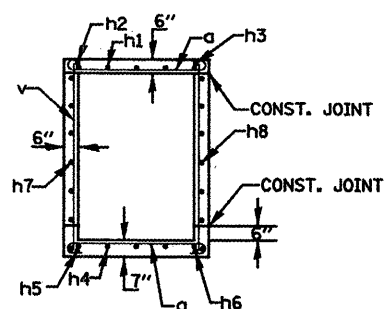

SECTION C-C
CAST-IN-PLACE
BARREL SECTION

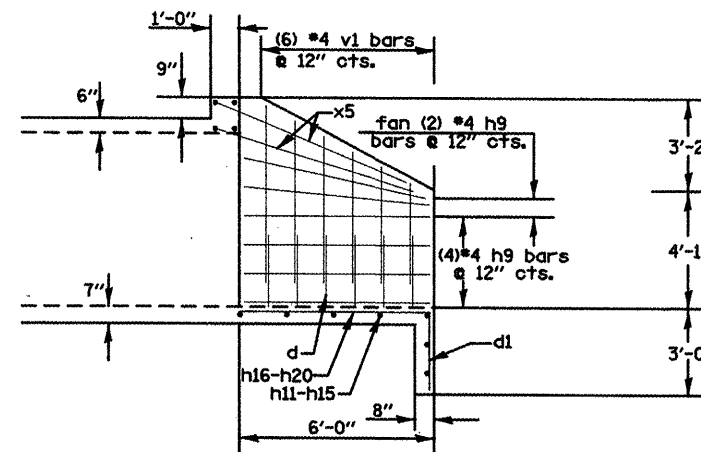

SECTION D-D
SHORT WINGWALL
OUTSIDE WALL

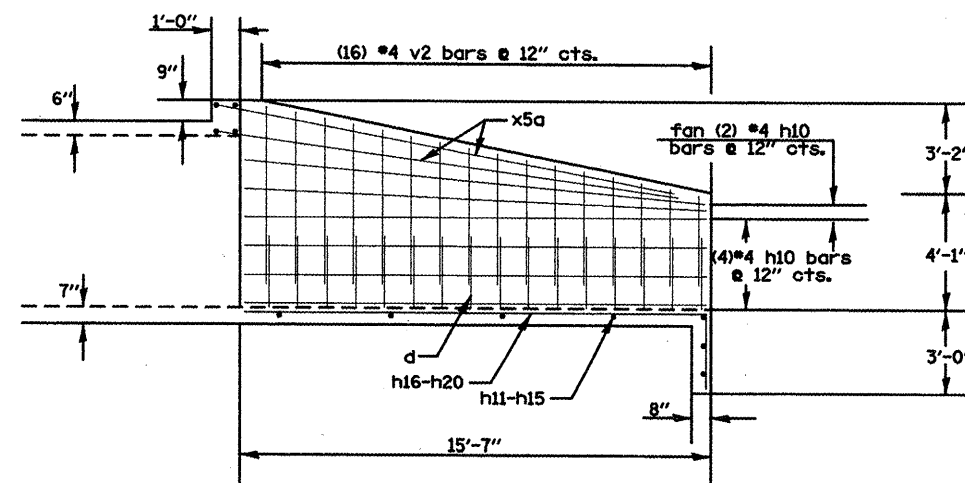

SECTION E-E
LONG WINGWALL
OUTSIDE WALL

DRAWING NOT TO SCALE

FILE NAME = d-randetail.dgn	USER NAME = ghudneam	DESIGNED -	REVISED -	STATE OF ILLINOIS DEPARTMENT OF TRANSPORTATION	STA. 98+00 4' X 6' BOX CULVERT EXTENSION DETAIL	F.A.P. RTE.	SECTION	COUNTY	TOTAL SHEETS	SHEET NO.	
		DRAWN -	REVISED -			665	036.137/W&RS-3/136R109BR-1	HENDERSON		127	
		CHECKED -	REVISED -			CONTRACT NO. 88773					
		DATE -	REVISED -			SCALE:	SHEET NO.	OF	SHEETS	STA.	TO STA.
										FED. ROAD DIST. NO. ILLINOIS FED. AID PROJECT	