

\*4 @ 9" cts. 2 bars of each length req.

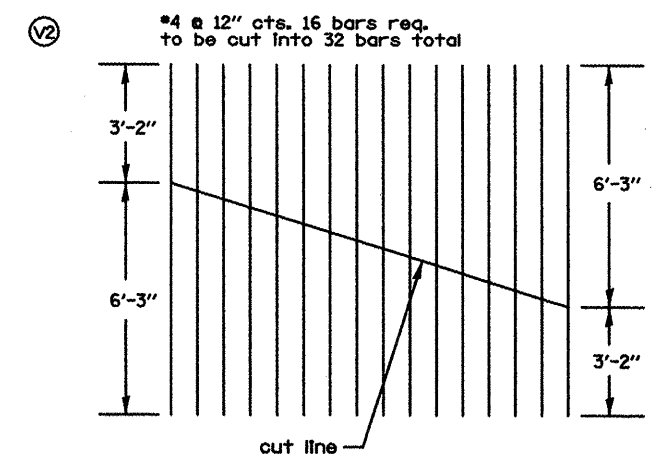
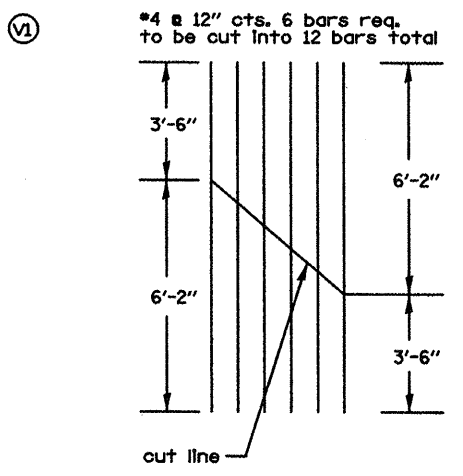
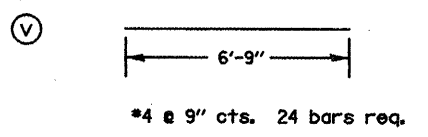
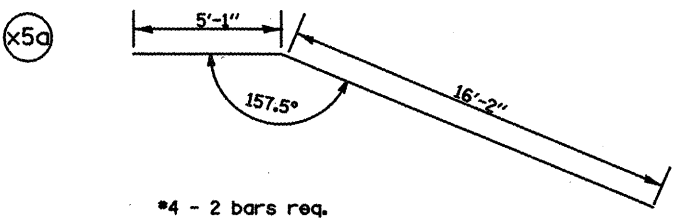
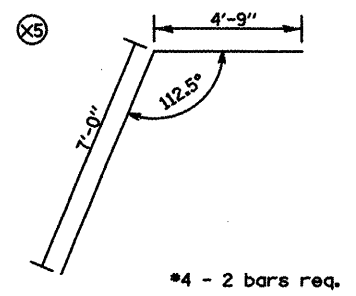
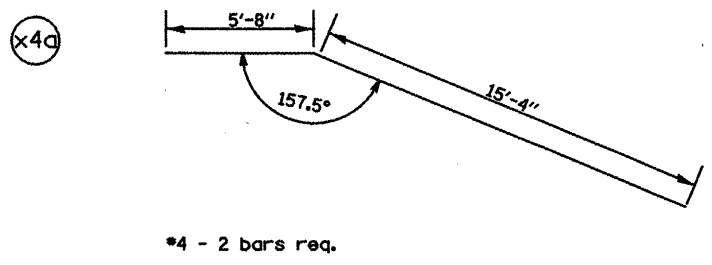
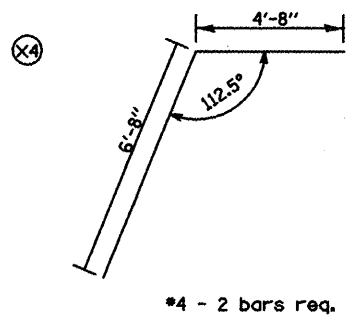
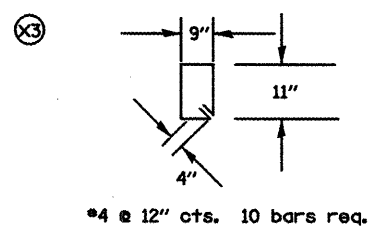
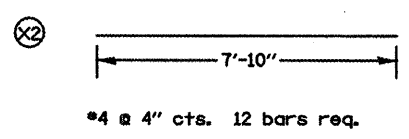
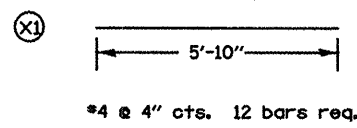
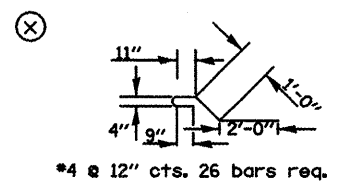

DRAWING NOT TO SCALE

FILE NAME = dr-aindetail.dgn	USER NAME = ghidneam	DESIGNED -	REVISED -	<b>STATE OF ILLINOIS DEPARTMENT OF TRANSPORTATION</b>	<b>STA. 98+00 4' X 6' BOX CULVERT EXTENSION DETAIL</b>		F.A.P. RTE. 665	SECTION 036.137(W&RS-3x136R1098R-1)	COUNTY HENDERSON	TOTAL SHEETS 129	SHEET NO. 129
	PLOT SCALE = 1/80.0000' / IN.	DRAWN -	REVISED -		SCALE:	SHEET NO. OF SHEETS	STA. TO STA.	CONTRACT NO. 88773		FED. ROAD DIST. NO.	ILLINOIS FED. AID PROJECT
	PLOT DATE = 1/28/2009	CHECKED -	REVISED -								
		DATE -	REVISED -								