

SECTION A - A

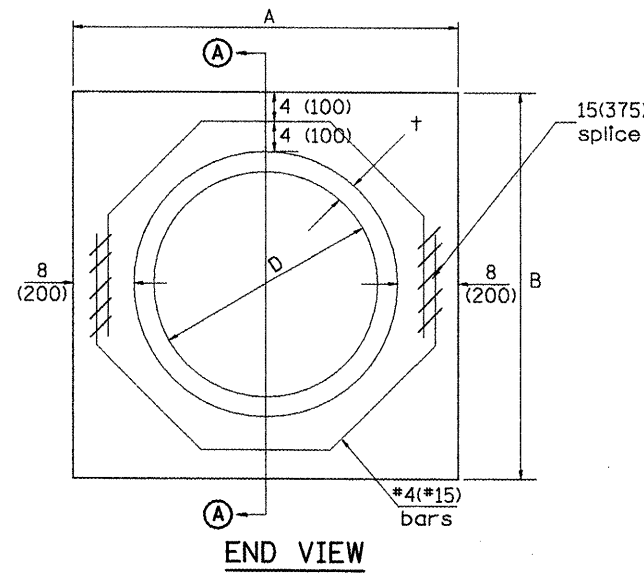

END VIEW

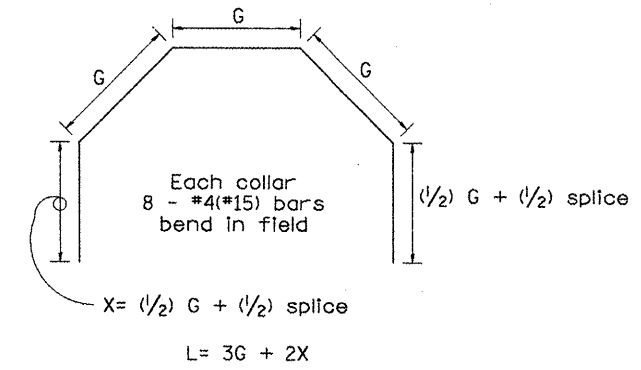

				Each Collar					
				Reinforcement Bars					
D	t	A	B	CL. SI CONC.	G	X	L	Weight	
in (mm)	in (mm)	ft (m)	ft (m)	cu. yd. (m ³)	in (mm)	in (mm)	ft (m)	lb (kg)	
12 (300)	2.00 (51)	2.67 (0.814)	2.67 (0.814)	0.4 (0.270)	9 ¹⁵ / ₁₆ (253)	12 ⁷ / ₁₆ (317)	4.57 (1.393)	24 (11)	
15 (375)	2.25 (57)	2.96 (0.902)	2.96 (0.902)	0.4 (0.315)	11 ³ / ₈ (290)	13 ³ / ₁₆ (335)	5.05 (1.541)	27 (12)	
18 (450)	2.50 (64)	3.25 (0.991)	3.25 (0.991)	0.5 (0.362)	12 ¹³ / ₁₆ (327)	13 ⁷ / ₈ (354)	5.54 (1.689)	30 (14)	
21 (525)	2.75 (70)	3.54 (1.079)	3.54 (1.079)	0.5 (0.411)	14 ¹ / ₄ (364)	14 ⁵ / ₈ (372)	6.02 (1.836)	32 (15)	
24 (600)	3.00 (76)	3.83 (1.167)	3.84 (1.167)	0.6 (0.460)	15 ¹¹ / ₁₆ (401)	15 ⁵ / ₁₆ (391)	6.51 (1.984)	35 (16)	
27 (675)	3.25 (83)	4.13 (1.259)	4.13 (1.259)	0.7 (0.516)	17 ¹ / ₄ (438)	16 ¹ / ₁₆ (409)	6.99 (2.131)	37 (17)	
30 (750)	3.50 (89)	4.42 (1.347)	4.42 (1.347)	0.7 (0.570)	18 ¹¹ / ₁₆ (475)	16 ³ / ₄ (428)	7.48 (2.279)	40 (18)	
33 (825)	3.75 (95)	4.71 (1.436)	4.71 (1.436)	0.8 (0.624)	20 ¹ / ₈ (512)	17 ¹ / ₂ (446)	7.96 (2.426)	43 (19)	
36 (900)	4.00 (102)	5.00 (1.524)	5.00 (1.524)	0.9 (0.682)	21 ⁹ / ₁₆ (549)	18 ³ / ₁₆ (465)	8.44 (2.574)	45 (20)	
42 (1050)	4.50 (114)	5.58 (1.701)	5.58 (1.701)	1.0 (.800)	24 ⁷ / ₁₆ (622)	19 ³ / ₄ (501)	9.41 (2.869)	50 (23)	
48 (1200)	5.00 (127)	6.17 (1.881)	6.17 (1.881)	1.2 (0.930)	27 ⁵ / ₁₆ (696)	21 ³ / ₁₆ (538)	10.38 (3.164)	55 (25)	

GENERAL NOTES

1. THE COLLAR SHALL BE CONSTRUCTED ENTIRELY OF CLASS SI CONCRETE IN ACCORDANCE WITH THE APPLICABLE PORTIONS OF SECTION 503 OF THE STANDARD SPECIFICATIONS. REINFORCEMENT BARS SHALL CONFORM TO SECTION 508.

QUANTITIES

CALC. BY: R. J. D. 2-2-98
 CHECKED BY: R. D. H. 2-6-98
 DATE: DATE:

QUANTITY CALCULATIONS ARE ON FILE AT THE DISTRICT 4 OFFICE, BUREAU OF PROJECT IMPLEMENTATION, DOCUMENTATION SECTION

All dimensions are in inches (millimeters) unless otherwise noted.

01-01-97	RENUM. B-8.03, NEW REVISION BOX, REVISED	T.P.	09-01-00	CORRECT WEIGHT	J.A.	STATE OF ILLINOIS DEPARTMENT OF TRANSPORTATION	PIPE CULVERT EXTENSION COLLAR (WITHOUT END SECTION)	F.A.P. RTE.	SECTION	COUNTY	TOTAL SHEETS	SHEET NO.
	TITLE BOX, ADDED QUANTITY CALCULATION BOX		10-16-06	REV. TO 2007 SPEC., CORRECT mm UNITS	M.A.			665	(136,137)W&RS-3+136R+109BR-2	HENDERSON	2/6	
04-01-97	CORRECT BAR	J.A.						CONTRACT NO. 88773				
02-10-98	REVISE QUANTITIES	J.A.						CADD STD. 542016-D4				

NOT TO SCALE

CADD STD. 542016-D4

FED. ROAD DIST. NO. ILLINOIS FED. AID PROJECT