

**DETAIL A**  
(Typical Treated Timber Splices)

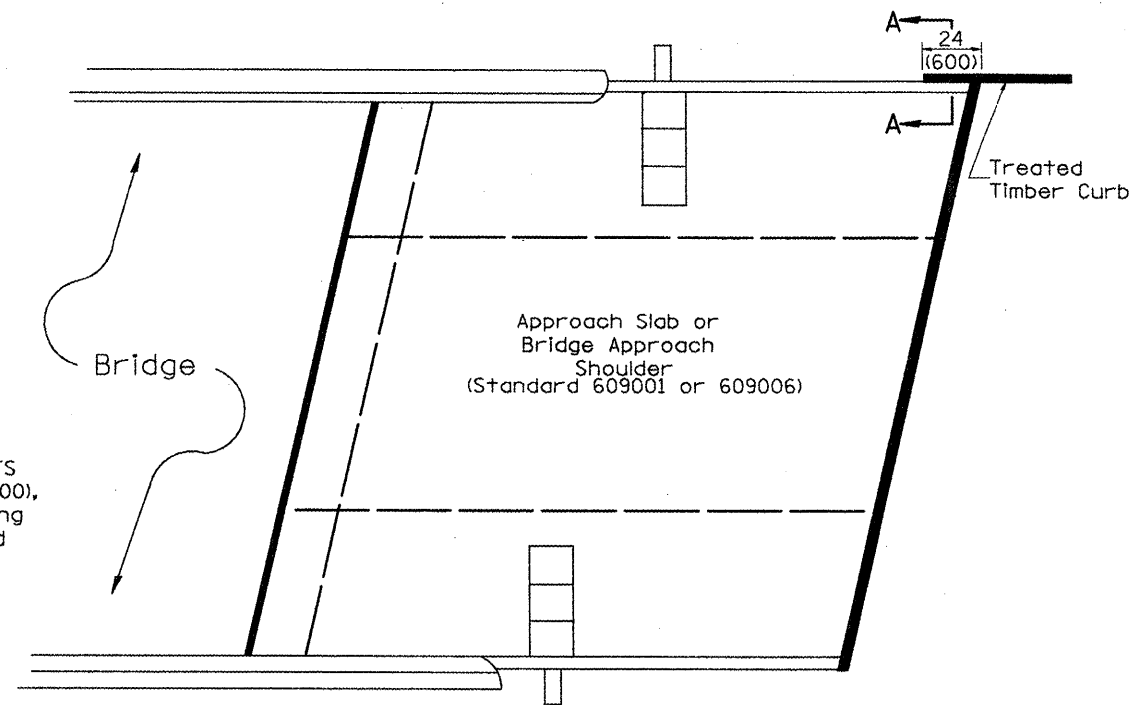

**PLAN VIEW**  
**APPROACH SLAB OR BRIDGE APPROACH SHOULDER**  
(STANDARD 609001 or 609006)

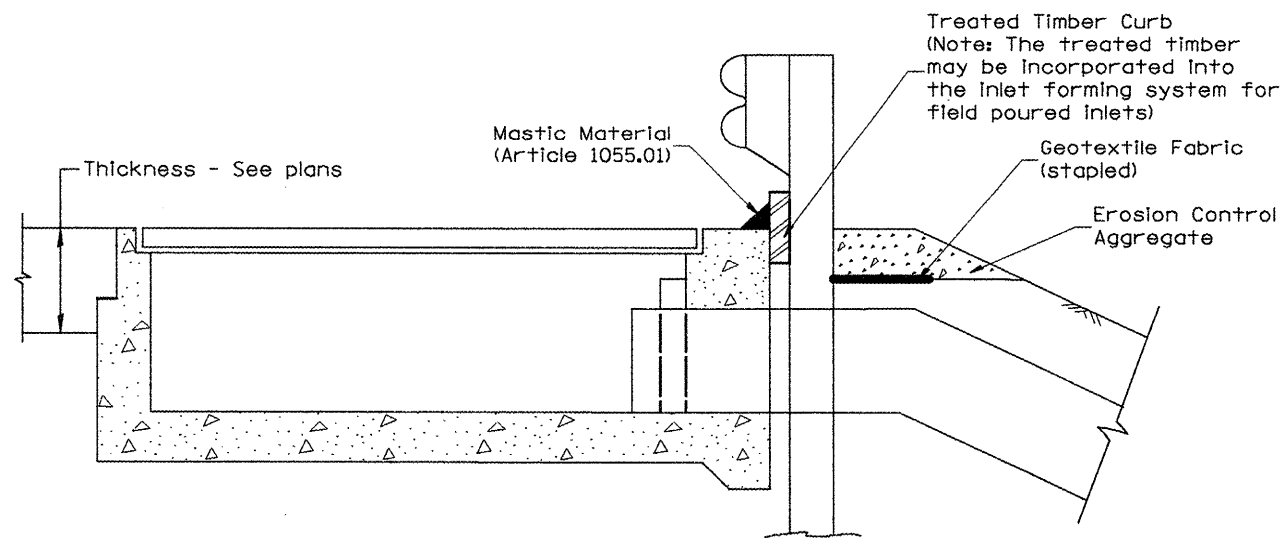

**TYPICAL SECTION WITH EROSION CONTROL CURB**  
**AT INLETS TYPE E & F (STANDARD 610001)**

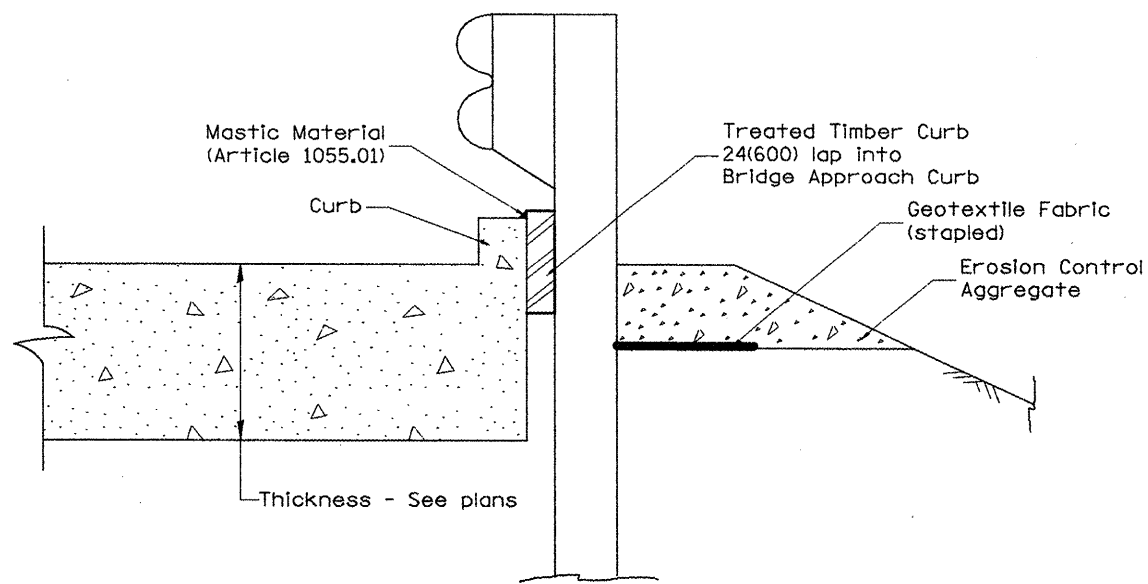

**SECTION A-A**  
**TYPICAL SECTION WITH EROSION CONTROL CURB**  
**AT BRIDGE APPROACH CURB**  
(STANDARD 609001 OR 609006)

All dimensions are in inches (millimeters) unless otherwise noted.

F.A. RTE.	SECTION	COUNTY	TOTAL SHEETS	SHEET NO.
				224
CONTRACT NO.				
FED. ROAD DIST. NO. ILLINOIS FED. AID PROJECT				