

Leave 10(250) of reinforcement exposed and place this end into concrete collar
 Location of lifting holes may vary as needed to clear reinforcement

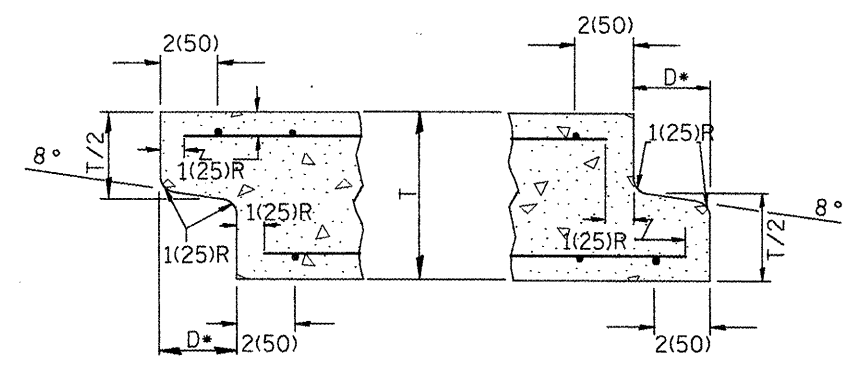

NOTE: Inlet and outlet ends shall be compatible.
 *The D dimension shall conform to the manufacturer's standards.

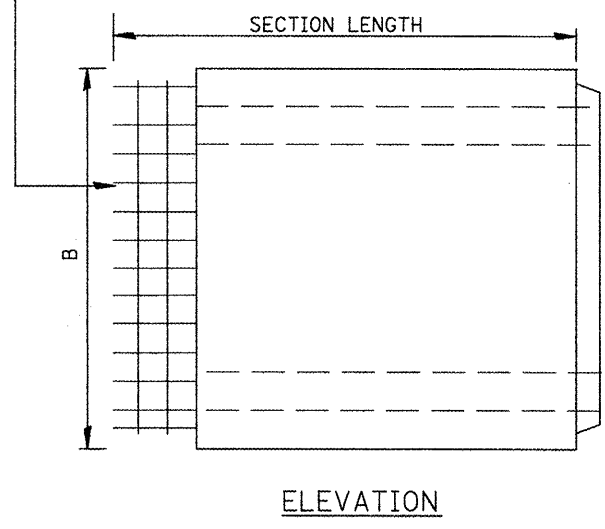
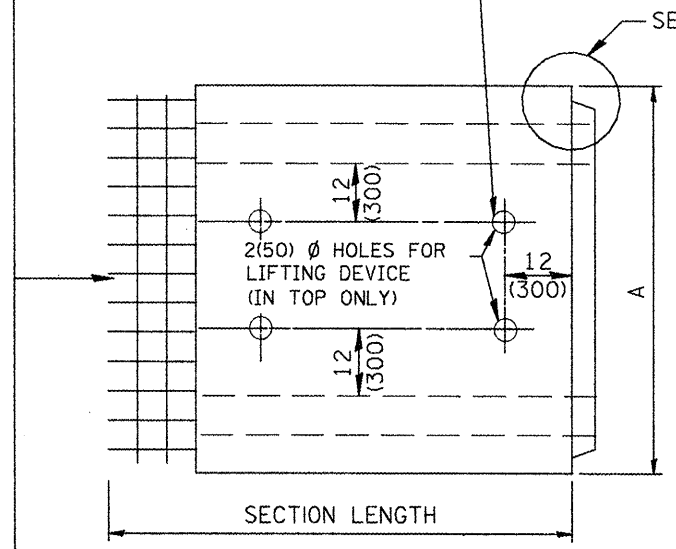
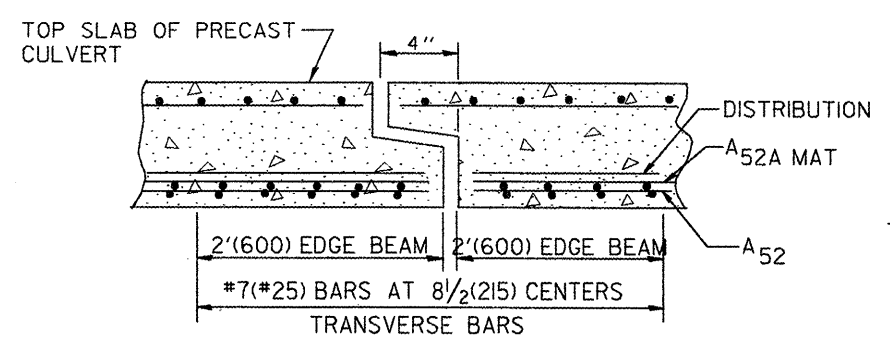

NOTE: The additional Reinforcing Steel required for edge beams shall have the same length as As2A. The required area, As10, may be combined with As2 in a single mat or placed in a separate layer as shown above. The additional Steel may be Welded Wire Fabric or grade 60 Deformed Bars.
 (See GENERAL NOTES on sheet 1 of 2)

(DIMENSIONS APPLY TO END SECTION AND BOX SECTION DETAILS)

SPAN X RISE ft (mm)	T in (mm)	A	B	C in (mm)	E in (mm)	F	G	H in (mm)	SLOPE (Y : X)
2x2 (600x600)	4(100)	32(815)	32(815)	4(100)	36(915)	36(915)	12(305)	12(305)	1 : 3
2x3 (600x900)	4(100)	32(815)	3'-8" (1.12m)	4(100)	24(610)	4'-0" (1.22m)	20(510)	16(410)	1 : 3
3x2 (900x600)	4(100)	3'-8" (1.12m)	32(815)	4(100)	36(915)	36(915)	12(305)	12(305)	1 : 3
3x2.5 (900x750)	4(100)	3'-8" (1.12m)	38(965)	4(100)	30(760)	3'-6" (1.07m)	16(410)	14(355)	1 : 3
3x3 (900x900)	4(100)	3'-8" (1.12m)	3'-8" (1.12m)	4(100)	24(610)	4'-0" (1.22m)	20(510)	16(410)	1 : 3
4x2 (1200x600)	5(125)	4'-10" (1.48m)	34(865)	5(125)	36(915)	36(915)	12(305)	12(305)	1 : 3
4x3 (1200x900)	5(125)	4'-10" (1.48m)	3'-10" (1.17m)	5(125)	24(610)	4'-0" (1.22m)	20(510)	16(410)	1 : 3
4x4 (1200x1200)	5(125)	4'-10" (1.48m)	4'-10" (1.48m)	5(125)	24(610)	4'-0" (1.22m)	24(610)	24(610)	1 : 2
4x5 (1200x1500)	5(125)	4'-10" (1.48m)	5'-10" (1.78m)	5(125)	24(610)	4'-0" (1.22m)	36(915)	24(610)	1 : 2
4x6 (1200x1800)	5(125)	4'-10" (1.48m)	6'-10" (2.09m)	5(125)	24(610)	4'-0" (1.22m)	4'-0" (1.22m)	4'-0" (1.22m)	1 : 2
5x2 (1500x600)	6(150)	6'-0" (1.83m)	36(915)	6(150)	36(915)	36(915)	12(305)	12(305)	1 : 3
5x3 (1500x900)	6(150)	6'-0" (1.83m)	4'-0" (1.22m)	6(150)	24(610)	4'-0" (1.22m)	20(510)	16(410)	1 : 3
5x4 (1500x1200)	6(150)	6'-0" (1.83m)	5'-0" (1.52m)	6(150)	24(610)	4'-0" (1.22m)	24(610)	24(610)	1 : 2
5x5 (1500x1500)	6(150)	6'-0" (1.83m)	6'-0" (1.83m)	6(150)	24(610)	4'-0" (1.22m)	36(915)	24(610)	1 : 2
6x2 (1800x600)	7(175)	7'-2" (2.17m)	38(965)	7(175)	36(915)	36(915)	12(305)	12(305)	1 : 3
6x3 (1800x900)	7(175)	7'-2" (2.17m)	4'-2" (1.27m)	7(175)	24(610)	4'-0" (1.22m)	20(510)	16(410)	1 : 3
6x4 (1800x1200)	7(175)	7'-2" (2.17m)	5'-2" (1.57m)	7(175)	24(610)	4'-0" (1.22m)	24(610)	24(610)	1 : 2
6x5 (1800x1500)	7(175)	7'-2" (2.17m)	6'-2" (1.88m)	7(175)	24(610)	4'-0" (1.22m)	36(915)	24(610)	1 : 2
6x6 (1800x1800)	7(175)	7'-2" (2.17m)	7'-2" (2.17m)	7(175)	24(610)	4'-0" (1.22m)	4'-0" (1.22m)	4'-0" (1.22m)	1 : 2
7x4 (2100x1200)	8(200)	8'-4" (2.54m)	5'-4" (1.63m)	8(200)	24(610)	4'-0" (1.22m)	24(610)	24(610)	1 : 2
7x5 (2100x1500)	8(200)	8'-4" (2.54m)	6'-4" (1.93m)	8(200)	24(610)	4'-0" (1.22m)	36(915)	24(610)	1 : 2
7x6 (2100x1800)	8(200)	8'-4" (2.54m)	7'-4" (2.24m)	8(200)	24(610)	4'-0" (1.22m)	4'-0" (1.22m)	4'-0" (1.22m)	1 : 2
7x7 (2100x2100)	8(200)	8'-4" (2.54m)	8'-4" (2.54m)	8(200)	24(610)	4'-0" (1.22m)	5'-0" (1.52m)	24(610)	1 : 2
8x4 (2400x1200)	8(200)	9'-4" (2.84m)	5'-4" (1.63m)	8(200)	24(610)	4'-0" (1.22m)	24(610)	24(610)	1 : 2
8x5 (2400x1500)	8(200)	9'-4" (2.84m)	6'-4" (1.93m)	8(200)	24(610)	4'-0" (1.22m)	36(915)	24(610)	1 : 2
8x6 (2400x1800)	8(200)	9'-4" (2.84m)	7'-4" (2.24m)	8(200)	24(610)	4'-0" (1.22m)	4'-0" (1.22m)	4'-0" (1.22m)	1 : 2
9x5 (2700x1500)	9(225)	10'-6" (3.2m)	6'-6" (1.98m)	9(225)	24(610)	4'-0" (1.22m)	36(915)	24(610)	1 : 2
9x6 (2700x1800)	9(225)	10'-6" (3.2m)	7'-6" (2.29m)	9(225)	24(610)	4'-0" (1.22m)	4'-0" (1.22m)	4'-0" (1.22m)	1 : 2