

ROUTE NO.	SECTION	COUNTY	TOTAL SHEETS	SHEET NO.
FAS 1539	*	MACON	57	26
FED. ROAD DIST. NO.		ILLINOIS	PROJECT	

00-00155-00-BR

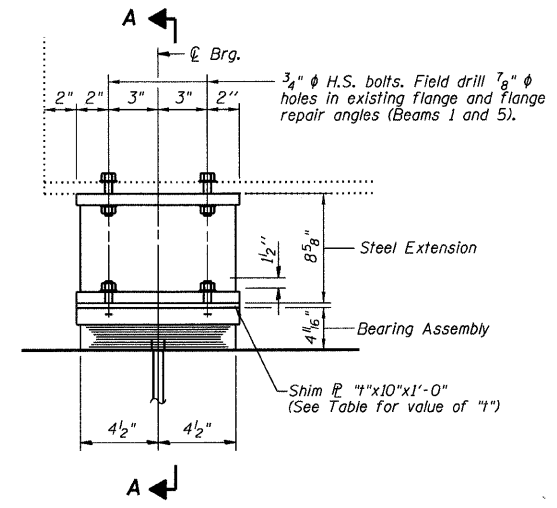

ELEVATION AT NORTH ABUTMENT

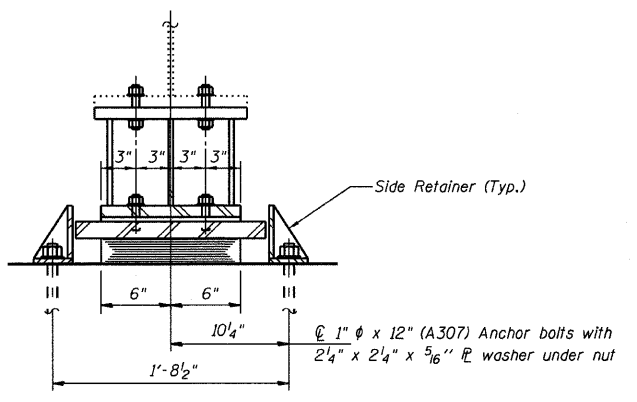

SECTION A-A

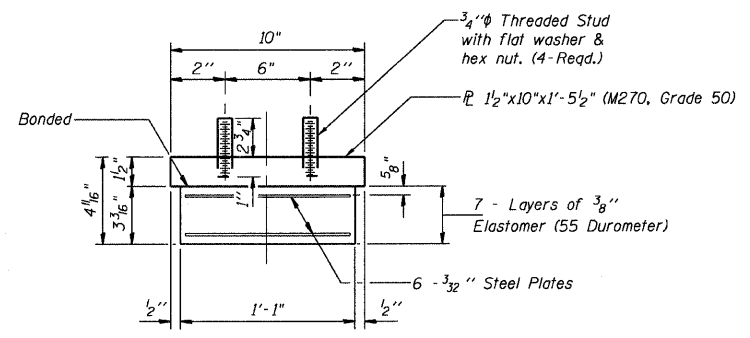

BEARING ASSEMBLY  
(At Abut 2)

Note: Shim plates shall not be placed under Bearing Assembly.

TYPE I ELASTOMERIC EXPANSION BEARING

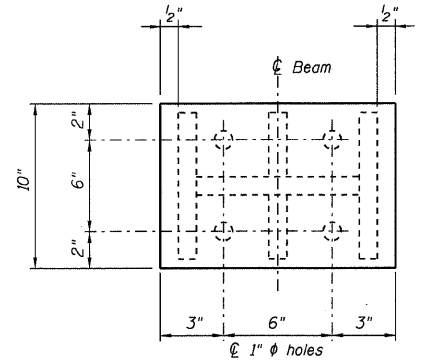

PLAN STEEL EXTENSION

TABLE OF SHIM PLATE THICKNESSES (t in inches)

	Beam 1	Beam 2	Beam 3	Beam 4	Beam 5
N Abut	5/8"	--	5/8"	3/4"	1/2"

Note: Prior to ordering any material, the Contractor shall verify in the field all bearing height and shim thickness dimensions.

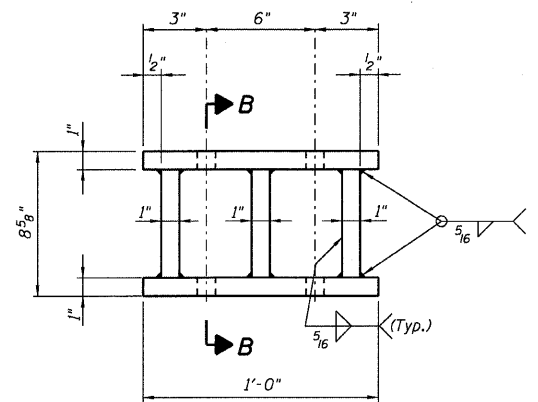

ELEVATION STEEL EXTENSION

FABRICATED STEEL EXTENSION  
(5 required)

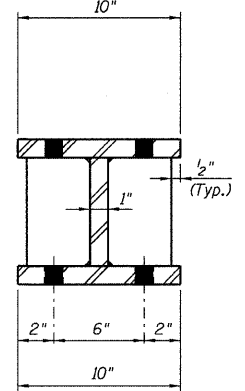

SECTION B-B

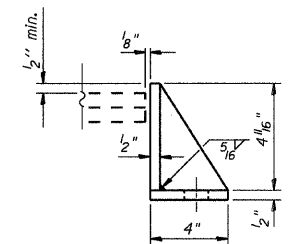

SIDE RETAINER  
(10 Req'd)

Equivalent rolled angle with stiffeners will be allowed in lieu of welded plates.

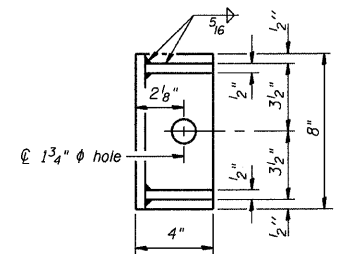

Notes:  
Anchor bolts shall be ASTM F1554 all-thread (or an Engineer-approved alternate material) of the grade(s) and diameter(s) specified, ASTM A307 Grade C anchor bolts may be used in lieu of ASTM F1554 Grade 36 (Fy=36ksi). The corresponding specified grade of AASHTO M314 anchor bolts may be used in lieu of ASTM F1554.  
Anchor bolts at fixed bearings may be either cast in place or installed in holes drilled after the supported member is in place.  
Anchor bolts for side retainers may be cast in place or installed in holes drilled before or after members are in place.  
Drilled and set anchor bolts shall be installed according to Article 521.06 of the Standard Specifications.  
Side retainers, anchor bolts and other steel members required for the bearing assembly shall be included in the cost of Elastomeric Bearing Assembly, Type I.

BILL OF MATERIAL

Item	Unit	Total
Elastomeric Bearing Assembly Type I	Each	5
Jack and Remove Existing Bearings	Each	5

NORTH ABUTMENT  
WYCKLES ROAD OVER THE SANGAMON RIVER  
ELASTOMERIC BEARING DETAILS

REVISIONS	FAS 1539	SECTION 00-00155-00-BR	DRAWN BY DATE R KING 9/08
No. DATE INITIALS	STA 30+50.00	SN 058-3030	CHECKED BY DATE JMB 9/08
1		MACON COUNTY	BOOK NUMBER 389
2			PROJECT No. 4698
3			SHEET No.
4			
5			
6			
7			
8			
9			
10			

HOMER L. CHASTAIN & ASSOCIATES, LLP  
CONSULTING ENGINEERS  
184-001277  
DECATUR CHICAGO  
(317) 422-6544 (773) 714-0050  
ROCKFORD  
(815) 489-0050