

ROUTE	SECTION	CITY	TOTAL SHEETS	SHEET NO.
FAU 8494	07-00078-00-RS	OLNEY	9	2
CONTRACT NO. 95672		ILLINOIS		

SUMMARY OF QUANTITIES			
CODE NO.	ITEM	UNIT	QUANTITY
35101400	AGGREGATE BASE COURSE, TYPE B	TON	16
40600100	BITUMINOUS MATERIALS (PRIME COAT)	GALLON	1320
40600300	AGGREGATE (PRIME COAT)	TON	28
40600635	LEVELING BINDER (MACHINE METHOD), N70	TON	875
40600982	HOT-MIX ASPHALT SURFACE REMOVAL - BUTT JOINT	SQ YD	492
40600990	TEMPORARY RAMP	SQ YD	492
40603340	HOT-MIX ASPHALT SURFACE COURSE, MIX "D", N70	TON	1110
42400100	PORTLAND CEMENT CONCRETE SIDEWALK 4 INCH	SQ FT	1751
42400800	DETECTABLE WARNINGS	SQ FT	269
44000157	HOT-MIX ASPHALT SURFACE REMOVAL, 2"	SQ YD	12935
44000500	COMBINATION CURB AND GUTTER REMOVAL	FOOT	286
44000600	SIDEWALK REMOVAL	SQ FT	1311
60255500	MANHOLES TO BE ADJUSTED	EACH	18
60266600	VALVE BOXES TO BE ADJUSTED	EACH	14
60402610	GRATES, TYPE 12	EACH	2
60404940	FRAMES AND GRATES, TYPE 23	EACH	5
60405740	FRAMES AND GRATES TO BE REMOVED	EACH	7
60604400	COMBINATION CONCRETE CURB AND GUTTER, TYPE B-6.18	FOOT	286
67100100	MOBILIZATION	L SUM	1
70102620	TRAFFIC CONTROL AND PROTECTION, STANDARD 701501	L SUM	1
70102640	TRAFFIC CONTROL AND PROTECTION, STANDARD 701801	L SUM	1
70103700	TRAFFIC CONTROL COMPLETE	L SUM	1

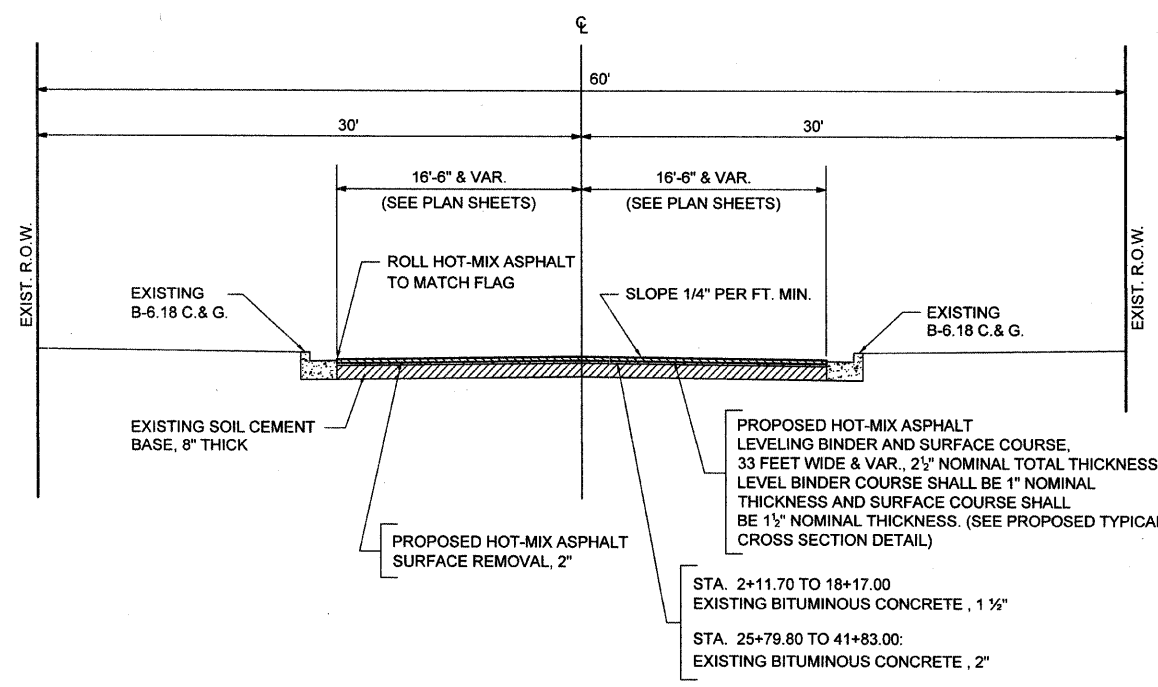

**PROPOSED TYPICAL CROSS SECTION**  
 STA. 2+11.70 TO 18+17.00  
 STA. 25+79.80 TO 41+83.00

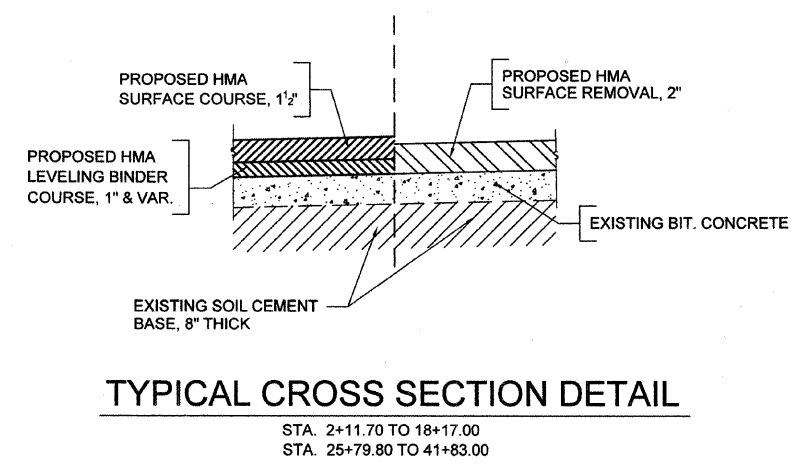

**TYPICAL CROSS SECTION DETAIL**

**GENERAL NOTES**

THIS SECTION CONSISTS OF THE CONSTRUCTION OF A 33 FOOT WIDE & VAR. HOT-MIX ASPHALT SURFACE COURSE, MIXTURE "D", N70, HOT-MIX ASPHALT LEVELING BINDER COURSE, N70, ALONG WITH EXISTING 2 INCH HOT-MIX ASPHALT SURFACE REMOVAL. CONSTRUCTION LIMITS EXTEND FROM FLAG TO FLAG OF EXISTING CURB AND GUTTER. THIS PROJECT SHOULD BE IN ACCORDANCE WITH THE PLANS, SPECIAL PROVISIONS, AND "STANDARD SPECIFICATIONS FOR ROAD AND BRIDGE CONSTRUCTION" ADOPTED JANUARY 1, 2007.

**HOT-MIX ASPHALT**

HOT-MIX ASPHALT SURFACE COURSE, MIXTURE "D" N70  
 PG GRADE: PG 70-22  
 DESIGN AIR VOIDS: 4.0% @ Ndesign 70  
 MIXTURE COMPOSITION: IL-9.5  
 FRICTION AGGREGATE: MIXTURE D

LEVELING BINDER (MACHINE METHOD) N70  
 PG GRADE: PG 70-22  
 DESIGN AIR VOIDS: 4.0% @ Ndesign 70  
 MIXTURE COMPOSITION: IL-9.5  
 FRICTION AGGREGATE: N/A

**PAVEMENT DESIGN DATA**

STA. 2+11.70 TO 18+17.00  
 ADT = 4800 CLASS II  
 P = 4535  
 SU = 225  
 MU = 40  
 URBAN MINOR ARTERIAL  
 PAVEMENT TYPE: BIT. CONC. PAVEMENT, 2 1/2"

**PAVEMENT DESIGN DATA**

STA. 25+79.80 TO 41+83.00  
 ADT = 7400 CLASS II  
 P = 6680  
 SU = 650  
 MU = 70  
 URBAN MINOR ARTERIAL  
 PAVEMENT TYPE: BIT. CONC. PAVEMENT, 2 1/2"

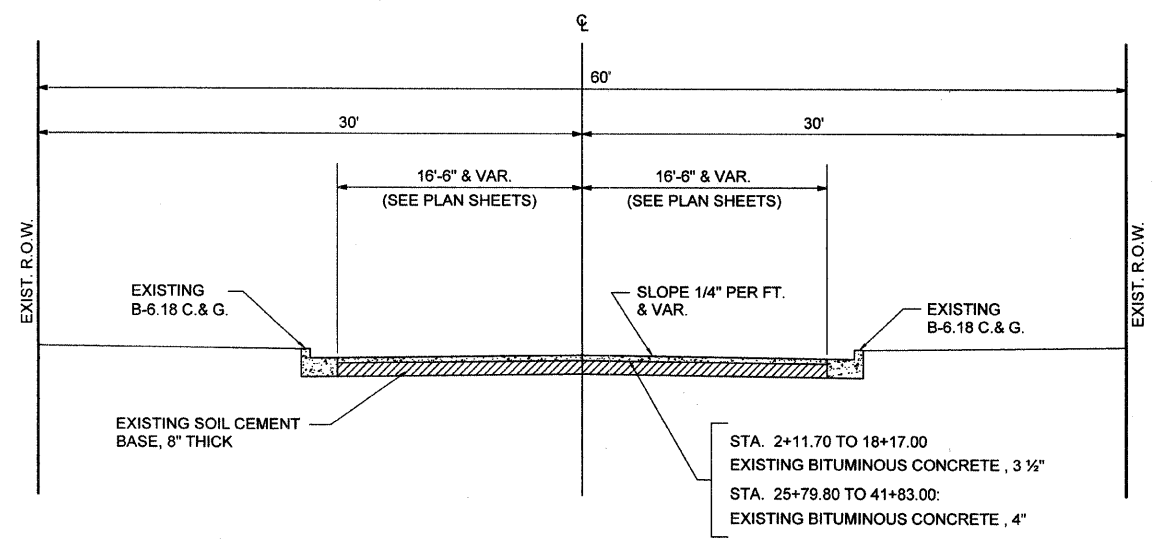

**EXISTING TYPICAL CROSS SECTION**  
 STA. 2+11.70 TO 18+17.00  
 STA. 25+79.80 TO 41+83.00

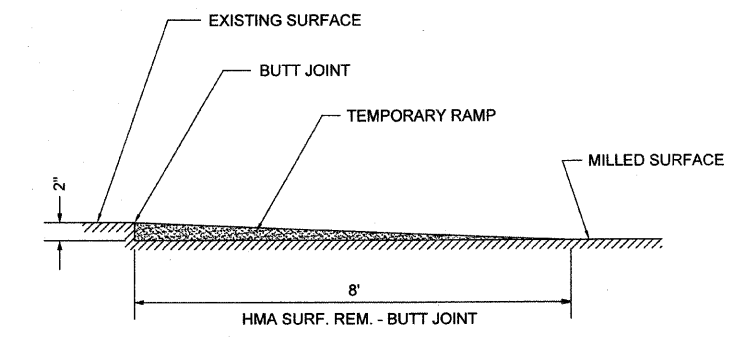

**BUTT JOINT / TEMPORARY RAMP DETAIL**

**CHARLESTON ENGINEERING, INC.**  
 CONSULTING ENGINEERS  
 105 NORTH KITCHELL  
 P.O. BOX 397  
 OLNEY, ILLINOIS 62450  
 (618) 392-0736  
 ILLINOIS DEPARTMENT OF PROFESSIONAL REGULATION REGISTRATION #184.003513