

- NOTES :
- A. DIMENSIONS SHOWN ARE MINIMUM.
  - B. TOP OF CONCRETE ENCASEMENT TO BE NOT LESS THAN 24" BELOW FINISHED SUBGRADE.
  - C. DUCT CONCRETE SHALL BE 610 STRUCTURAL P.C. CONC.
  - D. PLASTIC DUCT (PVC) SHALL BE TYPE 1 CONFORMING TO FEDERAL SPEC. W-C-1094.
  - E. ALL DUCT SHALL BE 4" INSIDE DIA.
  - F. WHERE EDGE DRAINS ARE USED, THE LENGTH OF THE DUCT SHALL BE SUCH THAT THE ENDS OF THE DUCTS WILL NOT BE LESS THAN TWO FEET FROM THE OUTSIDE EDGE OF ANY POROUS GRANULAR BACKFILL MATERIAL.
  - G. WHERE EDGE DRAINS ARE NOT USED, THE LENGTH OF THE DUCT SHALL BE SUCH THAT THE ENDS OF THE DUCTS WILL NOT BE LESS THAN THREE FEET FROM THE EDGE OF ANY PAVED SURFACE.
  - H. CABLE MARKERS SHALL BE INSTALLED AT ALL BENDS AND EVERY 200' ALONG THE HOMERUN (TURF CABLE MARKER)
  - I. USE SPLIT DUCT IN DUCT BANKS AS REQUIRED WHERE EXISTING CABLES ARE PRESENT. COST OF SPLIT DUCT TO BE INCLUDED IN THE UNIT PRICE FOR DUCT BANK.

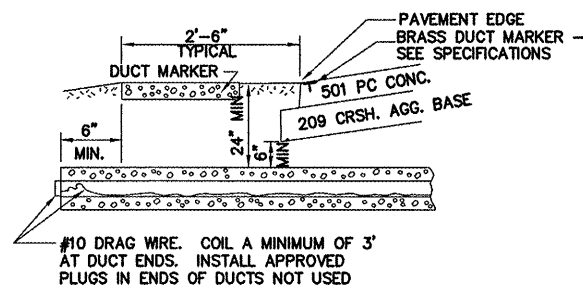

UNDERGROUND ELECTRICAL DUCT  
(NOT TO SCALE)

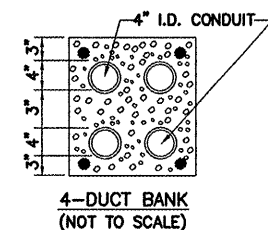
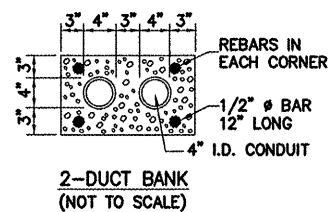
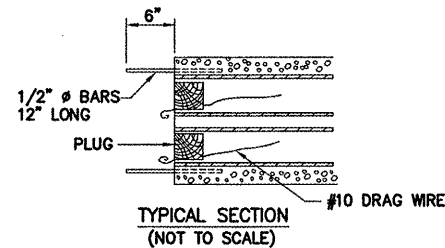
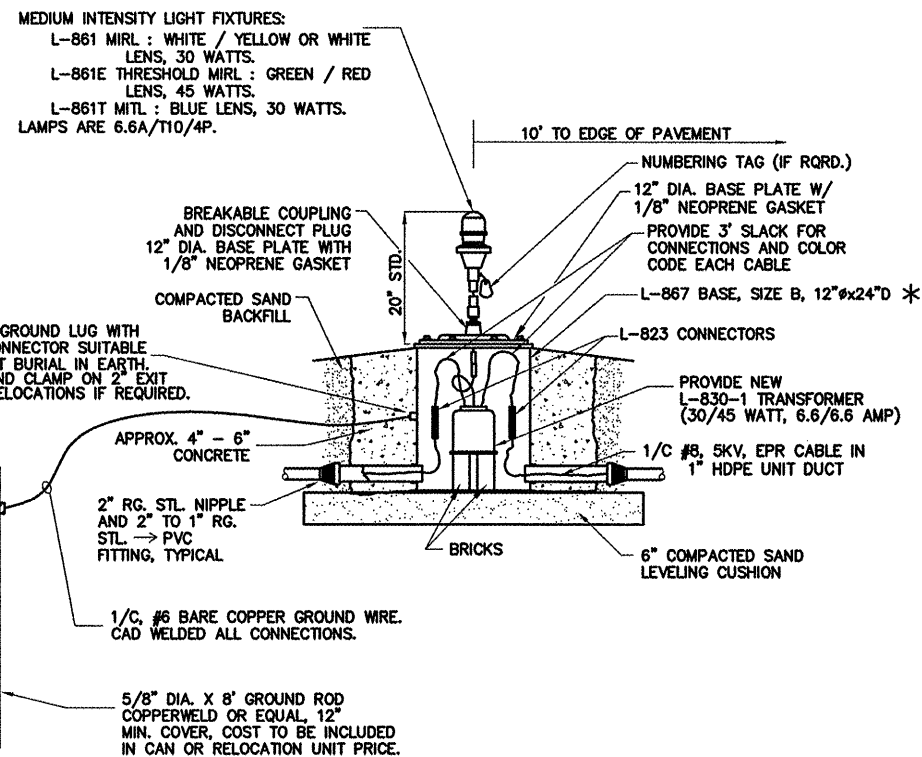

L-861 EDGE LIGHT INSTALLATION / RELOCATION DETAILS  
MEDIUM INTENSITY RUNWAY LIGHT (MIRL)  
MEDIUM INTENSITY TAXIWAY LIGHT (MITL)  
BASE MOUNTED, 6.6 AMP SERIES CIRCUIT  
NOT TO SCALE

- NOTES :
1. BREAKING GROOVE OF BREAKABLE COUPLING SHALL BE 3" TO 3 1/2" ABOVE FINISHED GRADE.
  2. \* FOR ALL NEW EDGE LIGHTS: ORDER L-867 BASE WITH ADDITIONAL 2" CONDUIT HUB APPROXIMATELY 90' FROM MAIN ENTRANCE HUB.
  3. IF THE CONDITION OF THE EXISTING LIGHTING EQUIPMENT TO BE REMOVED IS ACCEPTABLE TO THE RESIDENT ENGINEER, THE CONTRACTOR MAY REUSE THE REMOVED LIGHT FIXTURES, BASE PLATES, CANS, AND TRANSFORMERS AT THE PROPOSED LIGHT LOCATIONS. IF THE EXISTING EDGE LIGHT EQUIPMENT IS REUSED, THEN THE CONTRACTOR SHALL SUPPLY AND INSTALL 6" COMPACTED SAND LEVELING CUSHION, EXTEND THE EXISTING STEEL CONDUIT TO A POINT OUTSIDE OF THE PROPOSED CONCRETE BACKFILL, ADDITIONAL P.C. CONCRETE BACKFILL ALL AROUND (MIN. 4" THICKNESS), COMPACTED SAND BACKFILL, NEW 1/8" NEOPRENE GASKETS, RETAP BASE HOLES AS REQD., NEW STAINLESS STEEL BOLTS, NUTS, & WASHERS, AND NEW LENS & LAMPS AS REQUIRED. CONTRACTOR SHALL REPLACE ANY DAMAGED EQUIPMENT AS DIRECTED BY THE RESIDENT ENGINEER. CONTRACTOR SHALL SUPPLY AND INSTALL NEW EDGE LIGHT EQUIPMENT AS REQUIRED.
  4. SUPPLY & INSTALL NEW GROUNDING ROD WITH EACH RELOCATION PER THIS DETAIL. INCLUDE GROUNDING ROD & WIRE COSTS IN RELOCATION UNIT PRICE.

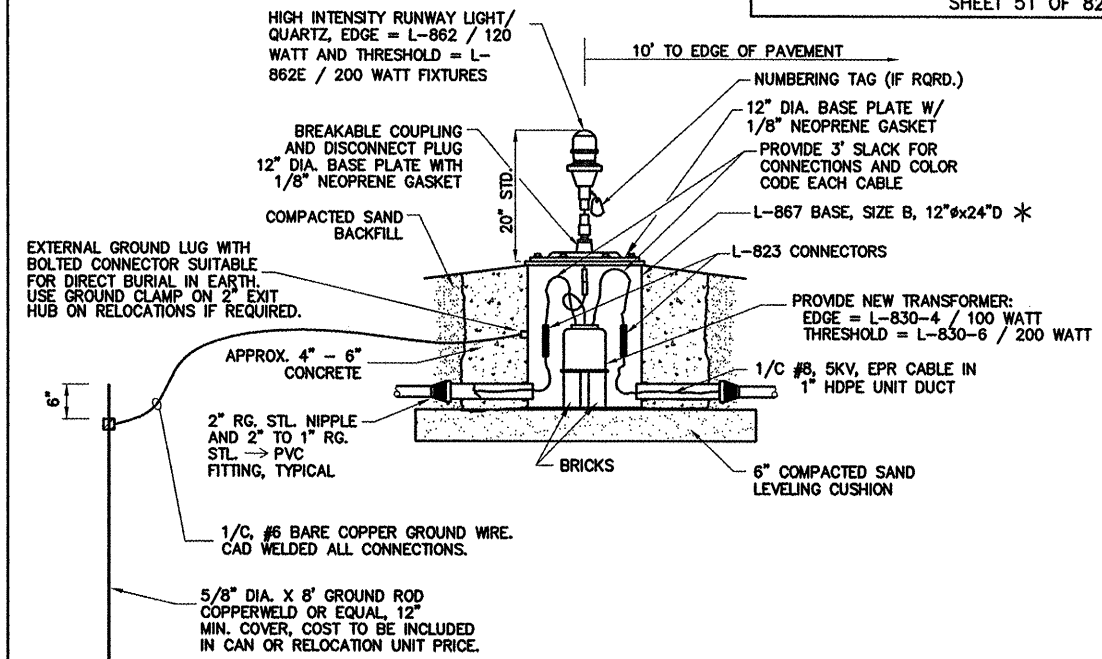

L-862 EDGE LIGHT INSTALLATION / RELOCATION DETAILS  
HIGH INTENSITY RUNWAY LIGHT / QUARTZ (HIRLQ)  
BASE MOUNTED, SERIES CIRCUIT  
NOT TO SCALE

NOTE : SEE NOTES UNDER L-861T TAXIWAY EDGE LIGHT DETAIL. THESE NOTES ALSO APPLIES TO TYPE L-862 RUNWAY EDGE LIGHTS. SUPPLY 3-WAY BASE CANS ON ALL NEW INSTALLATIONS.

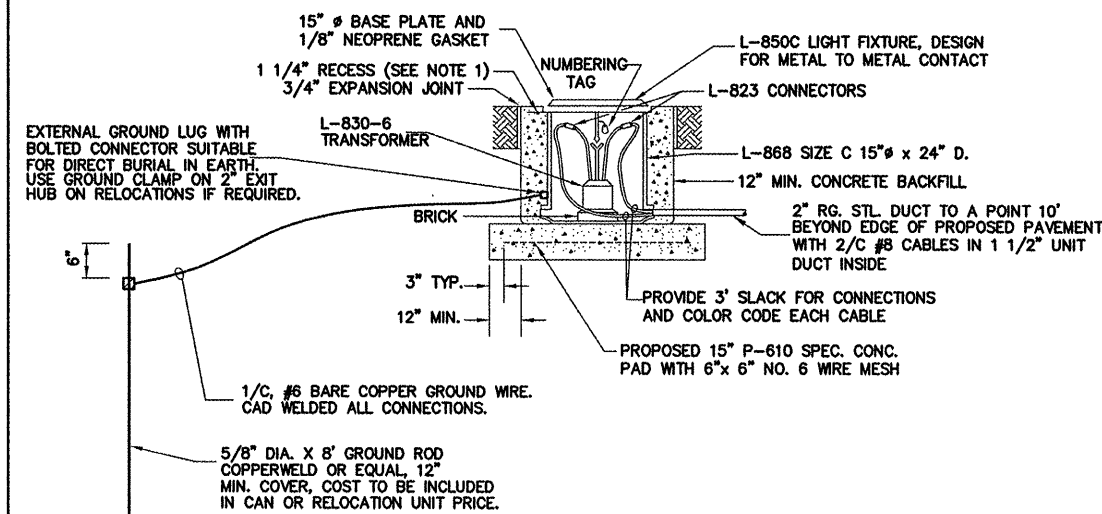

- NOTES :
1. IF INSTALLATION IS IN BITUMINOUS PAVEMENT, LEAVE CONCRETE BACKFILL 3-4 INCHES LOW FOR BACKFILL WITH BITUMINOUS MATERIAL.
  2. SEE NOTES 3 AND 4 UNDER L-861T TAXIWAY EDGE LIGHT DETAIL. THESE NOTES ALSO APPLIES TO TYPE L-850C RUNWAY EDGE LIGHTS.

TYPICAL INSTALLATION OF L-850C HIRLQ  
EDGE LIGHT IN NEW PAVEMENT  
ON L-868 BASE CAN  
NOT TO SCALE