

TYPICAL DETAIL L-861  
EDGE LIGHTS ADJUSTMENT OR RELOCATION - IN TURF

- NOTES:
1. AT THE CONTRACTOR'S OPTION, LIGHT BASE CAN EXTENSION RINGS MAY BE USED TO ADJUST LIGHT FIXTURE. CONTRACTOR TO EXTEND EXISTING CONCRETE APRON AROUND LIGHT BASE TO PROPOSED GRADE ELEVATION IF BASE CAN EXTENSION RINGS ARE USED. CONTRACTOR TO DETERMINE HEIGHT OF BASE CAN EXTENSION RINGS IN THE FIELD AT THE TIME OF CONSTRUCTION.
  2. GROUND SURFACE DRAINAGE TO FLOW AWAY FROM EDGE OF PAVEMENT AND LIGHT BASE CANS. NO WATER PONDING OR LOW SPOTS SHALL BE PERMITTED AROUND LIGHT BASE CANS.
  3. ALL EXISTING ELECTRICAL CIRCUITS TO REMAIN ACTIVE AT ALL TIMES. CONTRACTOR TO PROVIDE, INSTALL, AND MAINTAIN TEMPORARY ABOVE GROUND JUMPER CABLES AS REQUIRED TO PROVIDE CIRCUIT CONTINUITY IN ALL CIRCUITS AT ALL TIMES DURING CONSTRUCTION. COSTS TO BE INCLUDED IN THE LIGHTING CONTRACT UNIT PRICES. LENGTH OF JUMPER CABLES SHALL NOT BE MEASURED FOR PAYMENT AND / OR PAID FOR.
  4. SUPPLY & INSTALL NEW GROUNDING ROD WITH EACH ADJUSTMENT / RELOCATION PER THIS DETAIL. INCLUDE GROUNDING ROD & WIRE COSTS IN ADJUSTMENT / RELOCATION UNIT PRICE.

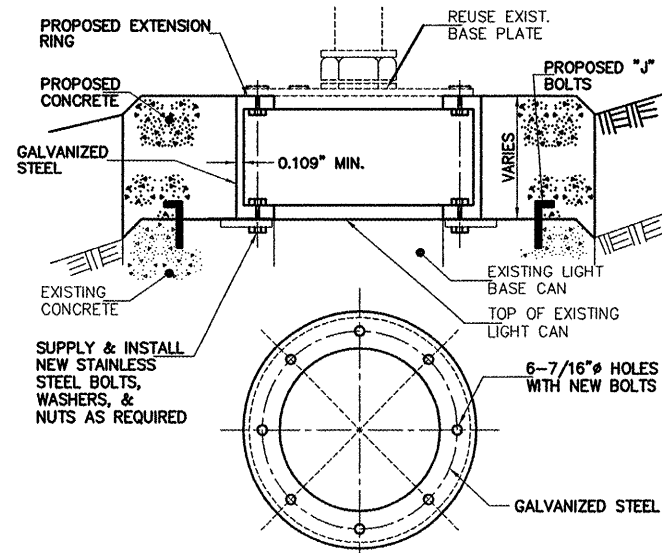

NOTE: THE CONTRACTOR SHALL FIELD VERIFY EXISTING LIGHT BASE TYPES (MOST ARE 12" L-867) AND REQUIRED HEIGHT ADJUSTMENT DIMENSIONS. NO ADDITIONAL PAYMENT WILL BE MADE FOR ALTERNATE LIGHT CAN TYPES. REDRILL AND RETAP EXISTING HOLES AS REQUIRED. COSTS SHALL BE INCLUDED IN THE UNIT PRICE FOR LIGHT ADJUSTMENT.

OPTIONAL EXTENSION RING DETAIL  
N.T.S.

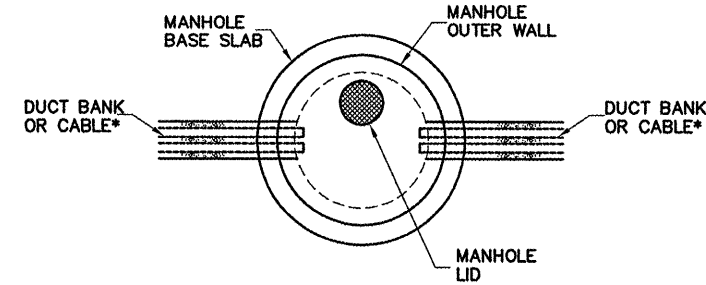

PLAN VIEW

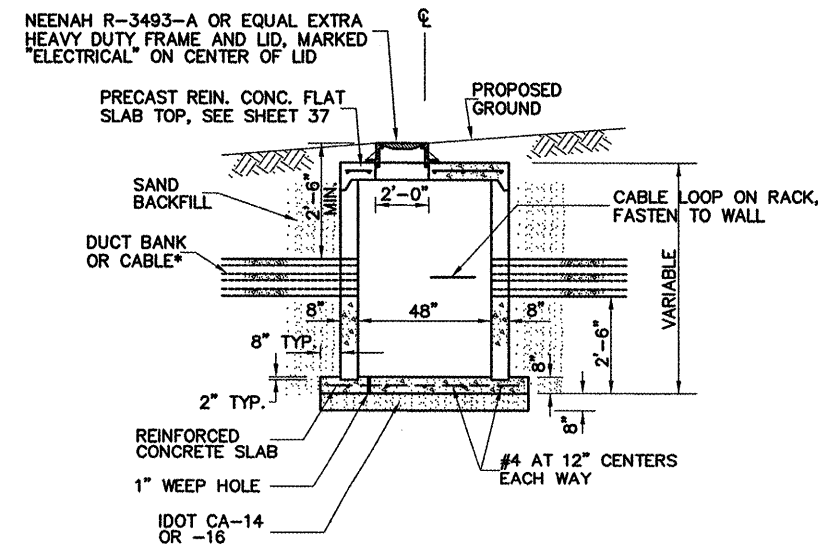

\* = FOR CABLE: INSTALL 2" RG. STL. CONDUIT SLEEVES THROUGH MANHOLE WALL. INSTALL WATERPROOF BUSHINGS ON ENDS OF CONDUITS.

FURNISHING AND INSTALLING SAND CUSHION, CONCR. BASE SLAB, SAND BACKFILL, FRAME & LID, CABLE RACK AND FLAT SLAB TOP TO BE INCLUDED IN THE CONTRACT UNIT PRICE .

PROFILE VIEW

DETAIL OF ELECTRICAL MANHOLE  
ITEM AT110710