

143

STATE OF ILLINOIS  
DEPARTMENT OF TRANSPORTATION

F.A.P. ROUTE	SECTION	COUNTY	TOTAL SHEETS	SHEET NO.
322A	(46,47)RS-3 (58-20-1)RS-1	MACON	24	1
		ILLINOIS	CONTRACT NO. 74779	

FOR INDEX OF SHEETS, SEE SHEET NO. 2

STA EQN: STA. 467+30.96 (BK) = 1480+00 (AH)

ADT = 9,300 (US 51)  
11% TRUCKS

# PROPOSED HIGHWAY PLANS

F.A.P. ROUTE 322A (US 51)  
SECTION (46,47)RS-3, (58-20-1)RS-1  
PROJECT NHPP-4AQ0(441)  
RESURFACING  
MACON COUNTY

C-97-003-17



END PROJECT  
STA. 1716+44



BEGIN PROJECT  
STA. 212+84

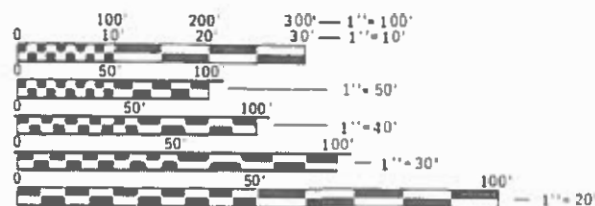

FULL SIZE PLANS HAVE BEEN PREPARED USING STANDARD ENGINEERING SCALES. REDUCED SIZED PLANS WILL NOT CONFORM TO STANDARD SCALES. IN MAKING MEASUREMENTS ON REDUCED PLANS, THE ABOVE SCALES MAY BE USED.

J.U.L.I.E.  
JOINT UTILITY LOCATION INFORMATION FOR EXCAVATION  
1-800-892-0123  
OR 811

PROJECT ENGINEER: TOM RONAN  
PROJECT MANAGER: EDWIN TIPSWORD  
PHONE: (217) 342-8314  
CONTRACT NO. 74779

GROSS LENGTH = 49,091 FT. = 9.30 MILE  
NET LENGTH = 46,991 FT. = 8.90 MILE

STATE OF ILLINOIS  
DEPARTMENT OF TRANSPORTATION

SUBMITTED January 29 20 20  
Jeffrey P. Myerka REGIONAL ENGINEER

March 20 20 20  
March 20 20 20  
ENGINEER OF DESIGN AND ENVIRONMENT

March 20 20 20  
James J. Ginn 13  
DIRECTOR OF HIGHWAYS PROJECT IMPLEMENTATION

PRINTED BY THE AUTHORITY  
OF THE STATE OF ILLINOIS

## INDEX OF SHEETS

SHEET NO.	ITEM
1	COVER SHEET
2	INDEX OF SHEETS, GENERAL NOTES & HIGHWAY STANDARDS
3-9	SUMMARY OF QUANTITIES
10-12	TYPICAL SECTIONS
13-30	SCHEDULE OF QUANTITIES
31-32	STAGING TYPICAL CROSS SECTIONS
33-50	PLAN SHEETS
51-54	CONSTRUCTION DETAILS
55	STRUCTURE LOCATION MAP
56-58	STAGED TRAFFIC CONTROL
59-74	STRUCTURE PLANS
75-76	STRIPING DETAILS
77-80	TYPICAL APPLICATIONS OF PAVEMENT MARKING AND RAISED REFLECTIVE PAVEMENT MARKERS
81-82	TYPICAL APPLICATIONS OF INTERSTATE PAVEMENT MARKING
83-84	DETOUR SIGNING

THE FOLLOWING STANDARDS ARE A PART OF THESE PLANS AND ARE INCLUDED FOLLOWING THE LAST NUMBERED SHEET OF THE PLANS.

STD. NO.	DESCRIPTION
000001-07	STANDARD SYMBOLS, ABBREVIATIONS, AND PATTERNS
001006	DECIMAL OF AN INCH AND OF A FOOT
406001-06	ENTRANCE RAMP TERMINAL
406101-05	EXIT RAMP TERMINAL
442201-03	CLASS C AND D PATCHES
482001-02	HMA SHOULDER ADJACENT TO FLEXIBLE PAVEMENT
606301-04	PC CONCRETE ISLANDS AND MEDIANS
630001-12	STEEL PLATE BEAM GUARDRAIL
630301-09	SHOULDER WIDENING FOR TYPE I (SPECIAL) GUARDRAIL TERMINALS
631011-10	TRAFFIC BARRIER TERMINAL, TYPE 2
642001-02	SHOULDER RUMBLE STRIPS 16"
701101-05	OFF-RD OPERATIONS, MULTILANE, 15' TO 24" FROM PAVEMENT EDGE
701106-02	OFF-RD MOVING OPERATIONS, MULTILANE, MORE THAN 15' AWAY
701321-18	LANE CLOSURE, 2L, 2W, BRIDGE REPAIR WITH BARRIER
701400-09	APPROACH TO LANE CLOSURE, FREEWAY/EXPRESSWAY
701401-12	LANE CLOSURE, FREEWAY/EXPRESSWAY
701406-12	LANE CLOSURE, FREEWAY/EXPRESSWAY, DAY OPERATIONS ONLY
701411-09	LANE CLOSURE, MULTILANE, AT ENTRANCE OR EXIT RAMP, FOR SPEEDS >= 45 MPH
701426-09	LANE CLOSURE, MULTILANE, INTERMITTENT OR MOVING OPERATION, FOR SPEEDS >= 45 MPH
701451-05	RAMP CLOSURE FREEWAY/EXPRESSWAY
701456-05	PARTIAL EXIT RAMP CLOSURE, FREEWAY/EXPRESSWAY
701901-08	TRAFFIC CONTROL DEVICES
725001-01	OBJECT AND TERMINAL MARKERS
781001-04	TYPICAL APPLICATIONS RAISED REFLECTIVE PAVEMENT MARKERS
782006-01	GUARDRAIL AND BARRIER WALL REFLECTOR MOUNTING DETAILS
B.L.R. 21-9	TYPICAL APPLICATION OF TRAFFIC CONTROL DEVICES FOR CONSTRUCTION ON RURAL LOCAL HIGHWAYS

## GENERAL NOTES

THE MATERIAL USED FOR AGGREGATE WEDGE SHOULDERS, TYPE B SHALL BE CRUSHED STONE, CRUSHED CONCRETE OR RAP. WHEN APPLYING SHORT TERM PAVEMENT MARKINGS, TEMPORARY TAPE SHALL BE USED ON THE SURFACE COURSE AND PAINT SHALL BE USED ON MILLED SURFACES.

THE FOLLOWING MIXTURE REQUIREMENTS ARE APPLICABLE FOR THIS PROJECT:

APPLICATION	AC/PG	DESIGN AIR VOIDS	MIXTURE COMPOSITION	FRICTION AGGREGATE	QUALITY MANAGEMENT
POLYMERIZED HMA SURFACE COURSE, STONE MATRIX ASPHALT, 12.5, MIX "E", N80 (2")	SBS 76-22	4.0% @ N=80	IL - 12.5	MIXTURE E	PFP
POLYMERIZED HOT MIX ASPHALT BINDER COURSE, IL-9.5FG, N90 (1 3/4")	SBS 70-22	4.0% @ N=90	IL - 9.5FG	N/A	PFP
HMA PATCHING, CLASS "D"	PG 64-22	4.0% @ N=90	IL 19.0	N/A	QC/QA
INCIDENTAL HOT-MIX ASPHALT SURFACING	PG 64-22	4.0% @ N=70	IL - 9.5	C	QC/QA
HMA SHOULDERS, (TOP LIFT)	PG 64-22	4.0% @ N=70	IL - 9.5	C	QC/QA
HMA SHOULDERS, (BOTTOM LIFTS)	PG 64-22	4.0% @ N=70	IL 19.0	N/A	QC/QA
PARTIAL DEPTH PAVEMENT PATCHING	PG 64-22	4.0% @ N=90	IL 19.0	N/A	QC/QA

THE FOLLOWING RATES OF APPLICATION HAVE BEEN USED IN THE CALCULATING PLAN QUANTITIES:

AGGREGATE SHOULDERS	2.05 TONS/CU YD
STONE MATRIX HOT-MIX ASPHALT	130 LBS/SQ YD/INCH
HOT-MIX ASPHALT (OTHER THAN SMA)	112 LBS/SQ YD/INCH

FILE NAME =	USER NAME = steffenmk	DESIGNED -	REVISED -	<b>STATE OF ILLINOIS DEPARTMENT OF TRANSPORTATION</b>	<b>INDEX OF SHEETS, HIGHWAY STANDARDS &amp; GENERAL NOTES</b>	F.A.P. RTE.	SECTION	COUNTY	TOTAL SHEETS	SHEET NO.	
pww\planroom.dot\illinois.gov\PWIDOT\Documents\DOT Offices\District 7\Projects\74779\CADDData\CADsheets\DRAWN-shl-gennote.dgn		CHECKED -	REVISED -			322A	(46,47)RS-3, (58,20.1)RS-1	MACON	84	2	
PLOT SCALE = 100.0000 ' / in.		DATE -	REVISED -			CONTRACT NO. 74779					
Default	PLOT DATE = 1/29/2020					SCALE: N/A	SHEET 1 OF 1 SHEETS	STA.	TO STA.	ILLINOIS FED. AID PROJECT	



ILLINOIS DEPARTMENT OF TRANSPORTATION			TOTAL QUANTITIES				
CODE NO	ITEM	UNIT		0005	0047 S.N. 058-0122	0047 S.N. 058-0123	0047 S.N. 058-0124
44000164	HOT-MIX ASPHALT SURFACE REMOVAL, 3 3/4"	SQ YD	1414	1414			
44000182	HOT-MIX ASPHALT SURFACE REMOVAL, 8"	SQ YD	28619	28619			
44004250	PAVED SHOULDER REMOVAL	SQ YD	37837	37837			
44050217	LONGITUDINAL PARTIAL DEPTH REMOVAL 5"	FOOT	187180	187180			
44201835	CLASS D PATCHES, TYPE I, 16 INCH	SQ YD	9	9			
44201839	CLASS D PATCHES, TYPE II, 16 INCH	SQ YD	50	50			
44201843	CLASS D PATCHES, TYPE III, 16 INCH	SQ YD	252	252			
44201845	CLASS D PATCHES, TYPE IV, 16 INCH	SQ YD	547	547			
44209000	LONGITUDINAL PARTIAL DEPTH PATCHING	TON	11647	11647			
48102100	AGGREGATE WEDGE SHOULDER, TYPE B	TON	2079	2079			
48203022	HOT-MIX ASPHALT SHOULDERS, 6 1/4"	SQ YD	38961	38961			
48203029	HOT-MIX ASPHALT SHOULDERS, 8"	SQ YD	28623	28623			
50102400	CONCRETE REMOVAL	CU YD	12.5		7.3	5.2	
50300255	CONCRETE SUPERSTRUCTURE	CU YD	12.5		7.3	5.2	

MODEL: Default  
 FILE: Model: 322A (46,47)RS-3, (58-20-1)RS-1  
 PROJECT: 74779 CAD Data CAD Sheets 074779-ht-500.dgn

USER NAME = steffemk	DESIGNED -	REVISED -
PLOT SCALE = 100.0000' / in.	DRAWN -	REVISIED -
PLOT DATE = 1/29/2020	CHECKED -	REVISIED -
	DATE -	REVISIED -

**STATE OF ILLINOIS  
DEPARTMENT OF TRANSPORTATION**

**SUMMARY OF QUANTITIES**

SCALE: SHEET OF SHEETS STA. TO STA.

F.A.P. RTE.	SECTION	COUNTY	TOTAL SHEETS	SHEET NO.
322A	(46,47)RS-3, (58-20-1)RS-1	MACON	84	4
CONTRACT NO. 74779				
ILLINOIS FED. AID PROJECT				

ILLINOIS DEPARTMENT OF TRANSPORTATION			TOTAL QUANTITIES	80% FED 20% STATE			
CODE NO	ITEM	UNIT		0005	0047 S.N. 058-0122	0047 S.N. 058-0123	0047 S.N. 058-0124
50800205	REINFORCEMENT BARS, EPOXY COATED	POUND	3080		1700		1380
50800515	BAR SPLICERS	EACH	16				16
50800530	MECHANICAL SPLICERS	EACH	20		20		
52000110	PREFORMED JOINT STRIP SEAL	FOOT	203		110		93
* 63000001	STEEL PLATE BEAM GUARDRAIL, TYPE A, 6 FOOT POSTS	FOOT	412.5	412.5			
* 63100045	TRAFFIC BARRIER TERMINAL, TYPE 2	EACH	2	2			
* 63100167	TRAFFIC BARRIER TERMINAL, TYPE 1 (SPECIAL) TANGENT	EACH	2	2			
* 63400105	GUARD POSTS	EACH	60	60			
64200116	SHOULDER RUMBLE STRIPS, 16 INCH	FOOT	176625	176625			
67000400	ENGINEER'S FIELD OFFICE, TYPE A	CAL MO	8	8			
67000600	ENGINEER'S FIELD LABORATORY	CAL MO	8	8			
67100100	MOBILIZATION	LSUM	1	1			
70100405	TRAFFIC CONTROL AND PROTECTION, STANDARD	EACH	1				1
	701321						

\* SPECIALTY ITEM

MODEL: Default  
 FILE: Model: 322A (46,47)RS-3, (58-20-1)RS-1  
 PROJECT: 74779 CAD Data CAD Sheets 074779-01-500.dgn

USER NAME = steffenmk	DESIGNED -	REVISED -
PLOT SCALE = 100.0000' / in.	DRAWN -	REVISED -
PLOT DATE = 1/29/2020	CHECKED -	REVISED -
	DATE -	REVISED -

**STATE OF ILLINOIS  
DEPARTMENT OF TRANSPORTATION**

**SUMMARY OF QUANTITIES**

SCALE: SHEET OF SHEETS STA. TO STA.

F.A.P. RTE.	SECTION	COUNTY	TOTAL SHEETS	SHEET NO.
322A	(46,47)RS-3, (58-20-1)RS-1	MACON	84	5
CONTRACT NO. 74779			ILLINOIS FED. AID PROJECT	

ILLINOIS DEPARTMENT OF TRANSPORTATION			TOTAL QUANTITIES				
CODE NO	ITEM	UNIT		0005	0047 S.N. 058-0122	0047 S.N. 058-0123	0047 S.N. 058-0124
70100420	TRAFFIC CONTROL AND PROTECTION, STANDARD	EACH	4	4			
	701411						
70100700	TRAFFIC CONTROL AND PROTECTION, STANDARD	L SUM	1	1			
	701406						
70100800	TRAFFIC CONTROL AND PROTECTION, STANDARD	LSUM	1	1			
	701401						
70100820	TRAFFIC CONTROL AND PROTECTION, STANDARD	LSUM	1	0.5	0.5		
	701451						
70100825	TRAFFIC CONTROL AND PROTECTION, STANDARD	L SUM	1	1			
	701456						
70106500	TEMPORARY BRIDGE TRAFFIC SIGNALS	EACH	1			1	
70107025	CHANGEABLE MESSAGE SIGN	CAL DA	112	112			
70300100	SHORT TERM PAVEMENT MARKING	FOOT	18862	18862			
70300150	SHORT TERM PAVEMENT MARKING REMOVAL	SO FT	9757	9757			
70300210	TEMPORARY PAVEMENT MARKING LETTERS AND SYMBOLS	SO FT	983	983			
70300220	TEMPORARY PAVEMENT MARKING - LINE 4"	FOOT	201970	201970			

REV. - MS

ILLINOIS DEPARTMENT OF TRANSPORTATION			TOTAL QUANTITIES	80% FED 20% STATE			
SUMMARY OF QUANTITIES				0005	0047 S.N. 058-0122	0047 S.N. 058-0123	0047 S.N. 058-0124
CODE NO	ITEM	UNIT					
70400100	TEMPORARY CONCRETE BARRIER	FOOT	550			550	
70400200	RELOCATE TEMPORARY CONCRETE BARRIER	FOOT	437.5			437.5	
70600250	IMPACT ATTENUATORS, TEMPORARY (NON-REDIRECTIVE), TEST LEVEL 3	EACH	2			2	
70600350	IMPACT ATTENUATORS, RELOCATE (NON-REDIRECTIVE), TEST LEVEL 3	EACH	2			2	
* 72501000	TERMINAL MARKER - DIRECT APPLIED	EACH	2	2			
* 78000100	THERMOPLASTIC PAVEMENT MARKING - LETTERS AND SYMBOLS	SO FT	437	437			
* 78000200	THERMOPLASTIC PAVEMENT MARKING - LINE 4"	FOOT	194450	194450			
* 78000400	THERMOPLASTIC PAVEMENT MARKING - LINE 6"	FOOT	3826	3826			
* 78000500	THERMOPLASTIC PAVEMENT MARKING - LINE 8"	FOOT	6782	6782			
* 78000600	THERMOPLASTIC PAVEMENT MARKING - LINE 12"	FOOT	2000	2000			
* 78000650	THERMOPLASTIC PAVEMENT MARKING - LINE 24"	FOOT	160	160			
* 78004230	PREFORMED PLASTIC PAVEMENT MARKING, TYPE B - INLAID - LINE 6"	FOOT	24840	24840			

\* SPECIALTY ITEM

ILLINOIS DEPARTMENT OF TRANSPORTATION			TOTAL QUANTITIES				
CODE NO	ITEM	UNIT		0005	0047 S.N. 058-0122	0047 S.N. 058-0123	0047 S.N. 058-0124
* 78100100	RAISED REFLECTIVE PAVEMENT MARKER	EACH	2270	2270			
* 78200005	GUARDRAIL REFLECTORS, TYPE A	EACH	7	7			
X0320586	FLEXIBLE DELINEATORS	EACH	16	16			
X0326440	SURFACE REMOVAL, VARIABLE DEPTH (SPECIAL)	SO YD	4041	4041			
X4060995	TEMPORARY RAMP, SPECIAL	SO YD	229	229			
X4401198	HOT-MIX ASPHALT SURFACE REMOVAL, VARIABLE DEPTH	SO YD	735	735			
X4403300	CONCRETE MEDIAN REMOVAL	SO FT	65	65			
X6061300	CONCRETE MEDIAN, TYPE SB-6.06 (DOWELLED)	SO FT	645	645			
X7011800	TRAFFIC CONTROL AND PROTECTION, STANDARD BLR 21	L SUM	1		1		
* X7830068	GROOVING FOR RECESSED PAVEMENT MARKING, LETTERS, NUMBERS AND SYMBOLS	SO FT	437	437			
* X7830070	GROOVING FOR RECESSED PAVEMENT MARKING 5"	FOOT	194450	194450			
* X7830074	GROOVING FOR RECESSED PAVEMENT MARKING 7"	FOOT	3826	3826			
* X7830076	GROOVING FOR RECESSED PAVEMENT MARKING 9"	FOOT	6782	6782			

\* SPECIALTY ITEM



ILLINOIS DEPARTMENT OF TRANSPORTATION			TOTAL QUANTITIES					
SUMMARY OF QUANTITIES				0005	0047 S.N. 058-0122	0047 S.N. 058-0123	0047 S.N. 058-0124	
CODE NO	ITEM	UNIT						
* X7830078	GROOVING FOR RECESSED PAVEMENT MARKING 13"	FOOT	2000	2000				
* X7830090	GROOVING FOR RECESSED PAVEMENT MARKING 25"	FOOT	160	160				
Z0016200	DECK SLAB REPAIR (PARTIAL)	SQ YD	5		5			
Z0016702	DETOUR SIGNING	L SUM	1	0.5	0.5			
Z0021908	SILICONE JOINT SEALER, 2"	FOOT	78			78		
Z0033700	LONGITUDINAL JOINT SEALANT	FOOT	111201	111201				
Z0034105	MATERIAL TRANSFER DEVICE	TON	65852	65852				
Z0041895	POLYMER CONCRETE	CU FT	6			6		
Ø Z0076600	TRAINEES	HOUR	1000	1000				
Ø Z0076604	TRAINEES TRAINING PROGRAM GRADUATE	HOUR	1000	1000				

\* SPECIALTY ITEM Ø 0042

REV. - MS

MODEL: Default  
 FILE NAME: p:\highway\com.dot.illinois.gov\p\dot\DOT\Documents\DOT\_Offices\District 7\Projects\74779\CADD\DATA\CAD\Sheets\74779-915-500.dgn

USER NAME = steffennk	DESIGNED -	REVISED -	<b>STATE OF ILLINOIS DEPARTMENT OF TRANSPORTATION</b>	<b>SUMMARY OF QUANTITIES</b>				F.A.P. RTE.	SECTION	COUNTY	TOTAL SHEETS	SHEET NO.		
PLOT SCALE = 100.0000' / in.	DRAWN -	REVISED -		SCALE:	SHEET	OF	SHEETS	STA.	TO STA.	322A	(46,47)RS-3 (58-20-1)RS-1	MACON	84	9
PLOT DATE = 1/29/2020	CHECKED -	REVISED -		CONTRACT NO. 74779										
	DATE -	REVISED -		ILLINOIS FED. AID PROJECT										

### ① TYPICAL CROSS SECTIONS

- ② STATION 212+84.00 TO STATION 336+69.47
- ③ STATION 361+42.07 TO STATION 364+62.41
- ③ STATION 399+53.08 TO STATION 409+00.00
- ② STATION 428+50.00 TO STATION 438+47.06
- ② STATION 457+20.10 TO STATION 467+30.96BK
- ② STATION 1480+00.00AH TO STATION 1608+13.95
- ② STATION 1638+68.53 TO STATION 1648+07.76
- ③ STATION 1703+97.09 TO STATION 1710+47.92

- HOT MIX ASPHALT SURFACE REMOVAL 3 3/4"
- NORTHBOUND: STA 275+12 TO STA 279+58  
STA 281+08 TO STA 282+59
- SOUTHBOUND: STA 280+84 TO STA 282+59
- MATCH EXISTING CROSS SLOPE
- HOT-MIX ASPHALT SURFACE REMOVAL, 2"
- PAVED SHOULDER REMOVAL (6 1/4")
- HOT-MIX ASPHALT SURFACE REMOVAL, 8"

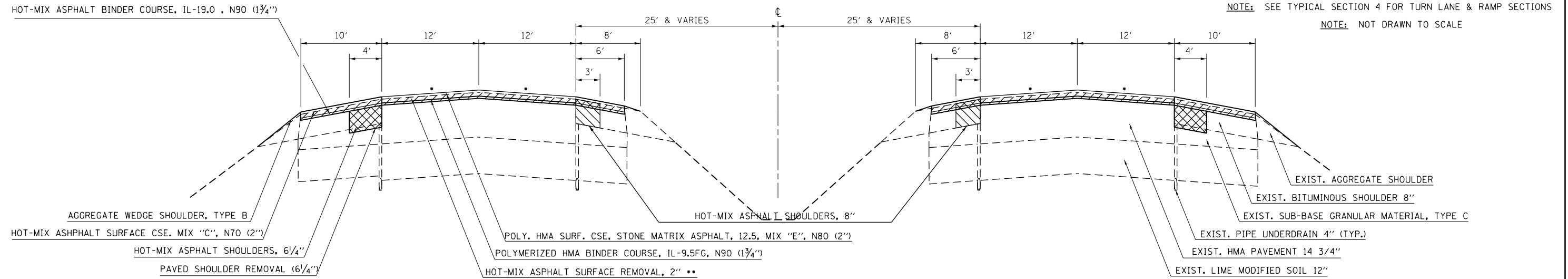

NOTE: SEE TYPICAL SECTION 4 FOR TURN LANE & RAMP SECTIONS  
NOTE: NOT DRAWN TO SCALE

### ② TYPICAL CROSS SECTIONS

- ① STATION 336+69.47 TO STATION 361+42.07
- ① STATION 438+47.06 TO STATION 457+20.10
- ① STATION 1608+13.95 TO STATION 1638+68.53

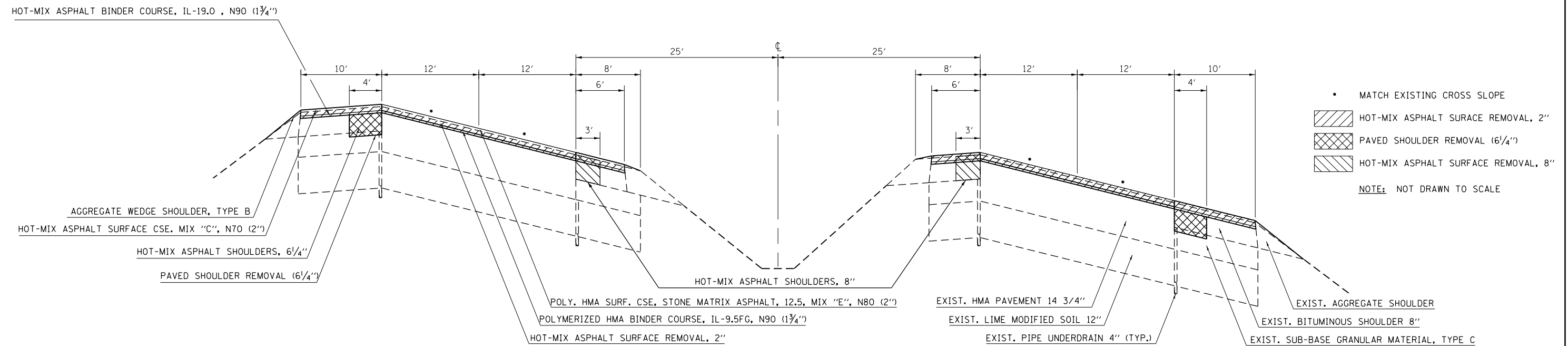

- MATCH EXISTING CROSS SLOPE
- HOT-MIX ASPHALT SURFACE REMOVAL, 2"
- PAVED SHOULDER REMOVAL (6 1/4")
- HOT-MIX ASPHALT SURFACE REMOVAL, 8"
- NOTE: NOT DRAWN TO SCALE

FILE NAME =	USER NAME = steffenmk	DESIGNED -	REVISED -	<b>STATE OF ILLINOIS DEPARTMENT OF TRANSPORTATION</b>	<b>TYPICAL CROSS SECTION</b>			F.A.P. RTE.	SECTION	COUNTY	TOTAL SHEETS	SHEET NO.	
pww\planroom.dot\illinois.gov\PWIDOT\Documents\DOT Offices\District 7\Projects\74779\CADDData\CADSheets\DRAWN-shi-typical.dgn		CHECKED -	REVISED -		SCALE: N/A	SHEET 1	OF 3 SHEETS	STA.	TO STA.	322A	(46,47)RS-3, (58-20-1)RS-1	MACON	84 10
Default	PLOT SCALE = 100.0000 ' / in.	DATE -	REVISED -		CONTRACT NO. 74779								
	PLOT DATE = 1/30/2020				ILLINOIS FED. AID PROJECT								

### ③ TYPICAL CROSS SECTIONS

- ① STATION 364+62.41 TO STATION 399+53.08
- ① STATION 1648+07.76 TO STATION 1703+97.09
- ① STATION 1710+47.92 TO STATION 1716+44.00

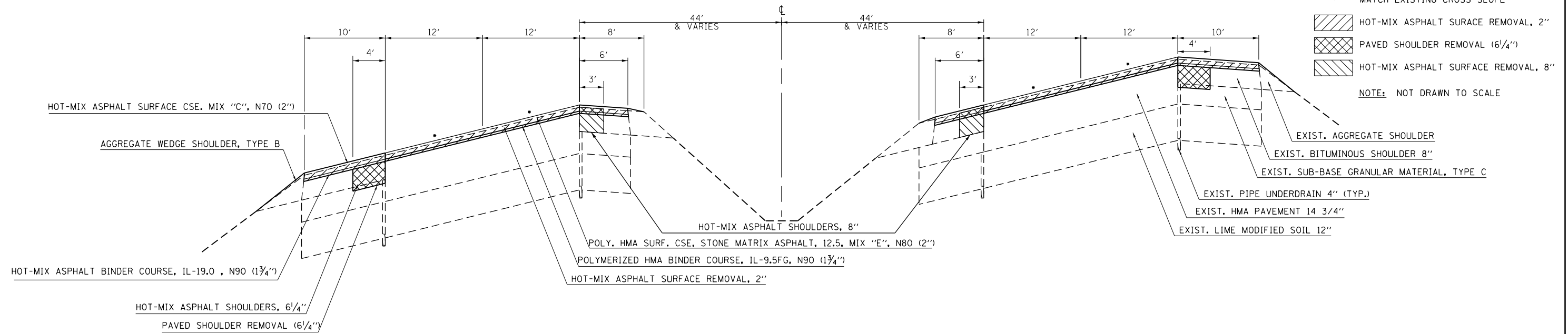

### ④ TYPICAL CROSS SECTIONS

- STATION 213+07.00 TO STATION 225+21.00
- STATION 243+69.00 TO STATION 253+09.00
- STATION 268+21.00 TO STATION 279+63.00
- STATION 296+12.00 TO STATION 305+52.00
- STATION 328+20.00 TO STATION 337+61.00
- STATION 355+07.00 TO STATION 365+61.00
- STATION 387+47.00 TO STATION 396+86.00

- STATION 430+12.00 TO STATION 440+54.00
- STATION 1480+61.00 TO STATION 1490+51.00
- STATION 1507+60.00 TO STATION 1516+97.00
- STATION 1535+03.00 TO STATION 1544+40.00
- STATION 221+21.45 TO STATION 228+72.06 (RAMP A)
- STATION 895+05.88 TO STATION 898+27.47 (RAMP D)
- STATION 1572+01.02 TO STATION 1579+34.33
- STATION 1574+11.97 TO STATION 1577+78.81

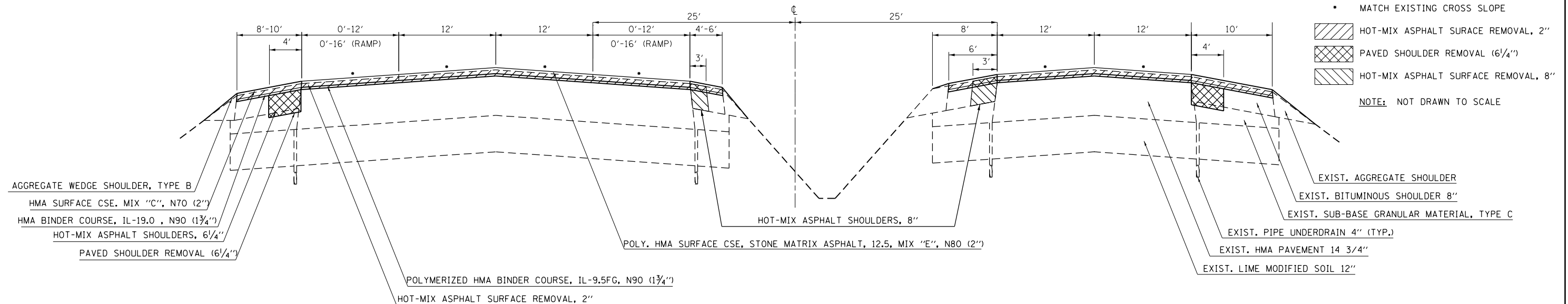

FILE NAME =	USER NAME = steffemk	DESIGNED -	REVISED -	<b>STATE OF ILLINOIS DEPARTMENT OF TRANSPORTATION</b>	<b>TYPICAL CROSS SECTION</b>			F.A.P. RTE.	SECTION	COUNTY	TOTAL SHEETS	SHEET NO.		
pww\planroom\dot_illinois.gov\PWIDOT\Documents\DOT Offices\District 7\Projects\74779\CADDData\CADSheets\DRAWN-shi-typical.dgn		CHECKED -	REVISED -		SCALE: N/A	SHEET 2	OF 3 SHEETS	STA.	TO STA.	322A	(46,47)RS-3, (58-20-1)RS-1	MACON	84	11
Default	PLOT SCALE = 100.0000 ' / in.	DATE -	REVISED -								CONTRACT NO. 74779			
	PLOT DATE = 1/30/2020										ILLINOIS FED. AID PROJECT			

### ⑤ TYPICAL CROSS SECTIONS

STATION 216+80.00 TO STATION 221+21.45 (RAMP A)  
 STATION 898+27.47 TO STATION 904+60.00 (RAMP D)

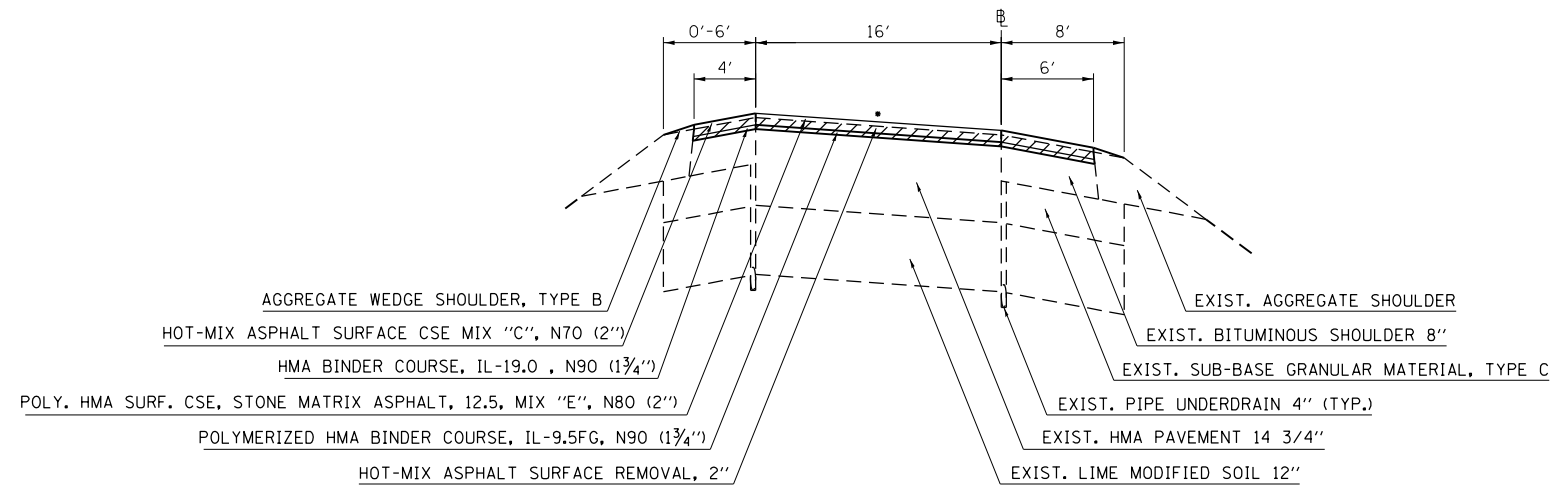

- MATCH EXISTING CROSS SLOPE
  - HOT-MIX ASPHALT SURFACE REMOVAL, 2"
  - PAVED SHOULDER REMOVAL (6 1/4")
- NOTE:** NOT DRAWN TO SCALE

### ⑥ TYPICAL CROSS SECTIONS

STATION 0+00.00 TO STATION 24+23.00 (RAMP E)  
 STATION 0+00.00 TO STATION 38+52.00 (RAMP F)

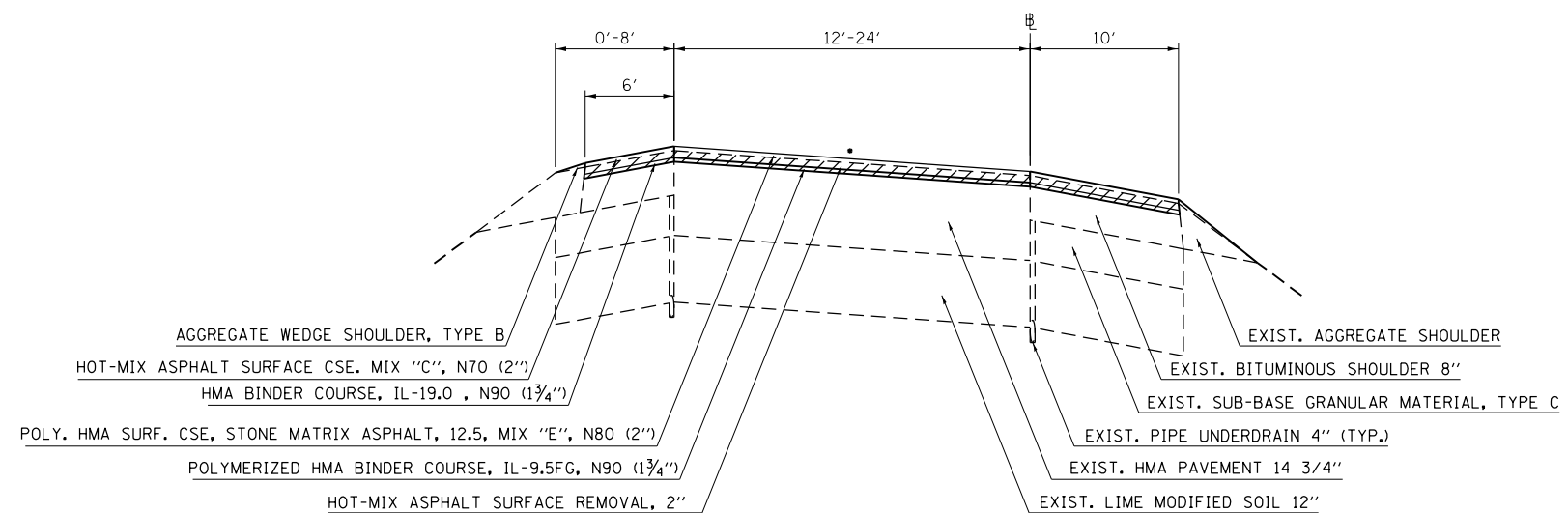

- MATCH EXISTING CROSS SLOPE
  - HOT-MIX ASPHALT SURFACE REMOVAL, 2"
  - PAVED SHOULDER REMOVAL (6 1/4")
- NOTE:** NOT DRAWN TO SCALE

FILE NAME =	USER NAME = steffemk	DESIGNED -	REVISED -	<b>STATE OF ILLINOIS DEPARTMENT OF TRANSPORTATION</b>	<b>TYPICAL CROSS SECTION</b>			F.A.P. RTE.	SECTION	COUNTY	TOTAL SHEETS	SHEET NO.
pww\planroom.dot.illinois.gov:PWIDOT\Documents\DOT Offices\District 7\Projects\74779\CADDData\CADsheets\DRAWN-shi-typical.dgn		CHECKED -	REVISED -					322A	(46,47)RS-3, (58-20-1)RS-1	MACON	84	12
Default	PLOT SCALE = 100.0000 ' / in.	DATE -	REVISED -		SCALE: N/A			SHEET 3 OF 3 SHEETS STA. TO STA.			CONTRACT NO. 74779	
	PLOT DATE = 1/29/2020							ILLINOIS FED. AID PROJECT				

# SCHEDULE OF QUANTITIES

## SURFACE REMOVAL - NORTHBOUND

STATIONING		LENGTH FEET	WIDTH					AREA					HOT-MIX ASPHALT SURFACE REMOVAL, BUTT-JOINT SQ YD	HOT-MIX ASPHALT SURFACE REMOVAL, VARIABLE DEPTH SQ YD	HOT-MIX ASPHALT SURFACE REMOVAL, 2" SQ YD	HOT-MIX ASPHALT SURFACE REMOVAL, 3 3/4" SQ YD	PAVED SHOULDER REMOVAL SQ YD	HOT-MIX ASPHALT SURFACE REMOVAL 8" SQ YD
			MAINLINE WIDTH FEET	LEFT TURN LANE WIDTH FEET	RIGHT TURN LANE WIDTH FEET	OUTSIDE SHOULDER WIDTH FEET	INSIDE SHOULDER WIDTH FEET	MAINLINE AREA SQ YD	LEFT TURN LANE AREA SQ YD	RIGHT TURN LANE AREA SQ YD	OUTSIDE SHOULDER AREA SQ YD	INSIDE SHOULDER AREA SQ YD						
212+84	213+07	23.0	24.0	-	-	10	8	61.3	-	-	25.6	20.4	245.0				10.2	7.7
213+07	215+86	279.0	24.0	6.0	-	10	8	744.0	186.0	-	310.0	248.0			1,488.0		124.0	93.0
215+86	218+57	271.0	24.0	12.0	-	10	8	722.7	361.3	-	301.1	240.9			1,626.0		120.4	0.0
218+57	220+42	185.0	24.0	-	-	10	8	493.3	-	-	205.6	88.9			787.8		82.2	0.0
220+42	243+69	2327.0	24.0	-	-	10	8	6,205.3	-	-	2,585.6	2,068.4			10,859.3		1034.2	775.7
243+69	245+98	229.0	24.0	6.0	-	10	8	610.7	152.7	-	254.4	203.6			1,221.3		101.8	76.3
245+98	248+05	207.0	24.0	12.0	-	10	8	552.0	276.0	-	230.0	184.0			1,242.0		92.0	0.0
248+05	248+71	66.0	24.0	-	-	10	8	176.0	-	-	73.3	44.4			293.8		29.3	0.0
248+71	249+17	46.0	24.0	2.7	-	10	8	122.7	13.8	-	51.1	40.9			228.5		20.4	15.3
249+17	268+21	1904.0	24.0	-	-	10	8	5,077.3	-	-	2,115.6	1,692.4			8,885.3		846.2	634.7
268+21	269+23	102.0	24.0	2.7	-	10	8-4	272.0	30.6	-	113.3	68.0			483.9		45.3	0.0
269+23	270+51	128.0	24.0	8.6	3.3	10-4	4	341.3	122.3	46.2	99.6	56.9			666.3		18.7	76.7
270+51	271+53	102.0	24.0	12.0	9.3	4	4	272.0	136.0	104.8	45.3	45.3			603.5			0.0
271+53	272+58	105.0	24.0	12.0	12.0	4	4	280.0	140.0	140.0	46.7	46.7			653.3			0.0
272+58	274+84	226.0	24.0	-	9.0	4	4	602.7	-	224.7	33.3	50.7			911.4			0.0
274+84	279+12	428.0	24.0	-	-	10	8	1,141.3	-	-	475.6	380.4			1,997.3		190.2	162.3
279+12	279+35	23.0	24.0	-	-	10	8	61.3	-	-	25.6	20.4		245.0			10.2	0.0
279+35	279+58	23.0	24.0	-	-	10	8	61.3	-	-	25.6	20.4				107.3	10.2	15.3
PAVING OMISSION S.N. 058-0125																		
281+08	282+36	128.0	24.0	-	-	10	8	341.3	-	-	142.2	113.8				597.3	56.9	42.7
282+36	282+59	23.0	24.0	-	-	10	8	61.3	-	-	25.6	20.4		245.0			10.2	7.7
282+59	296+12	1353.0	24.0	-	-	10	8	3,608.0	-	-	1,503.3	1,202.7			6,314.0		601.3	451.0
296+12	298+41	229.0	24.0	9.0	-	10	8	610.7	229.0	-	254.4	203.6			1,297.7		101.8	76.3
298+41	300+48	207.0	24.0	12.0	-	10	8	552.0	276.0	-	230.0	184.0			1,242.0		92.0	0.0
300+48	301+14	66.0	24.0	-	-	10	8	176.0	-	-	73.3	44.4			293.8		29.3	0.0
301+14	301+60	46.0	24.0	2.7	-	10	8	122.7	13.8	-	51.1	40.9			228.5		20.4	15.3
301+60	328+20	2660.0	24.0	-	-	10	8	7,093.3	-	-	2,955.6	2,364.4			12,413.3		1182.2	886.7
328+20	330+50	230.0	24.0	6.0	-	10	8	613.3	153.3	-	255.6	204.4			1,226.7		102.2	76.7
330+50	332+56	206.0	24.0	12.0	-	10	8	549.3	274.7	-	228.9	183.1			1,236.0		91.6	0.0
332+56	333+23	67.0	24.0	-	-	10	8	178.7	-	-	74.4	44.4			297.6		29.8	0.0
333+23	333+69	46.0	24.0	2.7	-	10	8	122.7	13.8	-	51.1	40.9			228.5		20.4	15.3
333+69	355+07	2138.0	24.0	-	-	10	8	5,701.3	-	-	2,375.6	1,900.4			9,977.3		950.2	713.0
355+07	357+38	231.0	24.0	6.0	6.0	8	4	616.0	154.0	154.0	205.3	102.7			1,232.0		9.8	76.7
357+38	359+70	232.0	24.0	12.0	12.0	8	4	618.7	309.3	309.3	157.3	103.1			1,497.8			0.0
359+70	360+96	126.0	24.0	-	-	8	4	336.0	-	-	-	6.7			342.7			0.0
360+96	361+61	65.0	24.0	6.3	6.3	10	8	173.3	45.7	45.7	72.2	57.8			394.7		28.9	21.7
361+61	387+47	2586.0	24.0	-	-	10	8	6,896.0	-	-	2,873.3	2,298.7			12,068.0		1149.3	862.0
387+47	389+78	231.0	24.0	6.0	-	10	8	616.0	154.0	-	256.7	205.3			1,232.0		102.7	77.0
389+78	391+83	205.0	24.0	12.0	-	10	8	546.7	273.3	-	227.8	182.2			1,230.0		91.1	0.0
391+83	392+50	67.0	24.0	-	-	10	8	178.7	-	-	74.4	44.4			297.6		29.8	0.0
392+50	392+95	45.0	24.0	2.7	-	10	8	120.0	13.5	-	50.0	40.0			223.5		20.0	15.0
392+95	409+00	1605.0	24.0	-	-	10	8	5,472.0	-	-	2,280.0	1,824.0	245.0		9,576.0		713.3	535.0
NORTHBOUND SUB-TOTAL 1 =													490.0	490.0	94,797.3	704.6	8,168.9	5,729.1

FILE NAME =	USER NAME = steffenmk	DESIGNED -	REVISED -	<b>STATE OF ILLINOIS DEPARTMENT OF TRANSPORTATION</b>	<b>SCHEDULE OF QUANTITIES</b>	F.A.P. RTE.	SECTION	COUNTY	TOTAL SHEETS	SHEET NO.
pw\planroom.dot\illinois.gov\PWIDOT\Documents\DOT Offices\District 7\Projects\74779\CADDData\CADSheets\DRAWN-sh-t-schedule.dgn						322A	(46,47)RS-3, (58-20-1)RS-1	MACON	84	13
Default	PLOT SCALE = 100.0000' / in.	CHECKED -	REVISED -						CONTRACT NO. 74779	
	PLOT DATE = 1/29/2020	DATE -	REVISED -		SCALE: N/A	SHEET 1	OF 16 SHEETS	STA.	TO STA.	
									ILLINOIS   FED. AID PROJECT	

# SCHEDULE OF QUANTITIES

## SURFACE REMOVAL - NORTHBOUND (CONTINUED)

STATIONING		LENGTH FEET	WIDTH					AREA					HOT-MIX ASPHALT SURFACE REMOVAL, BUTT-JOINT SQ YD	HOT-MIX ASPHALT SURFACE REMOVAL, VARIABLE DEPTH SQ YD	HOT-MIX ASPHALT SURFACE REMOVAL, 2" SQ YD	HOT-MIX ASPHALT SURFACE REMOVAL, 3 3/4" SQ YD	PAVED SHOULDER REMOVAL SQ YD	HOT-MIX ASPHALT SURFACE REMOVAL 8" SQ YD
			MAINLINE WIDTH FEET	LEFT TURN LANE WIDTH FEET	RIGHT TURN LANE WIDTH FEET	OUTSIDE SHOULDER WIDTH FEET	INSIDE SHOULDER WIDTH FEET	MAINLINE AREA SQ YD	LEFT TURN LANE AREA SQ YD	RIGHT TURN LANE AREA SQ YD	OUTSIDE SHOULDER AREA SQ YD	INSIDE SHOULDER AREA SQ YD						
428+50	430+12	162.0	24.0	-	-	10.0	8.0	2,701.3	-	-	1,125.6	900.4	245.0	X4401198	44000157	44000164	44004250	44000182
430+12	432+42	230.0	24.0	6.0	-	10.0	4.0	613.3	153.3	-	255.6	102.2			1,124.4		102.2	76.7
432+42	434+48	206.0	24.0	12.0	-	10.0	4.0	549.3	274.7	-	228.9	91.6			1,144.4		91.6	0.0
434+48	436+79	231.0	24.0	-	-	10.0	8-4	616.0	-	-	256.7	72.7			945.3		102.7	0.0
436+79	467+30.956	3052.0	24.0	-	-	10.0	8.0	8,138.5	-	-	3,391.1	2,712.8			14,242.5		1356.4	1017.3
STATION EQUATION: STA. 467+30.96 (BK.) = STA. 1480+00.00 (AH.)																		
1480+00	1480+61	61.0	24.0	1.8	-	10.0	8-4	162.7	12.2	-	67.8	40.7			283.3		27.1	20.3
1480+61	1482+23	162.0	24.0	7.8	4.4	10-4	4.0	432.0	140.4	78.3	126.0	72.0			848.7		16.9	12.7
1482+23	1482+91	68.0	24.0	12.0	10.4	4.0	4.0	181.3	90.7	78.2	30.2	30.2			410.6			0.0
1482+91	1484+28	137.0	24.0	12.0	12.0	4.0	4.0	365.3	182.7	182.7	60.9	60.9			852.4			0.0
1484+28	1486+09	181.0	24.0	-	-	4.0	4-8	482.7	-	-	16.4	74.7			573.8			0.0
1486+09	1507+60	2151.0	24.0	-	-	10.0	8.0	5,736.0	-	-	2,390.0	1,912.0			10,038.0		956.0	717.0
1507+60	1509+90	230.0	24.0	6.0	-	10.0	8.0	613.3	153.3	-	255.6	204.4			1,226.7		102.2	76.7
1509+90	1511+95	205.0	24.0	12.0	-	10.0	8.0	546.7	273.3	-	227.8	182.2			1,230.0		91.1	0.0
1511+95	1512+60	65.0	24.0	-	-	10.0	8.0	173.3	-	-	72.2	44.4			290.0		28.9	0.0
1512+60	1513+12	52.0	24.0	3.0	-	10.0	8.0	138.7	17.3	-	57.8	46.2			260.0		23.1	17.3
1513+12	1535+03	2191.0	24.0	-	-	10.0	8.0	5,842.7	-	-	2,434.4	1,947.6			10,224.7		973.8	730.3
1535+03	1537+33	230.0	24.0	6.0	-	10.0	8.0	613.3	153.3	-	255.6	204.4			1,226.7		102.2	76.7
1537+33	1539+38	205.0	24.0	12.0	-	10.0	8.0	546.7	273.3	-	227.8	182.2			1,230.0		91.1	0.0
1539+38	1540+03	65.0	24.0	-	-	10.0	8.0	173.3	-	-	72.2	42.7			288.2		28.9	0.0
1540+03	1540+55	52.0	24.0	3.0	-	10.0	8.0	138.7	17.3	-	57.8	46.2			260.0		23.1	17.3
1540+55	1577+78	3723.0	24.0	-	-	10.0	8.0	9,928.0	-	-	4,136.7	3,309.3			17,374.0		1514.2	1135.7
1577+78	1599+13	2135.0	24.0	-	-	-	8.0	5,693.3	-	-	-	1,897.8			7,591.1		152.4	711.7
1599+13	1706+07	10694.0	24.0	-	-	10.0	8.0	28,517.3	-	-	11,882.2	9,505.8			49,905.3		4752.9	3564.7
1706+07	1712+70	663.0	24.0	-	-	-	8.0	1,768.0	-	-	-	589.3			2,357.3		58.7	221.0
1712+70	1716+21	351.0	24.0	-	-	10.0	8.0	936.0	-	-	390.0	312.0			1,638.0		156.0	117.0
1716+21	1716+44	23.0	24.0	-	-	10.0	8.0	61.3	-	-	25.6	20.4	245.0				10.2	7.7
NORTHBOUND SUB-TOTAL 2 =												490.0	0.0	130,292.9	0.0	10,833.8	8,574.1	

NORTHBOUND SUB-TOTAL 1 =	490.0	490.0	94,797.3	704.6	8,168.9	5,729.1
NORTHBOUND SUB-TOTAL 2 =	490.0	0.0	130,292.9	0.0	10,833.8	8,574.1
NORTHBOUND TOTAL =	980.0	490.0	225,090.2	704.6	19,002.6	14,303.2

# SCHEDULE OF QUANTITIES

## SURFACE REMOVAL - SOUTHBOUND

STATIONING		LENGTH FEET	WIDTH					AREA					HOT-MIX ASPHALT SURFACE REMOVAL, BUTT-JOINT SQ YD	HOT-MIX ASPHALT SURFACE REMOVAL, VARIABLE DEPTH SQ YD	HOT-MIX ASPHALT SURFACE REMOVAL, 2" SQ YD	HOT-MIX ASPHALT SURFACE REMOVAL, 3 3/4" SQ YD	PAVED SHOULDER REMOVAL SQ YD	HOT-MIX ASPHALT SURFACE REMOVAL 8" SQ YD
			MAINLINE WIDTH FEET	LEFT TURN LANE WIDTH FEET	RIGHT TURN LANE WIDTH FEET	OUTSIDE SHOULDER WIDTH FEET	INSIDE SHOULDER WIDTH FEET	MAINLINE AREA SQ YD	LEFT TURN LANE AREA SQ YD	RIGHT TURN LANE AREA SQ YD	OUTSIDE SHOULDER AREA SQ YD	INSIDE SHOULDER AREA SQ YD						
FROM	TO																	
212+84	213+07	23.0	24.0	-	-	10.0	8.0	61.3	-	-	25.6	20.4	245.0				10.2	7.7
213+07	217+86	479.0	24.0	-	-	10.0	8.0	1,277.3	-	-	532.2	425.8			2,235.3		212.9	159.7
217+86	219+71	185.0	24.0	-	-	10.0	8.0	493.3	-	-	205.6	88.9			787.8		82.2	0.0
219+71	222+42	271.0	24.0	12.0	-	10.0	8.0	722.7	361.3	-	301.1	240.9			1,626.0		120.4	0.0
222+42	225+21	279.0	24.0	6.0	-	10.0	8.0	744.0	186.0	-	310.0	248.0			1,488.0		124.0	93.0
225+21	247+60	2239.0	24.0	-	-	10.0	8.0	5,970.7	-	-	2,487.8	1,990.2			10,448.7		995.1	746.3
247+60	248+07	47.0	24.0	3	-	10.0	8.0	125.3	14.1	-	52.2	44.4			236.1		20.9	15.7
248+07	248+73	66.0	24.0	-	-	10.0	8.0	176.0	-	-	73.3	58.7			308.0		29.3	0.0
248+73	250+80	207.0	24.0	12.0	-	10.0	8.0	552.0	276.0	-	230.0	184.0			1,242.0		92.0	0.0
250+80	253+09	229.0	24.0	6.0	-	10.0	8.0	610.7	152.7	-	254.4	203.6			1,221.3		101.8	76.3
253+09	273+25	2016.0	24.0	-	-	10.0	8.0	5,376.0	-	-	2,240.0	1,792.0			9,408.0		896.0	672.0
273+25	274+25	100.0	24.0	-	-	-	4.0	266.7	-	-	-	15.6			282.2			0.0
274+25	275+24	99.0	24.0	23.9	12.0	4.0	4.0	264.0	262.4	132.0	44.0	44.0			746.4			0.0
275+24	276+30	106.0	24.0	12.0	12.0	4.0	4.0	282.7	141.3	141.3	47.1	47.1			659.5			0.0
276+30	277+31	101.0	24.0	12.0	9.6	4.0	4.0	269.3	134.7	107.7	44.9	44.9			601.5			0.0
277+31	278+62	131.0	24.0	8.4	2.8	10-4	4.0	349.3	122.3	40.4	101.9	58.2			672.1		24.9	18.7
278+62	279+12	50.0	24.0	3.5	-	10.0	4.0	133.3	19.4	-	55.6	22.2			230.6		22.2	16.7
279+12	279+35	23.0	24.0	1.9	-	10.0	8-4	61.3	-	-	25.6	15.3	245.0				10.2	7.7
PAVING OMISSION S.N. 058-0125																		
280+84	282+36	152.0	24.0	-	-	10.0	8.0	405.3	-	-	168.9	135.1				709.3	67.6	50.7
282+36	282+59	23.0	24.0	-	-	10.0	8.0	61.3	-	-	25.6	20.4		245.0			10.2	7.7
282+59	300+03	1744.0	24.0	-	-	10.0	8.0	4,650.7	-	-	1,937.8	1,550.2			8,138.7		775.1	581.3
300+03	300+50	47.0	24.0	2.7	-	10.0	8.0	125.3	14.1	-	52.2	41.8			233.4		20.9	15.7
300+50	301+15	65.0	24.0	-	-	10.0	8.0	173.3	-	-	72.2	44.4			290.0		28.9	0.0
301+15	303+22	207.0	24.0	12	-	10.0	8.0	552.0	276.0	-	230.0	184.0			1,242.0		92.0	0.0
303+22	305+52	230.0	24.0	6	-	10.0	8.0	613.3	153.3	-	255.6	204.4			1,226.7		102.2	76.7
305+52	332+12	2660.0	24.0	-	-	10.0	8.0	7,093.3	-	-	2,955.6	2,364.4			12,413.3		1182.2	886.7
332+12	332+58	46.0	24.0	2.7	-	10.0	8.0	122.7	13.8	-	51.1	40.9			228.5		20.4	15.3
332+58	333+24	66.0	24.0	-	-	10.0	8.0	176.0	-	-	73.3	44.4			293.8		29.3	0.0
333+24	335+31	207.0	24.0	12	-	10.0	8.0	552.0	276.0	-	230.0	184.0			1,242.0		92.0	0.0
335+31	337+61	230.0	24.0	6	-	10.0	8.0	613.3	153.3	-	255.6	204.4			1,226.7		102.2	76.7
337+61	359+06	2145.0	24.0	-	-	10.0	8.0	5,720.0	-	-	2,383.3	1,906.7			10,010.0		953.3	715.0
359+06	359+72	66.0	24.0	12.7	-	10.0	8-4	176.0	92.8	-	66.0	44.0			378.8		29.3	22.0
359+72	360+99	127.0	24.0	-	-	10-8	4.0	338.7	-	-	44.4	6.2			389.3			0.0
360+99	363+26	227.0	24.0	12	12	8.0	4.0	605.3	302.7	302.7	155.6	100.9			1,467.1			0.0
363+26	363+32	6.0	24.0	12	11.9	8.0	4.0	16.0	8.0	7.9	5.3	2.7			39.9		2.7	0.0
363+32	365+56	224.0	24.0	6.2	5.9	8.0	4.0	597.3	153.1	145.6	199.1	99.6			1,194.7		17.3	13.0
365+56	365+61	5.0	24.0	0.2	-	8.0	4.0	13.3	0.1	-	5.6	4.4			23.4		2.2	1.7
365+61	391+40	2579.0	24.0	-	-	10.0	8.0	6,877.3	-	-	2,865.6	2,292.4			12,035.3		1146.2	859.7
391+40	391+86	46.0	24.0	2.7	-	10.0	8.0	122.7	13.8	-	51.1	40.9			228.5		20.4	15.3
391+86	392+51	65.0	24.0	-	-	10.0	8.0	173.3	-	-	72.2	44.4			290.0		28.9	0.0
392+51	394+58	207.0	24.0	12	-	10.0	8.0	552.0	276.0	-	230.0	184.0			1,242.0		92.0	0.0
394+58	396+86	228.0	24.0	6	-	10.0	8.0	608.0	152.0	-	253.3	202.7			1,216.0		101.3	76.0
396+86	409+00	1214.0	24.0	-	-	10.0	8.0	5,546.7	-	-	2,311.1	1,848.9	245.0		9,706.7		539.6	404.7
SOUTHBOUND SUB-TOTAL 1 =													735.0	245.0	96,950.2	709.3	8,198.7	5,631.8





# SCHEDULE OF QUANTITIES

## SURFACE REMOVAL - RAMPS

STATIONING		LENGTH	WIDTH			AREA			HOT-MIX ASPHALT SURFACE REMOVAL, BUTT-JOINT	HOT-MIX ASPHALT SURFACE REMOVAL, 2"
			PAVEMENT	INSIDE SHOULDER	OUTSIDE SHOULDER	PAVEMENT	INSIDE SHOULDER	OUTSIDE SHOULDER		
FROM	TO	FEET	WIDTH FEET	WIDTH SQ YD	WIDTH SQ YD	AREA SQ YD	AREA SQ YD	AREA SQ YD	40600982 SQ YD	44000157 SQ YD
<b>RAMP E</b>										
-3+67	0+00	367	6.7	-	-	273.2	-	-		273.2
0+00	3+00	300	18.7	10.0	-	623.3	333.3	-		956.7
3+00	17+92	1492	24.0	10.0	-	3,978.7	1,657.8	-		5,636.4
17+92	21+35	343	24.0	10.0	9.0	914.7	381.1	343.0		1,638.8
21+35	24+08	273	24.0	10.0	8.0	728.0	303.3	242.7		1,274.0
24+08	24+23	15	24.0	10.0	8.0	40.0	-	-	163.3	40.0
<b>RAMP E TOTAL =</b>									163.3	9,819.1
<b>RAMP F</b>										
-7+33	0+00	733	6.7	-	-	545.7	-	-		545.7
0+00	6+00	600	18.7	10.0	-	1,246.7	666.7	-		1,913.3
6+00	16+00	1000	24.0	10.0	-	2,666.7	1,111.1	-		3,777.8
16+00	27+77	1177	24.0	10.0	9.0	3,138.7	1,307.8	1,177.0		5,623.4
27+77	38+37	1060	24.0	10.0	8.0	2,826.7	1,177.8	942.2		4,946.7
38+37	38+52	15	24.0	10.0	8.0	40.0	-	-	163.3	40.0
<b>RAMP F TOTAL =</b>									163.3	16,846.9
<b>RAMP D</b>										
895+06	900+36	530	8.0	8.0	-	471.1	471.1	-		942.2
900+36	901+68	132	16.0	8.0	10.0	234.7	117.3	146.7		498.7
901+68	904+45	277	16.0	8.0	6.0	492.4	246.2	184.7		923.3
904+45	904+60	15	16.0	8.0	6.0	26.7	-	-	101.1	26.7
<b>RAMP D TOTAL =</b>									101.1	2,390.9
<b>RAMP A</b>										
216+80	216+95	15	16.0	8.0	6.0	26.7	-	-	101.1	26.7
216+95	221+21	426	16.0	8.0	10.0	757.3	378.7	473.3		1,609.3
221+21	228+72	751	8.0	8.0	-	667.6	667.6	-		1,335.1
<b>RAMP A TOTAL =</b>									101.1	2,971.1
<b>RAMP TOTAL =</b>									528.8	32,027.9

## SURFACE REMOVAL - CROSSOVERS

STATION	HOT-MIX ASPHALT SURFACE REMOVAL, 2"
	44000157 SQ YD
219+14	724.6
248+39	205.1
273+91	744.0
300+82	202.0
332+90	205.0
360+35	277.4
392+18	203.6
435+94	903.4
1485+22	614.4
1512+28	188.3
1539+71	186.4
<b>TOTAL =</b>	<b>4,454.3</b>

## SURFACE REMOVAL SUMMARY

LOCATION	HOT-MIX ASPHALT SURFACE REMOVAL, BUTT-JOINT	HOT-MIX ASPHALT SURFACE REMOVAL, VARIABLE DEPTH	HOT-MIX ASPHALT SURFACE REMOVAL, 2"	HOT-MIX ASPHALT SURFACE REMOVAL, 3 3/4"	PAVED SHOULDER REMOVAL	HOT-MIX ASPHALT SURFACE REMOVAL 8"
	40600982 SQ YD	X4401198 SQ YD	44000157 SQ YD	44000164 SQ YD	44004250 SQ YD	44000182 SQ YD
NORTHBOUND	980.0	490.0	225,090.2	704.6	19,002.6	14303.2
SOUTHBOUND	1,225.0	245.0	224,516.6	709.3	18,833.8	14,315.5
<b>RAMPS</b>	<b>528.8</b>		<b>32,027.9</b>			
<b>CROSSOVERS</b>			<b>4,454.3</b>			
<b>PRAS</b>						
<b>TOTAL</b>	<b>2,733.8</b>	<b>735.0</b>	<b>486,089.1</b>	<b>1,413.9</b>	<b>37,836.4</b>	<b>28,618.7</b>
<b>ROUND TO</b>	<b>2,734.0</b>	<b>735.0</b>	<b>486,090.0</b>	<b>1,414.0</b>	<b>37,837.0</b>	<b>28,619.0</b>

# SCHEDULE OF QUANTITIES

## HOT-MIX ASPHALT - NORTHBOUND

STATIONING		LENGTH					WIDTH				AREA					BITUMINOUS MATERIALS (TACK COAT)	POLYMERIZED HOT-MIX ASPHALT BINDER COURSE, IL-9.5FG, N90	POLYMERIZED HOT-MIX ASPHALT SURFACE COURSE, STONE MATRIX ASPHALT, 12.5, MIX "E", N80	HOT-MIX ASPHALT SURFACE COURSE, MIX "C", N 70	HOT-MIX ASPHALT BINDER COURSE, IL-19.0, N70	HOT-MIX ASPHALT SHOULDERS, 6 1/4"	HOT-MIX ASPHALT SHOULDERS, 8"	
		LEGNTH	LEFT TURN LANE LENGTH	RIGHT TURN LANE LENGTH	OUTSIDE SHOULDER LENGTH	INSIDE SHOULDER LENGTH	LEFT TURN LANE WIDTH	RIGHT TURN LANE WIDTH	OUTSIDE SHOULDER WIDTH	INSIDE SHOULDER WIDTH	MAINLINE AREA	LEFT TURN LANE AREA	RIGHT TURN LANE AREA	OUTSIDE SHOULDER AREA	INSIDE SHOULDER AREA								TOTAL SHOULDER AREA
		FEET	FEET	FEET	FEET	FEET	FEET	FEET	FEET	FEET	SO YD	SO YD	SO YD	SO YD	SO YD								SO YD
212+84	213+07	23	-	-	23	23	-	-	10	6	61.3	-	-	25.6	15.3	40.9	69.0	6.0	8.0	4.6	4.0	10.2	7.7
213+07	215+86	279	279	-	279	279	0-12	-	10	6	744.0	186.0	-	310.0	186.0	496.0	962.6	91.1	120.9	55.6	48.6	124.0	93.0
215+86	218+57	271	271	-	271	271	12	-	10	6	722.7	361.3	-	301.1	180.7	481.8	1,056.9	106.2	140.9	54.0	47.2	120.4	0.0
218+57	220+42	185	-	-	185	100	-	-	10	6	493.3	-	-	205.6	66.7	272.2	516.8	48.3	64.1	30.5	26.7	82.2	0.0
220+42	243+69	2327	-	-	2327	2327	-	-	10	6	6,205.3	-	-	2,585.6	1,551.3	4,136.9	6,981.0	608.1	806.7	463.3	405.4	1034.2	775.7
243+69	245+98	229	229	-	229	229	0-12	-	10	6	610.7	152.7	-	254.4	152.7	407.1	790.1	74.8	99.2	45.6	39.9	101.8	76.3
245+98	248+05	207	207	-	207	207	12	-	10	6	552.0	276.0	-	230.0	138.0	368.0	807.3	81.1	107.6	41.2	36.1	92.0	0.0
248+05	248+71	66	-	-	66	50	-	-	10	6	176.0	-	-	73.3	33.3	106.7	190.8	17.2	22.9	11.9	10.5	29.3	0.0
248+71	249+17	46	46	-	46	46	5.4-0	-	10	6	122.7	13.8	-	51.1	30.7	81.8	147.3	13.4	17.7	9.2	8.0	20.4	15.3
249+17	268+21	1904	-	-	1904	1904	-	-	10	6	5,077.3	-	-	2,115.6	1,269.3	3,384.9	5,712.0	497.6	660.1	379.1	331.7	846.2	634.7
268+21	269+23	102	102	-	102	102	0-5.2	-	10	6-4	272.0	30.6	-	113.3	56.7	170.0	319.0	29.7	39.3	19.0	16.7	45.3	0.0
269+23	270+51	128	128	128	128	128	5.2-12	0-6.5	10-4	4	341.3	122.3	46.2	99.6	56.9	156.4	449.8	50.0	66.3	17.5	15.3	18.7	76.7
270+51	271+53	102	102	102	102	102	12	6.5-12	4	4	272.0	136.0	104.8	45.3	45.3	90.7	407.4	50.3	66.7	10.2	8.9		0.0
271+53	272+58	105	105	105	105	105	12	12	4	4	280.0	140.0	140.0	46.7	46.7	93.3	441.0	54.9	72.8	10.5	9.1		0.0
272+58	274+84	226	-	226	75	114	-	12-5.9	4	4	602.7	-	224.7	33.3	50.7	84.0	615.2	81.1	107.6	9.4	8.2		0.0
274+84	279+12	428	-	-	428	428	-	-	10	6	1,141.3	-	-	475.6	285.3	760.9	1,284.0	111.9	148.4	85.2	74.6	190.2	162.3
279+12	279+35	23	-	-	23	23	-	-	10	6	61.3	-	-	25.6	15.3	40.9	69.0	6.0	8.0	4.6	4.0	10.2	0.0
279+35	279+58	23	-	-	23	23	-	-	10	6	61.3	-	-	25.6	15.3	40.9	69.0	6.0	8.0	4.6	4.0	10.2	15.3
PAVING OMISSION S.N. 058-0125																							
281+08	282+36	128	-	-	128	128	-	-	10	6	341.3	-	-	142.2	85.3	227.6	384.0	33.5	44.4	25.5	22.3	56.9	42.7
282+36	282+59	23	-	-	23	23	-	-	10	6	61.3	-	-	25.6	15.3	40.9	69.0	6.0	8.0	4.6	4.0	10.2	7.7
282+59	296+12	1353	-	-	1353	1353	-	-	10	6	3,608.0	-	-	1,503.3	902.0	2,405.3	4,059.0	353.6	469.0	269.4	235.7	601.3	451.0
296+12	298+41	229	229	-	229	229	0-12	-	10	6	610.7	152.7	-	254.4	152.7	407.1	790.1	74.8	99.2	45.6	39.9	101.8	76.3
298+41	300+48	207	207	-	207	207	12	-	10	6	552.0	276.0	-	230.0	138.0	368.0	807.3	81.1	107.6	41.2	36.1	92.0	0.0
300+48	301+14	66	-	-	66	50	-	-	10	6	176.0	-	-	73.3	33.3	106.7	190.8	17.2	22.9	11.9	10.5	29.3	0.0
301+14	301+60	46	46	-	46	46	5.4-0	-	10	6	122.7	13.8	-	51.1	30.7	81.8	147.3	13.4	17.7	9.2	8.0	20.4	15.3
301+60	328+20	2660	-	-	2660	2660	-	-	10	6	7,093.3	-	-	2,955.6	1,773.3	4,728.9	7,980.0	695.1	922.1	529.6	463.4	1182.2	886.7
328+20	330+50	230	230	-	230	230	0-12	-	10	6	613.3	153.3	-	255.6	153.3	408.9	793.5	75.1	99.7	45.8	40.1	102.2	76.7
330+50	332+56	206	206	-	206	206	12	-	10	6	549.3	274.7	-	228.9	137.3	366.2	803.4	80.8	107.1	41.0	35.9	91.6	0.0
332+56	333+23	67	-	-	67	50	-	-	10	6	178.7	-	-	74.4	33.3	107.8	193.4	17.5	23.2	12.1	10.6	29.8	0.0
333+23	333+69	46	46	-	46	46	5.4-0	-	10	6	122.7	13.8	-	51.1	30.7	81.8	147.3	13.4	17.7	9.2	8.0	20.4	15.3
333+69	355+07	2138	-	-	2138	2138	-	-	10	6	5,701.3	-	-	2,375.6	1,425.3	3,800.9	6,414.0	558.7	741.2	425.7	372.5	950.2	713.0
355+07	357+38	231	231	231	231	231	0-12	0-12	8	4	616.0	154.0	154.0	205.3	102.7	308.0	831.6	90.6	120.1	34.5	30.2	9.8	76.7
357+38	359+70	232	232	232	177	232	12	12	8	4	618.7	309.3	309.3	157.3	103.1	260.4	1,011.0	121.3	160.9	29.2	25.5		0.0
359+70	360+96	126	-	-	-	15	-	-	8	4	336.0	-	-	-	6.7	6.7	231.3	32.9	43.7	0.7	0.7		0.0
360+96	361+61	65	65	65	65	65	12.65-0	12.65-0	10	6	173.3	45.7	45.7	72.2	43.3	115.6	256.7	25.9	34.4	12.9	11.3	28.9	21.7
361+61	387+47	2586	-	-	2586	2586	-	-	10	6	6,896.0	-	-	2,873.3	1,724.0	4,597.3	7,758.0	675.8	896.5	514.9	450.5	1149.3	862.0
387+47	389+78	231	231	-	231	231	0-12	-	10	6	616.0	154.0	-	256.7	154.0	410.7	797.0	75.5	100.1	46.0	40.2	102.7	77.0
389+78	391+83	205	205	-	205	205	12	-	10	6	546.7	273.3	-	227.8	136.7	364.4	799.5	80.4	106.6	40.8	35.7	91.1	0.0
391+83	392+50	67	-	-	67	50	-	-	10	6	178.7	-	-	74.4	33.3	107.8	193.4	17.5	23.2	12.1	10.6	29.8	0.0
392+50	392+95	45	45	-	45	45	5.4-0	-	10	6	120.0	13.5	-	50.0	30.0	80.0	144.1	13.1	17.4	9.0	7.8	20.0	15.0
392+95	409+00	1605	-	-	1605	1605	-	-	10	6	4,280.0	-	-	1,783.3	1,070.0	2,853.3	4,815.0	419.4	556.4	319.6	279.6	912.0	535.0
NORTHBOUND SUB-TOTAL 1 =																	60,504.6	5,506.3	7,304.3	3,746.3	3,278.0	8,367.6	5,729.1

# SCHEDULE OF QUANTITIES

## HOT-MIX ASPHALT - NORTHBOUND (CONTINUED)

STATIONING		LENGTH					WIDTH				AREA					BITUMINOUS MATERIALS (TACK COAT)	POLYMERIZED HOT-MIX ASPHALT BINDER COURSE, IL-9.5FG, N90	POLYMERIZED HOT-MIX ASPHALT SURFACE COURSE, STONE MATRIX ASPHALT, 12.5, MIX "E", N80	HOT-MIX ASPHALT SURFACE COURSE, MIX "C", N 70	HOT-MIX ASPHALT BINDER COURSE, IL-19.0, N70	HOT-MIX ASPHALT SHOULDERS, 6 1/4"	HOT-MIX ASPHALT SHOULDERS, 8"	
		LEGNTH FEET	LEFT TURN LANE LENGTH FEET	RIGHT TURN LANE LENGTH FEET	OUTSIDE SHOULDER LENGTH FEET	INSIDE SHOULDER LENGTH FEET	LEFT TURN LANE WIDTH FEET	RIGHT TURN LANE WIDTH FEET	OUTSIDE SHOULDER WIDTH FEET	INSIDE SHOULDER WIDTH FEET	MAINLINE AREA SQ YD	LEFT TURN LANE AREA SQ YD	RIGHT TURN LANE AREA SQ YD	OUTSIDE SHOULDER AREA SQ YD	INSIDE SHOULDER AREA SQ YD								TOTAL SHOULDER AREA SQ YD
428+50	430+12	162	-	-	162	162	-	-	10	6	432.0	-	-	180.0	108.0	288.0	486.0	42.3	56.2	32.3	28.2	450.2	54.0
430+12	432+42	230	230	-	230	230	0-12	-	10	4	613.3	153.3	-	255.6	102.2	357.8	759.0	75.1	99.7	40.1	35.1	102.2	76.7
432+42	434+48	206	206	-	206	206	12	-	10	4	549.3	274.7	-	228.9	91.6	320.4	772.5	80.8	107.1	35.9	31.4	91.6	0.0
434+48	436+79	231	-	-	231	109	-	-	10	6-4	616.0	-	-	256.7	60.6	317.2	629.9	60.4	80.1	35.5	31.1	102.7	0.0
436+79	467+30.956	3051.96	-	-	3052	3052	-	-	10	6	8,138.5	-	-	3,391.1	2,034.6	5,425.7	9,155.9	797.6	1,058.0	607.7	531.7	1356.4	1017.3
STATION EQUATION: STA. 467+30.96 (BK.) = STA. 1480+00.00 (AH.)																							
1480+00	1480+61	61	61	-	61	61	0-3.6	-	10	6-4	162.7	12.2	-	67.8	33.9	101.7	186.7	17.1	22.7	11.4	10.0	27.1	20.3
1480+61	1482+23	162	162	162	162	162	3.6-12	0-8.7	10-4	4	432.0	140.4	78.3	126.0	72.0	198.0	572.9	63.8	84.6	22.2	19.4	16.9	12.7
1482+23	1482+91	68	68	68	68	68	12	8.7-12	4	4	181.3	90.7	78.2	30.2	30.2	60.4	277.2	34.3	45.5	6.8	5.9		0.0
1482+91	1484+28	137	137	137	137	137	12	12	4	4	365.3	182.7	182.7	60.9	60.9	121.8	575.4	71.6	95.0	13.6	11.9		0.0
1484+28	1486+09	181	-	-	37	112	-	-	4	4-6	482.7	-	-	16.4	62.2	78.7	378.9	47.3	62.7	8.8	7.7		0.0
1486+09	1507+60	2151	-	-	2151	2151	-	-	10	6	5,736.0	-	-	2,390.0	1,434.0	3,824.0	6,453.0	562.1	745.7	428.3	374.8	956.0	717.0
1507+60	1509+90	230	230	-	230	230	0-12	-	10	6	613.3	153.3	-	255.6	153.3	408.9	793.5	75.1	99.7	45.8	40.1	102.2	76.7
1509+90	1511+95	205	205	-	205	205	12	-	10	6	546.7	273.3	-	227.8	136.7	364.4	799.5	80.4	106.6	40.8	35.7	91.1	0.0
1511+95	1512+60	65	-	-	65	50	-	-	10	6	173.3	-	-	72.2	33.3	105.6	188.3	17.0	22.5	11.8	10.3	28.9	0.0
1512+60	1513+12	52	52	-	52	52	6.0-0	-	10	6	138.7	17.3	-	57.8	34.7	92.4	167.7	15.3	20.3	10.4	9.1	23.1	17.3
1513+12	1535+03	2191	-	-	2191	2191	-	-	10	6	5,842.7	-	-	2,434.4	1,460.7	3,895.1	6,573.0	572.6	759.5	436.3	381.7	973.8	730.3
1535+03	1537+33	230	230	-	230	230	0-12	-	10	6	613.3	153.3	-	255.6	153.3	408.9	793.5	75.1	99.7	45.8	40.1	102.2	76.7
1537+33	1539+38	205	205	-	205	205	12	-	10	6	546.7	273.3	-	227.8	136.7	364.4	799.5	80.4	106.6	40.8	35.7	91.1	0.0
1539+38	1540+03	65	-	-	65	48	-	-	10	6	173.3	-	-	72.2	32.0	104.2	187.4	17.0	22.5	11.7	10.2	28.9	0.0
1540+03	1540+55	52	52	-	52	52	6.0-0	-	10	6	138.7	17.3	-	57.8	34.7	92.4	167.7	15.3	20.3	10.4	9.1	23.1	17.3
1540+55	1577+78	3723	-	-	3723	3723	-	-	10	6	9,928.0	-	-	4,136.7	2,482.0	6,618.7	11,169.0	972.9	1,290.6	741.3	648.6	1514.2	1135.7
1577+78	1599+13	2135	-	-	2135	2135	-	-	-	6	5,693.3	-	-	-	1,423.3	1,423.3	4,803.8	557.9	740.1	159.4	139.5	152.4	711.7
1599+13	1706+07	10694	-	-	10694	10694	-	-	10	6	28,517.3	-	-	11,882.2	7,129.3	19,011.6	32,082.0	2,794.7	3,707.3	2,129.3	1,863.1	4752.9	3564.7
1706+07	1712+70	663	-	-	663	663	-	-	-	6	1,768.0	-	-	-	442.0	442.0	1,491.8	173.3	229.8	49.5	43.3	58.7	221.0
1712+70	1716+21	351	-	-	351	351	-	-	10	6	936.0	-	-	390.0	234.0	624.0	1,053.0	91.7	121.7	69.9	61.2	156.0	117.0
1716+21	1716+44	23	-	-	23	23	-	-	10	6	61.3	-	-	25.6	15.3	40.9	69.0	6.0	8.0	4.6	4.0	10.2	7.7
NORTHBOUND SUB-TOTAL 2 =																81,385.8	7,397.1	9,812.5	5,050.1	4,418.9	11,212.0	8,574.1	

NORTHBOUND SUB-TOTAL 1 =	60,504.6	5,506.3	7,304.3	3,746.3	3,278.0	8,367.6	5,729.1
NORTHBOUND SUB-TOTAL 2 =	81,385.8	7,397.1	9,812.5	5,050.1	4,418.9	11,212.0	8,574.1
NORTHBOUND TOTAL =	141,890.4	12,903.5	17,116.8	8,796.5	7,696.9	19,579.5	14,303.2

# SCHEDULE OF QUANTITIES

## HOT-MIX ASPHALT - SOUTHBOUND

STATIONING		LENGTH					WIDTH				AREA					BITUMINOUS MATERIALS (TACK COAT)	POLYMERIZED HOT-MIX ASPHALT BINDER COURSE, IL-9.5FG, N90	POLYMERIZED HOT-MIX ASPHALT SURFACE COURSE, STONE MATRIX ASPHALT, 12.5, MIX "E", N80	HOT-MIX ASPHALT SURFACE COURSE, MIX "C", N 70	HOT-MIX ASPHALT BINDER COURSE, IL-19.0, N70	HOT-MIX ASPHALT SHOULDERS, 6 1/4"	HOT-MIX ASPHALT SHOULDERS, 8"	
		LEGNTH FEET	LEFT TURN LANE	RIGHT TURN LANE	OUTSIDE SHOULDER	INSIDE SHOULDER	LEFT TURN LANE	RIGHT TURN LANE	OUTSIDE SHOULDER	INSIDE SHOULDER	MAINLINE AREA SQ YD	LEFT TURN LANE	RIGHT TURN LANE	OUTSIDE SHOULDER	INSIDE SHOULDER								TOTAL SHOULDERS AREA SQ YD
			LENGTH FEET	LENGTH FEET	LENGTH FEET	LENGTH FEET	WIDTH FEET	WIDTH FEET	WIDTH FEET	WIDTH FEET		AREA SQ YD	AREA SQ YD	AREA SQ YD	AREA SQ YD								
212+84	213+07	23	-	-	23	23	-	-	10	6	61.3	-	-	25.6	15.3	40.9	69.0	6.0	8.0	4.6	4.0	10.2	7.7
213+07	217+86	479	-	-	479	479	-	-	10	6	1,277.3	-	-	532.2	319.3	851.6	1,437.0	125.2	166.1	95.4	83.5	212.9	159.7
217+86	219+71	185	-	-	185	100	-	-	10	6	493.3	-	-	205.6	66.7	272.2	516.8	48.3	64.1	30.5	26.7	82.2	0.0
219+71	222+42	271	271	-	271	271	12	-	10	6	722.7	361.3	-	301.1	180.7	481.8	1,056.9	106.2	140.9	54.0	47.2	120.4	0.0
222+42	225+21	279	279	-	279	279	12-0	-	10	6	744.0	186.0	-	310.0	186.0	496.0	962.6	91.1	120.9	55.6	48.6	124.0	93.0
225+21	247+60	2239	-	-	2239	2239	-	-	10	6	5,970.7	-	-	2,487.8	1,492.7	3,980.4	6,717.0	585.1	776.2	445.8	390.1	995.1	746.3
247+60	248+07	47	47	-	47	50	0-5.4	-	10	6	125.3	14.1	-	52.2	33.3	85.6	151.9	13.7	18.1	9.6	8.4	20.9	15.7
248+07	248+73	66	-	-	66	66	-	-	10	6	176.0	-	-	73.3	44.0	117.3	198.0	17.2	22.9	13.1	11.5	29.3	0.0
248+73	250+80	207	207	-	207	207	12	-	10	6	552.0	276.0	-	230.0	138.0	368.0	807.3	81.1	107.6	41.2	36.1	92.0	0.0
250+80	253+09	229	229	-	229	229	12-0	-	10	6	610.7	152.7	-	254.4	152.7	407.1	790.1	74.8	99.2	45.6	39.9	101.8	76.3
253+09	273+25	2016	-	-	2016	2016	-	-	10	6	5,376.0	-	-	2,240.0	1,344.0	3,584.0	6,048.0	526.8	698.9	401.4	351.2	896.0	672.0
273+25	274+25	100	-	-	-	35	-	-	-	4	266.7	-	-	-	15.6	15.6	190.5	26.1	34.7	1.7	1.5	-	0.0
274+25	275+24	99	99	99	99	99	35.7-12	12	4	4	264.0	262.4	132.0	44.0	44.0	88.0	503.8	64.5	85.6	9.9	8.6	-	0.0
275+24	276+30	106	106	106	106	106	12	12	4	4	282.7	141.3	141.3	47.1	47.1	94.2	445.2	55.4	73.5	10.6	9.2	-	0.0
276+30	277+31	101	101	101	101	101	12	12-7.2	4	4	269.3	134.7	107.7	44.9	44.9	89.8	406.0	50.1	66.5	10.1	8.8	-	0.0
277+31	278+62	131	131	131	131	131	12-4.8	7.2-0	10-4	4	349.3	122.3	40.4	101.9	58.2	160.1	453.7	50.2	66.6	17.9	15.7	24.9	18.7
278+62	279+12	50	50	-	50	50	4.8-2.2	-	10	4	133.3	19.4	-	55.6	22.2	77.8	155.6	15.0	19.9	8.7	7.6	22.2	16.7
279+12	279+35	23	23	-	23	23	2.2-1.5	-	10	6-4	61.3	4.7	-	25.6	12.8	38.3	70.5	6.5	8.6	4.3	3.8	10.2	7.7
PAVING OMISSION S.N. 058-0125																							
280+84	282+36	152	-	-	152	152	-	-	10	6	405.3	-	-	168.9	101.3	270.2	456.0	39.7	52.7	30.3	26.5	67.6	50.7
282+36	282+59	23	-	-	23	23	-	-	10	6	61.3	-	-	25.6	15.3	40.9	69.0	6.0	8.0	4.6	4.0	10.2	7.7
282+59	300+03	1744	-	-	1744	1744	-	-	10	6	4,650.7	-	-	1,937.8	1,162.7	3,100.4	5,232.0	455.8	604.6	347.2	303.8	775.1	581.3
300+03	300+50	47	47	-	47	47	0-5.4	-	10	6	125.3	14.1	-	52.2	31.3	83.6	150.5	13.7	18.1	9.4	8.2	20.9	15.7
300+50	301+15	65	-	-	65	50	-	-	10	6	173.3	-	-	72.2	33.3	105.6	188.3	17.0	22.5	11.8	10.3	28.9	0.0
301+15	303+22	207	207	-	207	207	12	-	10	6	552.0	276.0	-	230.0	138.0	368.0	807.3	81.1	107.6	41.2	36.1	92.0	0.0
303+22	305+52	230	230	-	230	230	12-0	-	10	6	613.3	153.3	-	255.6	153.3	408.9	793.5	75.1	99.7	45.8	40.1	102.2	76.7
305+52	332+12	2660	-	-	2660	2660	-	-	10	6	7,093.3	-	-	2,955.6	1,773.3	4,728.9	7,980.0	695.1	922.1	529.6	463.4	1182.2	886.7
332+12	332+58	46	46	-	46	46	0-5.4	-	10	6	122.7	13.8	-	51.1	30.7	81.8	147.3	13.4	17.7	9.2	8.0	20.4	15.3
332+58	333+24	66	-	-	66	50	-	-	10	6	176.0	-	-	73.3	33.3	106.7	190.8	17.2	22.9	11.9	10.5	29.3	0.0
333+24	335+31	207	207	-	207	207	12	-	10	6	552.0	276.0	-	230.0	138.0	368.0	807.3	81.1	107.6	41.2	36.1	92.0	0.0
335+31	337+61	230	230	-	230	230	12-0	-	10	6	613.3	153.3	-	255.6	153.3	408.9	793.5	75.1	99.7	45.8	40.1	102.2	76.7
337+61	359+06	2145	-	-	2145	2145	-	-	10	6	5,720.0	-	-	2,383.3	1,430.0	3,813.3	6,435.0	560.6	743.6	427.1	373.7	953.3	715.0
359+06	359+72	66	66	-	66	66	0-25.3	-	10-8	6-4	176.0	92.8	-	66.0	36.7	102.7	250.7	26.3	34.9	11.5	10.1	29.3	22.0
359+72	360+99	127	-	-	50	14	-	-	8	4	338.7	-	-	44.4	6.2	50.7	262.8	33.2	44.0	5.7	5.0	-	0.0
360+99	363+26	227	227	227	175	227	12	12	8	4	605.3	302.7	302.7	155.6	100.9	256.4	990.3	118.6	157.4	28.7	25.1	-	0.0
363+26	363+32	6	6	6	6	6	12	12-11.7	8	4	16.0	8.0	7.9	5.3	2.7	8.0	26.9	3.1	4.1	0.9	0.8	2.7	0.0
363+32	365+56	224	224	224	224	224	12-.3	11.7-0	8	4	597.3	153.1	145.6	199.1	99.6	298.7	806.4	87.8	116.5	33.5	29.3	17.3	13.0
365+56	365+61	5	5	-	5	5	.3-0	-	10	6	13.3	0.1	-	5.6	3.3	8.9	15.1	1.3	1.7	1.0	0.9	2.2	1.7
365+61	391+40	2579	-	-	2579	2579	-	-	10	6	6,877.3	-	-	2,865.6	1,719.3	4,584.9	7,737.0	674.0	894.1	513.5	449.3	1146.2	859.7
391+40	391+86	46	46	-	46	46	0-5.4	-	10	6	122.7	13.8	-	51.1	30.7	81.8	147.3	13.4	17.7	9.2	8.0	20.4	15.3
391+86	392+51	65	-	-	65	50	-	-	10	6	173.3	-	-	72.2	33.3	105.6	188.3	17.0	22.5	11.8	10.3	28.9	0.0
392+51	394+58	207	207	-	207	207	12	-	10	6	552.0	276.0	-	230.0	138.0	368.0	807.3	81.1	107.6	41.2	36.1	92.0	0.0
394+58	396+86	228	228	-	228	228	12-0	-	10	6	608.0	152.0	-	253.3	152.0	405.3	786.6	74.5	98.8	45.4	39.7	101.3	76.0
396+86	409+00	1214	-	-	1214	1214	-	-	10	6	3,237.3	-	-	1,348.9	809.3	2,158.2	3,642.0	317.3	420.9	241.7	211.5	924.4	404.7
SOUTHBOUND SUB-TOTAL 1 =																	60,690.8	5,522.2	7,325.4	3,759.0	3,289.2	8,583.6	5,632.0

# SCHEDULE OF QUANTITIES

## HOT-MIX ASPHALT - SOUTHBOUND (CONTINUED)

STATIONING		LENGTH					WIDTH				AREA					BITUMINOUS MATERIALS (TACK COAT)	POLYMERIZED HOT-MIX ASPHALT BINDER COURSE, IL-9.5FG, N90	POLYMERIZED HOT-MIX ASPHALT SURFACE COURSE, STONE MATRIX ASPHALT, 12.5, MIX "E", N80	HOT-MIX ASPHALT SURFACE COURSE, MIX "C", N 70	HOT-MIX ASPHALT BINDER COURSE, IL-19.0, N70	HOT-MIX ASPHALT SHOULDERS, 6 1/4"	HOT-MIX ASPHALT SHOULDERS, 8"	
		LEGNTH FEET	LEFT TURN LANE	RIGHT TURN LANE	OUTSIDE SHOULDER	INSIDE SHOULDER	LEFT TURN LANE	RIGHT TURN LANE	OUTSIDE SHOULDER	INSIDE SHOULDER	MAINLINE AREA SQ YD	LEFT TURN LANE	RIGHT TURN LANE	OUTSIDE SHOULDER	INSIDE SHOULDER								TOTAL SHOULDERS AREA SQ YD
			LENGTH FEET	LENGTH FEET	LENGTH FEET	LENGTH FEET	WIDTH FEET	WIDTH FEET	WIDTH FEET	WIDTH FEET		AREA SQ YD	AREA SQ YD	AREA SQ YD	AREA SQ YD								
428+50	435+18	668	-	-	1034	668	-	-	10	6	1,781.3	-	-	1,148.9	445.3	1,594.2	2,278.5	174.6	231.6	178.6	156.2	459.6	222.7
435+18	436+53	135	-	-	-	40	-	-	-	6	360.0	-	-	-	26.7	26.7	261.0	35.3	46.8	3.0	2.6	-	0.0
436+53	437+37	84	84	84	84	84	36.8-0	12	8	6	224.0	171.7	112.0	74.7	56.0	130.7	430.9	49.8	66.0	14.6	12.8	-	0.0
437+37	438+25	88	-	88	88	88	-	12	8	6	234.7	-	117.3	78.2	58.7	136.9	330.0	34.5	45.8	15.3	13.4	-	29.3
438+25	440+54	229	-	229	229	229	-	12-0	8	6	610.7	-	152.7	203.6	152.7	356.2	755.7	74.8	99.2	39.9	34.9	16.9	12.7
440+54	467+30.956	2677	-	-	2677	2677	-	-	10	6	7,138.5	-	-	2,974.4	1,784.6	4,759.0	8,030.9	699.6	928.0	533.0	466.4	1189.8	892.3
STATION EQUATION: STA. 467+30.96 (BK.) = STA. 1480+00.00 (AH)																							
1480+00	1484+34	434	-	-	434	434	-	-	10	6	1,157.3	-	-	482.2	289.3	771.6	1,302.0	113.4	150.5	86.4	75.6	192.9	144.7
1484+34	1485+62	128	-	-	25	66	-	-	4	6-4	341.3	-	-	11.1	36.7	47.8	262.7	33.5	44.4	5.4	4.7	-	0.0
1485+62	1486+16	54	54	54	54	54	33-12	12	4	4	144.0	135.0	72.0	24.0	24.0	48.0	269.3	34.4	45.6	5.4	4.7	-	0.0
1486+16	1486+65	49	49	49	49	49	12	12	4	4	130.7	65.3	65.3	21.8	21.8	43.6	205.8	25.6	34.0	4.9	4.3	-	0.0
1486+65	1488+21	156	156	156	156	156	12	12-6.6	4	4	416.0	208.0	161.2	69.3	69.3	138.7	623.6	76.9	102.1	15.5	13.6	-	0.0
1488+21	1489+95	174	174	174	174	174	12-3	6.6-0	10-4	4	464.0	145.0	63.8	135.3	77.3	212.7	597.7	65.9	87.5	23.8	20.8	16.9	12.7
1489+95	1490+51	56	56	-	56	56	3-0	-	10	6-4	149.3	9.3	-	62.2	31.1	93.3	170.1	15.5	20.6	10.5	9.1	24.9	18.7
1490+51	1511+45	2094	-	-	2094	2094	-	-	10	6	5,584.0	-	-	2,326.7	1,396.0	3,722.7	6,282.0	547.2	725.9	416.9	364.8	930.7	698.0
1511+45	1511+96	51	51	-	51	51	0-6	-	10	6	136.0	17.0	-	56.7	34.0	90.7	164.5	15.0	19.9	10.2	8.9	22.7	17.0
1511+96	1512+62	66	-	-	66	50	-	-	10	6	176.0	-	-	73.3	33.3	106.7	190.8	17.2	22.9	11.9	10.5	29.3	0.0
1512+62	1514+67	205	205	-	205	205	12	-	10	6	546.7	273.3	-	227.8	136.7	364.4	799.5	80.4	106.6	40.8	35.7	91.1	0.0
1514+67	1516+97	230	230	-	230	230	12-0	-	10	6	613.3	460.0	-	255.6	153.3	408.9	1,000.5	105.2	139.5	45.8	40.1	102.2	79.7
1516+97	1538+88	2191	-	-	2191	2191	-	-	10	6	5,842.7	-	-	2,434.4	1,460.7	3,895.1	6,573.0	572.6	759.5	436.3	381.7	973.8	730.3
1538+88	1539+40	52	52	-	52	52	0-6	-	10	6	138.7	17.3	-	57.8	34.7	92.4	167.7	15.3	20.3	10.4	9.1	23.1	17.3
1539+40	1540+05	65	-	-	65	50	-	-	10	6	173.3	-	-	72.2	33.3	105.6	188.3	17.0	22.5	11.8	10.3	28.9	0.0
1540+05	154210	205	205	-	205	205	12	-	10	6	546.7	273.3	-	227.8	136.7	364.4	799.5	80.4	106.6	40.8	35.7	91.1	0.0
154210	154440	230	230	-	230	230	12-0	-	10	6	613.3	153.3	-	255.6	153.3	408.9	793.5	75.1	99.7	45.8	40.1	102.2	76.7
154440	157934	3494	-	-	3494	3494	-	-	10	6	9,317.3	-	-	3,882.2	2,329.3	6,211.6	10,482.0	913.1	1,211.3	695.7	608.7	1275.6	1164.7
157934	160711	2777	-	-	-	2777	-	-	-	6	7,405.3	-	-	-	1,851.3	1,851.3	6,248.3	725.7	962.7	207.3	181.4	727.1	925.7
160711	169823	9112	-	-	9112	9112	-	-	10	6	24,298.7	-	-	10,124.4	6,074.7	16,199.1	27,336.0	2,381.3	3,158.8	1,814.3	1,587.5	4026.7	3037.3
169823	171013	1190	-	-	-	1190	-	-	-	6	3,173.3	-	-	-	793.3	793.3	2,677.5	311.0	412.5	88.9	77.7	192.0	396.7
171013	171621	608	-	-	608	608	-	-	10	6	1,621.3	-	-	675.6	405.3	1,080.9	1,824.0	158.9	210.8	121.1	105.9	270.2	202.7
171621	171644	23	-	-	23	23	-	-	10	6	61.3	-	-	25.6	15.3	40.9	69.0	6.0	8.0	4.6	4.0	10.2	7.7
SOUTHBOUND SUB-TOTAL 2 =																81,114.1	7,455.1	9,889.5	4,938.8	4,321.4	10,797.8	8,686.9	

SOUTHBOUND SUB-TOTAL 1 =	60,690.8	5,522.2	7,325.4	3,759.0	3,289.2	8,583.6	5,632.0
SOUTHBOUND SUB-TOTAL 2 =	81,114.1	7,455.1	9,889.5	4,938.8	4,321.4	10,797.8	8,686.9
SOUTHBOUND TOTAL =	141,805.0	12,977.4	17,214.9	8,697.8	7,610.6	19,381.3	14,318.9

# SCHEDULE OF QUANTITIES

## HOT-MIX ASPHALT - RAMPS

STATIONING		LEGNTH FEET	LENGTH		WIDTH			AREA				BITUMINOUS MATERIALS (TACK COAT)	POLYMERIZED HOT-MIX ASPHALT BINDER COURSE, IL-9.5FG, N90	POLYMERIZED HOT-MIX ASPHALT SURFACE COURSE, STONE MATRIX ASPHALT, 12.5, MIX "E", N80	HOT-MIX ASPHALT SURFACE COURSE, MIX "C", N 70	HOT-MIX ASPHALT BINDER COURSE, IL-19.0, N70
			OUTSIDE SHOULDER LENGTH FEET	INSIDE SHOULDER LENGTH FEET	MAINLINE WIDTH FEET	OUTSIDE SHOULDER WIDTH FEET	INSIDE SHOULDER WIDTH FEET	RAMP AREA SQ YD	OUTSIDE SHOULDER AREA SQ YD	INSIDE SHOULDER AREA SQ YD	TOTAL SHOULDER AREA SQ YD					
FROM	TO															
RAMP E																
-3+67	0+00	367			0-13.4			273.2				184.4	26.8	35.5	0.0	0.0
0+00	3+00	300	300	-	13.4-24	10	-	623.3	333.3	-	333.3	645.8	61.1	81.0	37.3	32.7
3+00	17+92	1492	1492	-	24	10	-	3,978.7	1,657.8	-	1,657.8	3,804.6	389.9	517.2	185.7	162.5
17+92	21+35	343	343	343	24	10	0-18	914.7	381.1	343.0	724.1	1,106.2	89.6	118.9	81.1	71.0
21+35	24+08	273	273	273	24	10	6	728.0	303.3	182.0	485.3	819.0	71.3	94.6	54.4	47.6
24+08	24+23	15	15	15	24	10	6	40.0	16.7	10.0	26.7	45.0	3.9	5.2	3.0	2.6
RAMP E TOTAL =												6,604.9	642.7	852.5	361.4	316.3
RAMP F																
-7+33	0+00	733			0-13.4			545.7				368.3	53.5	70.9	0.0	0.0
0+00	6+00	600	600	-	13.4-24	10	-	1,246.7	666.7	-	666.7	1,291.5	122.2	162.1	74.7	65.3
6+00	16+00	1000	1000	-	24	10	-	2,666.7	1,111.1	-	1,111.1	2,550.0	261.3	346.7	124.4	108.9
16+00	27+77	1177	1177	1177	24	10	0-18	3,138.7	1,307.8	1,177.0	2,484.8	3,795.8	307.6	408.0	278.3	243.5
27+77	38+37	1060	1060	1060	24	10	6	2,826.7	1,177.8	706.7	1,884.4	3,180.0	277.0	367.5	211.1	184.7
38+37	38+52	15	15	15	24	10	6	40.0	16.7	10.0	26.7	45.0	3.9	5.2	3.0	2.6
RAMP F TOTAL =												11,230.7	1,025.5	1,360.4	691.5	605.0
RAMP D																
895+06	900+36	530	530	-	0-16	8	-	471.1	471.1	-	471.1	636.0	46.2	61.2	52.8	46.2
900+36	901+68	132	132	132	16	8	0-20	234.7	117.3	146.7	264.0	336.6	23.0	30.5	29.6	25.9
901+68	904+45	277	277	277	16	8	6	492.4	246.2	184.7	430.9	623.3	48.3	64.0	48.3	42.2
904+45	904+60	15	15	15	16	8	6	26.7	13.3	10.0	23.3	33.8	2.6	3.5	2.6	2.3
RAMP D TOTAL =												1,629.6	120.0	159.2	133.2	116.6
RAMP A																
216+80	216+95	15	15	15	16	8	6	26.7	13.3	10.0	23.3	33.8	2.6	3.5	2.6	2.3
216+95	221+21	426	426	426	16	8	0-20	757.3	378.7	473.3	852.0	1,086.3	74.2	98.5	95.4	83.5
221+21	228+72	751	751	-	0-16	8	-	667.6	667.6	-	667.6	901.2	65.4	86.8	74.8	65.4
RAMP A TOTAL =												2,021.3	142.3	188.7	172.8	151.2
RAMP TOTAL =												21,486.5	1,930.5	2,560.8	1,358.9	1,189.0

# SCHEDULE OF QUANTITIES

## HOT-MIX ASPHALT - CROSSOVERS

STATION	AREA SQ FT	AREA SQ YD	BITUMINOUS MATERIALS (TACK COAT)	HOT-MIX ASPHALT BINDER COURSE, IL-19.0, N70	HOT-MIX ASPHALT SURFACE COURSE, MIX "C", N 70
			40600290 POUND	40603085 TONS	40604052 TON
219+14	6521.7	724.6	489.1	71.0	81.2
248+39	1846.3	205.1	138.5	20.1	23.0
273+91	4236.8	470.8	317.8	46.1	52.7
300+82	1818.2	202.0	136.4	19.8	22.6
332+90	1844.9	205.0	138.4	20.1	23.0
360+35	3377.6	375.3	253.3	36.8	42.0
392+18	1832.8	203.6	137.5	20.0	22.8
435+94	6567.0	729.7	492.5	71.5	81.7
1485+22	2787.0	309.7	209.0	30.4	34.7
1512+28	1694.8	188.3	127.1	60.2	21.1
1539+71	1677.4	186.4	125.8	18.5	20.9
CROSSOVERS TOTAL =			2,565.3	414.4	425.7

## HOT-MIX ASPHALT SUMMARY

LOCATION	BITUMINOUS MATERIALS (TACK COAT)	POLYMERIZED HOT-MIX ASPHALT BINDER COURSE, IL-9.5FG, N90	POLYMERIZED HOT-MIX ASPHALT SURFACE COURSE, STONE MATRIX ASPHALT, 12.5, MIX "E", N80	HOT-MIX ASPHALT SURFACE COURSE, MIX "C", N 70	HOT-MIX ASPHALT BINDER COURSE, IL-19.0, N70	HOT-MIX ASPHALT SHOULDERS, 6 1/4"	HOT-MIX ASPHALT SHOULDERS, 8"
	40600290 POUND	40603219 TON	40605034 TONS	40604052 TON	40603085 TONS	48203022 SQ YD	48203029 SQ YD
NORTHBOUND	141,890.4	12,903.5	17,116.8	8,796.5	7,696.9	19,579.5	14303.2
SOUTHBOUND	141,805.0	12,977.4	17,214.9	8,697.8	7,610.6	19,381.3	14318.9
RAMPS	21,486.5	1,930.5	2,560.8	1,358.9	1,189.0	-	-
CROSSOVERS	2,565.3	-	-	425.7	414.4	-	-
PRAS	2,727.4	-	-	-	-	-	-
TOTAL	310,474.6	27,811.3	36,892.6	19,278.9	16,911.0	38,960.8	28,622.1
ROUND TO	310,475.0	27,812.0	36,893.0	19,279.0	16,911.0	38,961.0	28,623.0

## LONGITUDINAL PARTIAL DEPTH PATCHING

STATIONING		LANE	LENGTH FEET	PATCHING WIDTH FOOT	AVE THICK INCH	LONGITUDINAL PARTIAL DEPTH REMOVAL, 5"	LONGITUDINAL PARTIAL DEPTH PATCHING
FROM	TO					44050217.00 FOOT	44209000 TON
212+84.00	279+58.00	NBDL	13,348.0	2.0	5.0	13,348.0	830.5
280+08.00	409+00.00	NBDL	25,784.0	2.0	5.0	25,784.0	1,604.3
428+50.00	467+30.96	NBDL	7,761.9	2.0	5.0	7,761.9	483.0
212+84.00	279+58.00	NBPL	13,348.0	2.0	5.0	13,348.0	830.5
280+08.00	409+00.00	NBPL	25,784.0	2.0	5.0	25,784.0	1,604.3
428+50.00	467+30.96	NBPL	7,761.9	2.0	5.0	7,761.9	483.0
212+84.00	279+35.00	SBDL	13,302.0	2.0	5.0	13,302.0	827.7
280+84.00	409+00.00	SBDL	25,632.0	2.0	5.0	25,632.0	1,594.9
428+50.00	467+30.96	SBDL	7,761.9	2.0	5.0	7,761.9	483.0
212+84.00	279+35.00	SBPL	13,302.0	2.0	5.0	13,302.0	827.7
280+84.00	409+00.00	SBPL	25,632.0	2.0	5.0	25,632.0	1,594.9
428+50.00	467+30.96	SBPL	7,761.9	2.0	5.0	7,761.9	483.0
TOTAL						187,179.7	11,646.7
ROUND TO						187,180.0	11,647.0

# SCHEDULE OF QUANTITIES

## THERMOPLASTIC PAVMENT MARKING - LINE 4''

### US 51 NORTHBOUND

STATIONING		LOCATION	DESC.	LT/RT/CL	LENGTH (FEET)	THERMOPLASTIC PAVEMENT MARKING - LINE 4'' (FOOT)		GROOVING FOR RECESSED PAVEMENT MARKING - 5'' (FOOT)
						WHITE	YELLOW	
NORTHBOUND DRIVING LANE								
212+84.00	269+23.00	NBDL	EL	RT	5639.0	5639.0		5639.0
269+23.00	273+32.00	NBDL RTL	EL	RT	409.0	409.0		409.0
275+26.00	279+62.00	NBDL	EL	RT	436.0	436.0		436.0
PAVING OMISSION S. N. 058-0125								
281+12.00	359+17.00	NBDL	EL	RT	7805.0	7805.0		7805.0
361+19.00	409+00.00	NBDL	EL	RT	4781.0	4781.0		4781.0
J-TURN OMISSION								
428+50.00	467+30.96	NBDL	EL	RT	3881.0	3881.0		3881.0
STA. EQ.: STA. 467+30.96 (BK.) = STA. 1480+00.00 (AH.)								
1480+00.00	1480+61.00	NBDL	EL	RT	61.0	61.0		61.0
1480+61.00	1484+65.00	NBDL	EL	RT	404.0	404.0		404.0
1486+54.00	1574+11.00	NBDL	EL	RT	8757.0	8757.0		8757.0
1574+11.00	1577+77.00	RAMP E	RAMP DD	RT	366.0	91.5		91.5
1574+11.00	1577+77.00	RAMP E	EL	RT	366.0	366.0		366.0
00+00.00	24+23.00	RAMP E	EL	RT	2423.0	2423.0		2423.0
1602+52.00	1706+07.00	NBDL	EL	RT	10355.0	10355.0		10355.0
895+06.00	898+11.00	RAMP D	RAMP DD	LT	305.0	76.3		76.3
895+06.00	904+60.00	RAMP D	EL	RT	954.0	954.0		954.0
901+68.00	904+60.00	RAMP D	EL	LT	292.0		292.0	292.0
1712+68.00	1716+44.00	NBDL	EL	RT	376.0	376.0		376.0
NORTHBOUND PASSING LANE								
212+84.00	213+07.00	NBPL	EL	RT	23.0		23.0	23.0
213+07.00	218+57.00	NBPL SHLD	EL	RT	550.0		550.0	550.0
213+07.00	243+69.00	NBPL	EL	RT	3062.0		3062.0	3062.0
243+69.00	248+05.00	NBPL SHLD	EL	RT	436.0		436.0	436.0
243+69.00	268+21.00	NBPL	EL	RT	2452.0		2452.0	2452.0
268+21.00	272+58.00	NBPL LTL	EL	RT	437.0		437.0	437.0

STATIONING		LOCATION	DESC.	LT/RT/CL	LENGTH (FEET)	THERMOPLASTIC PAVEMENT MARKING - LINE 4'' (FOOT)		GROOVING FOR RECESSED PAVEMENT MARKING - 5'' (FOOT)
						WHITE	YELLOW	
274+84.00	279+54.00	NBPL	EL	RT	470.0		470.0	470.0
PAVING OMISSION S. N. 058-0125								
281+04.00	296+12.00	NBPL	EL	RT	1508.0		1508.0	1508.0
296+12.00	300+48.00	NBPL SHLD	EL	RT	436.0		436.0	436.0
296+12.00	328+20.00	NBPL	EL	RT	3208.0		3208.0	3208.0
328+20.00	332+56.00	NBPL SHLD	EL	RT	436.0		436.0	436.0
328+20.00	355+08.00	NBPL	EL	RT	2688.0		2688.0	2688.0
355+08.00	359+44.00	NBPL LTL	EL	RT	436.0		436.0	436.0
361+61.00	387+47.00	NBPL	EL	RT	2586.0		2586.0	2586.0
387+47.00	391+83.00	NBPL SHLD	EL	RT	436.0		436.0	436.0
387+47.00	409+00.00	NBPL	EL	RT	2153.0		2153.0	2153.0
J-TURN OMISSION								
428+50.00	430+12.00	NBPL	EL	RT	162.0		162.0	162.0
430+12.00	434+48.00	NBPL LTL	EL	RT	436.0		436.0	436.0
436+79.00	467+30.96	NBPL	EL	RT	3052.0		3052.0	3052.0
STATION EQUATION: STA. 467+30.96 (BK.) = STA. 1480+00.00 (AH.)								
1480+00.00	1484+28.00	NBPL LTL	EL	RT	428.0		428.0	428.0
1486+09.00	1507+60.00	NBPL	EL	RT	2151.0		2151.0	2151.0
1507+60.00	1511+95.00	NBPL SHLD	EL	RT	435.0		435.0	435.0
1507+60.00	1535+03.00	NBPL	EL	RT	2743.0		2743.0	2743.0
1535+03.00	1539+38.00	NBPL SHLD	EL	RT	435.0		435.0	435.0
1535+03.00	1716+44.00	NBPL	EL	RT	18141.0		18141.0	18141.0
US 51 NB SUBTOTAL =						46814.7	49592.0	96406.7

EL = EDGE LINE  
LL = LANE LINE  
DD = DOTTED DASH



# SCHEDULE OF QUANTITIES

## THERMOPLASTIC PAVMENT MARKING - LINE 4''

### US 51 SOUTHBOUND

STATIONING		LOCATION	DESC.	LT/RT/CL	LENGTH (FEET)	THERMOPLASTIC PAVEMENT MARKING - LINE 4'' (FOOT)		GROOVING FOR RECESSED PAVEMENT MARKING - 5'' (FOOT)
						WHITE	YELLOW	
SOUTHBOUND DRIVING LANE								
212+84.00	272+66.00	SBDL	EL	LT	5982.0	5982.0		5982.0
274+44.00	278+62.00	SBDL RTL	EL	LT	418.0	418.0		418.0
278+62.00	279+31.00	SBDL	EL	LT	69.0	69.0		69.0
PAVING OMISSION S. N. 058-0125								
280+80.00	359+53.00	SBDL	EL	LT	7873.0	7873.0		7873.0
361+50.00	365+56.00	SBDL RTL	EL	LT	406.0	406.0		406.0
365+56.00	409+00.00	SBDL	EL	LT	4344.0	4344.0		4344.0
J-TURN OMISSION								
428+50.00	434+50.00	SBDL	EL	LT	600.0	600.0		600.0
436+48.00	440+54.00	SBDL RTL	EL	LT	406.0	406.0		406.0
440+54.00	467+31.00	SBDL	EL	LT	2677.0	2677.0		2677.0
STA. EQ.: STA. 467+30.96 (BK.) = STA. 1480+00.00 (AH.)								
1480+00.00	1483+88.00	SBDL	EL	LT	388.0	388.0		388.0
1485+82.00	1489+95.00	SBDL RTL	EL	LT	413.0	413.0		413.0
1489+95.00	1572+01.00	SBDL	EL	LT	8206.0	8206.0		8206.0
1572+01.00	1579+34.00	RAMP F	EL	LT	733.0	733.0		733.0
00+00.00	38+52.00	RAMP F	EL	LT	3852.0	3852.0		3852.0
1618+14.00	1698+23.00	SBDL	EL	LT	8009.0	8009.0		8009.0
228+72.00	216+80.00	RAMP A	EL	LT	1192.0	1192.0		1192.0
228+72.00	221+21.00	RAMP A	RAMP DD	LT	751.0	187.8		187.8
1710+13.00	1716+44.00	SBDL	EL	LT	631.0	631.0		631.0
SOUTHBOUND PASSING LANE								
212+84.00	225+21.00	SBPL	EL	LT	1237.0	1237.0		1237.0
217+86.00	218+57.00	RADIUS	EL	LT	100.0	100.0		100.0
219+71.00	220+42.00	RADIUS	EL	LT	100.0	100.0		100.0
219+71.00	225+21.00	SBPL LTL	EL	LT	550.0	550.0		550.0
225+21.00	253+09.00	SBPL	EL	LT	2788.0	2788.0		2788.0
247+60.00	248+05.00	RADIUS	EL	LT	97.0	97.0		97.0
248+73.00	249+17.00	RADIUS	EL	LT	96.0	96.0		96.0
248+73.00	253+09.00	SBPL LTL	EL	LT	436.0	436.0		436.0
253+09.00	273+02.00	SBPL	EL	LT	1993.0	1993.0		1993.0
272+58.00	273+02.00	RADIUS	EL	LT	114.0	114.0		114.0
274+84.00	275+24.00	RADIUS	EL	LT	115.0	115.0		115.0
275+24.00	279+39.00	SBPL LTL	EL	LT	415.0	415.0		415.0
PAVING OMISSION S. N. 058-0125								
280+87.00	305+52.00	SBPL	EL	LT	2465.0	2465.0		2465.0
300+03.00	300+48.00	RADIUS	EL	LT	96.0	96.0		96.0
301+15.00	301+60.00	RADIUS	EL	LT	96.0	96.0		96.0

STATIONING		LOCATION	DESC.	LT/RT/CL	LENGTH (FEET)	THERMOPLASTIC PAVEMENT MARKING - LINE 4'' (FOOT)		GROOVING FOR RECESSED PAVEMENT MARKING - 5'' (FOOT)
						WHITE	YELLOW	
301+15.00	305+52.00	SBPL LTL	LL	LT	437.0		437.0	437.0
305+52.00	337+61.00	SBPL	LL	LT	3209.0		3209.0	3209.0
332+12.00	332+56.00	RADIUS	EL	LT	97.0		97.0	97.0
333+24.00	333+69.00	RADIUS	EL	LT	96.0		96.0	96.0
333+24.00	337+61.00	SBPL LTL	EL	LT	437.0		437.0	437.0
337+61.00	359+06.00	SBPL	EL	LT	2145.0		2145.0	2145.0
359+06.00	359+44.00	RADIUS	EL	LT	112.0		112.0	112.0
361+26.00	361+61.00	RADIUS	EL	LT	111.0		111.0	111.0
361+26.00	365+61.00	SBPL LTL	LL	LT	435.0		435.0	435.0
365+61.00	396+86.00	SBPL	EL	LT	3125.0		3125.0	3125.0
391+40.00	391+83.00	RADIUS	EL	LT	95.0		95.0	95.0
392+51.00	392+95.00	RADIUS	EL	LT	95.0		95.0	95.0
392+51.00	396+86.00	SBPL LTL	EL	LT	435.0		435.0	435.0
396+86.00	409+00.00	SBPL	EL	LT	1214.0		1214.0	1214.0
J-TURN OMISSION								
428+50.00	435+18.00	SBPL	EL	LT	668.0		668.0	668.0
435+18.00	437+37.00	SBPL LLEXT	DD	LT	219.0		54.8	54.8
434+48.00	435+18.00	RADIUS	EL	LT	95.0		95.0	95.0
436+79.00	437+37.00	RADIUS	EL	LT	131.0		131.0	131.0
437+37.00	467+30.96	SBPL	EL	LT	2994.0		2994.0	2994.0
STA. EQ.: STA. 467+30.96 (BK.) = STA. 1480+00.00 (AH.)								
1480+00.00	1484+34.00	SBPL	EL	LT	434.0		434.0	434.0
1484+34.00	1484+28.00	RADIUS	EL	LT	113.0		113.0	113.0
1486+09.00	1486+16.00	RADIUS	EL	LT	113.0		113.0	113.0
1486+16.00	1490+51.00	SBPL LTL	EL	LT	435.0		435.0	435.0
1490+51.00	1516+97.00	SBPL	EL	LT	2646.0		2646.0	2646.0
1511+45.00	1511+95.00	RADIUS	EL	LT	101.0		101.0	101.0
1512+62.00	1513+12.00	RADIUS	EL	LT	105.0		105.0	105.0
1512+62.00	1516+97.00	SBPL LTL	EL	LT	435.0		435.0	435.0
1516+97.00	1544+40.00	SBPL	EL	LT	2743.0		2743.0	2743.0
1538+88.00	1539+38.00	RADIUS	EL	LT	104.0		104.0	104.0
1540+05.00	1540+55.00	RADIUS	EL	LT	100.0		100.0	100.0
1540+05.00	1544+40.00	SBPL LTL	EL	LT	435.0		435.0	435.0
1544+40.00	1716+44.00	SBPL	EL	LT	17204.0		17204.0	17204.0
US 51 SB SUBTOTAL =						46386.8	51651.7	98038.5
US 51 TOTALS =						93201.5	101243.7	-
US 51 GRAND TOTAL =						194445.1		194445.1
ROUND TO =						194450		194450

EL = EDGE LINE  
LL = LANE LINE  
DD = DOTTED DASH

# SCHEDULE OF QUANTITIES

## THERMOPLASTIC PAVEMENT MARKING - LINE 6''

STATIONING		LOCATION	DESC.	LT/RT/CL	LENGTH (FEET)	THERMOPLASTIC PAVEMENT MARKING - LINE 6''	GROOVING FOR RECESSED PAVEMENT MARKING - 7''
						(FOOT)	(FOOT)
NORTHBOUND							
271+53.00	273+59.00	NBDL RTL	EL	RT	206.0	206.0	206.0
357+37.00	359+48.00	NBDL RTL	EL	RT	211.0	211.0	211.0
1482+91.00	1484+94.00	NBDL RTL	EL	RT	203.0	203.0	203.0
270+51.00	273+25.00	NBPL LTL	LL	RT	274.0	274.0	274.0
357+38.00	359+68.00	NBPL LTL	LL	RT	230.0	230.0	230.0
415+77.00	418+12.00	NBPL LTL	LL	RT	235.0	235.0	235.0
432+42.00	434+79.00	NBPL LTL	LL	RT	237.0	237.0	237.0
1482+23.00	1484+54.00	NBPL LTL	EL	RT	231.0	231.0	231.0
273+76.00	274+84.00	NBPL LLEXT	LL	RT	108.0	27.0	27.0
360+08.00	361+61.00	NBPL LLEXT	LL	RT	153.0	38.3	38.3
418+61.00	418+93.00	NBPL LLEXT	LL	RT	32.0	8.0	8.0
434+79.00	436+79.00	NBPL LLEXT	LL	RT	200.0	50.0	50.0
1485+06.00	1486+09.00	NBPL LLEXT	LL	RT	103.0	25.8	25.8
US 51 NB SUBTOTAL =						1,976.0	1,976.0
SOUTHBOUND							
274+39.00	276+30.00	SBDL RTL	EL	LT	191.0	191.0	191.0
361+20.00	363+26.00	SBDL RTL	EL	LT	206.0	206.0	206.0
436+48.00	438+25.00	SBDL RTL	EL	LT	177.0	177.0	177.0
1485+55.00	1487+65.00	SBDL RTL	EL	LT	210.0	210.0	210.0
274+58.00	277+31.00	SBPL LTL	LL	LT	273.0	273.0	273.0
361+07.00	363+32.00	SBPL LTL	EL	LT	225.0	225.0	225.0
419+52.00	421+87.00	SBPL LTL	LL	LT	235.0	235.0	235.0
1485+89.00	1488+21.00	SBPL LTL	LL	LT	232.0	232.0	232.0
273+02.00	274+08.00	SBPL LLEXT	LL	LT	106.0	26.5	26.5
359+06.00	360+67.00	SBPL LLEXT	LL	LT	161.0	40.3	40.3
418+70.00	419+02.00	SBPL LLEXT	LL	LT	32.0	8.0	8.0
1484+34.00	1485+38.00	SBPL LLEXT	LL	LT	104.0	26.0	26.0
US 51 SB SUBTOTAL =						1849.8	1849.8
US 51 GRAND TOTAL =						3,825.8	3,825.8
ROUND TO =						3,826.0	3,826.0

## THERMOPLASTIC PAVEMENT MARKING - LINE 8''

INTERSECTIONS AND STATIONING		LANE	DESC.	LT/RT/CL	THERMOPLASTIC PAVEMENT MARKING - LINE 8''	GROOVING FOR RECESSED PAVEMENT MARKING 9''
					(FOOT)	(FOOT)
WALKER RD.		-	ISLAND	-	379	379
WALL ST. & WOODCOCK RD.		-	ISLAND	-	504	504
WALL ST.		-	ISLAND	-	-	-
GABRIEL RD.		-	ISLAND	-	373	373
1598+02.00	1602+52.00	NBDL	EL	RT	450	450
20+24.00	24+73.00	RAMP E	EL	LT	449	449
1709+13.00	1712+68.00	NBDL	EL	RT	355	355
898+11.00	901+68.00	RAMP D	EL	LT	357	357
1603+17.00	1618+19.00	SBDL	EL	LT	1,502	1,502
23+82.00	39+02.00	RAMP F	EL	RT	1,520	1,520
1705+81.00	1710+33.00	SBDL	EL	LT	452	452
216+80.00	221+21.00	RAMP A	EL	RT	441	441
TOTAL =					6,782	6,782

## THERMOPLASTIC PAVEMENT MARKING - LINE 12''

INTERSECTIONS AND STATIONING		LANE	DESC.	LT/RT/CL	THERMOPLASTIC PAVEMENT MARKING - LINE 12''	GROOVING FOR RECESSED PAVEMENT MARKING 13''
					(FOOT)	(FOOT)
WALKER RD.		-	ISLAND	-	100	100
WALL ST. & WOODCOCK RD.		-	ISLAND	-	264	264
WALL ST.		-	ISLAND	-	-	-
GABRIEL RD.		-	ISLAND	-	119	119
1598+02.00	1602+52.00	NB	GORE	RT	214	214
1603+17.00	1618+19.00	SB	GORE	LT	1,081	1,081
TOTAL =					1,778	1,778
ROUND TO =					2,000	2,000

# SCHEDULE OF QUANTITIES

## THERMOPLASTIC PAVEMENT MARKING - LINE 24"/LETTERS & SYMBOLS

INTERSECTION	THERMOPLASTIC PAVEMENT MARKING - LINE 24" (FOOT)	GROOVING FOR RECESSED PAVEMENT MARKING 25" (FOOT)	THERMOPLASTIC PAVEMENT MARKING - LETTERS AND SYMBOLS (SQ FT)	GROOVING FOR THERMOPLASTIC PAVEMENT MARKING, LETTERS, NUMBERS AND SYMBOLS (SQ FT)
WALKER RD.	27	27	125.0	125.0
WALL ST. & WOODCOCK RD.	30	30	125.0	125.0
WALL ST.	29	29	62.0	62.0
GABRIEL RD.	49	49	125.0	125.0
TOTAL =	135	135	437.0	437.0
ROUND TO =	160	160	437	437

## PREFORMED PLASTIC PAVEMENT MARKING - LINE 6"

STATIONING		LOCATION	DESC.	LT/RT/CL	LENGTH (FEET)	PREFORMED PLASTIC PAVEMENT MARKING - LINE 6" (FOOT)
FROM	TO					
212+84.00	279+58.00	NB LANES	CL SD	RT	6674.0	1668.5
OMISSION S. N. 058-0125						
281+08.00	409+00.00	NB LANES	CL SD	RT	12792.0	3198.0
J-TURN OMISSION						
428+50.00	467+30.96	NB LANES	CL SD	RT	3881.0	970.2
STA. EQ.: STA 467+30.96 (BK) = STA 1480+00 (AH)						
1480+00.00	1716+44.00	NB LANES	CL SD	RT	23644.0	5911.0
3+00.00	24+23.00	RAMP E	RAMP SD	RT	2123.0	530.8
					US 51 NB SUBTOTAL =	12278.5
212+84.00	279+35.00	SB LANES	CL SD	LT	6651.0	1662.8
PAVING OMISSION S. N. 058-0125						
280+84.00	409+00.00	SB LANES	CL SD	LT	12816.0	3204.0
J-TURN OMISSION						
428+50.00	467+30.96	SB LANES	CL SD	LT	3881.0	970.2
STA. EQ.: STA 467+30.96 (BK.) = STA 1480+00.00 (AH.)						
1480+00.00	1716+44.00	SB LANES	CL SD	LT	23644.0	5911.0
06+00.00	38+52.00	RAMP F	RAMP SD	LT	3252.0	813.0
					US 51 SB SUBTOTAL =	12561.0
					TOTAL =	24839.5
					ROUND TO =	24840

# SCHEDULE OF QUANTITIES

## GUARDRAIL

STATIONING		LOCATION	SIDE	STEEL PLATE BEAM GUARDRAIL, TYPE A 6 FOOT POSTS (FOOT)	TRAFFIC TERMINAL BARRIER, TYPE 1 (SPECIAL) TANGENT (EACH)	TRAFFIC BARRIER TERMINAL, TYPE 2 (EACH)	GUARDRAIL REFLECTORS, TYPE A (EACH)	TERMINAL MARKER - DIRECT APPLIED (EACH)
FROM	TO	NORTHBOUND						
1575+38.5	1577+38.5	US 51	RT	187.5	1	1	3	1
17+41	19+80	RAMP E	RT	225	1	1	4	1
TOTALS:				412.5	2	2	7	2

## AGGREGATE WEDGE SHOULDER, TYPE B

LOCATION	WIDTH (FEET)	WEDGE THICKNESS (INCH)	AGGREGATE WEDGE SHOULDER, TYPE B (TON)
NORTHBOUND DL	2.0	0.875	482.7
RAMP E	2.0	0.875	29.6
RAMP D	2.0	0.875	13.8
NORTHBOUND PL	2.0	0.875	509.1
SOUTHBOUND DL	2.0	0.875	471.0
RAMP F	2.0	0.875	50.2
RAMP A	2.0	0.875	13.3
SOUTHBOUND PL	2.0	0.875	509.2
TOTAL =			2,078.9
ROUND TO:			2,079.0

## PUBLIC ROAD APPROACHES

STATION	INTERSECTION	SURFACE REMOVAL, VARIABLE DEPTH (SPECIAL) (SQ YD)	INCIDENTAL HOT-MIX ASPHALT SURFACING (TON)	BITUMINOUS MATERIALS TACK COAT (POUND)
NORTHBOUND				
273+92	WALKER RD	398.7	33.5	269.1
360+35	WOODCOCK RD	663.6	55.7	447.9
1485+22	GABRIELLE RD	617.4	51.9	416.8
NB SUBTOTAL =		1,679.7	141.1	1,133.8
SOUTHBOUND				
273+92	WALKER RD	508.2	42.7	343.1
360+35	WALL ST	590.6	49.6	398.7
435+94	WALL ST	690.6	58.0	466.2
1485+22	GABRIELLE RD	571.5	48.0	385.8
SB SUBTOTAL =		2,360.9	198.3	1,593.6
PROJECT TOTAL =		4041	339	2,727.4





NOTE: TEMPORARY PAVEMENT MARKING - LINE 4" SHALL BE USED TO REPLACE THE EDGELINE AFTER THE COMPLETION OF PRE-STAGE CONSTRUCTION. THE LINE SHOULD BE OFFSET TO ALLOW FOR STAGE 1 CONSTRUCTION.

### PRE-STAGE CONSTRUCTION

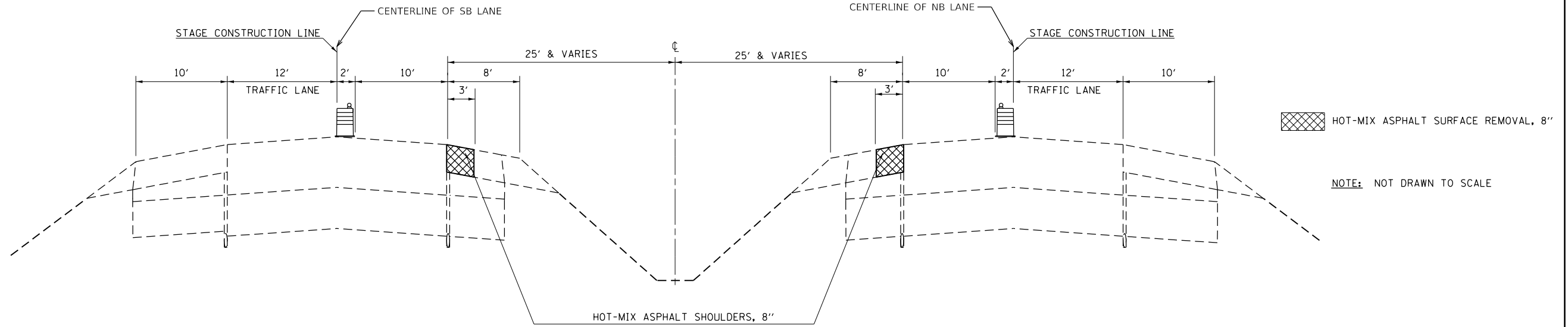

NOTE: PARTIAL REMOVAL OF THE EXISTING SUBBASE GRANULAR MATERIAL SHALL BE REQUIRED TO CONSTRUCT THE HOT-MIX ASPHALT SHOULDERS, 6 1/4". THE REMOVAL OF THE SUBBASE GRANULAR MATERIAL SHALL BE INCLUDED IN THE COST FOR PAVED SHOULDER REMOVAL, 6 1/4".

### STAGE 1 CONSTRUCTION

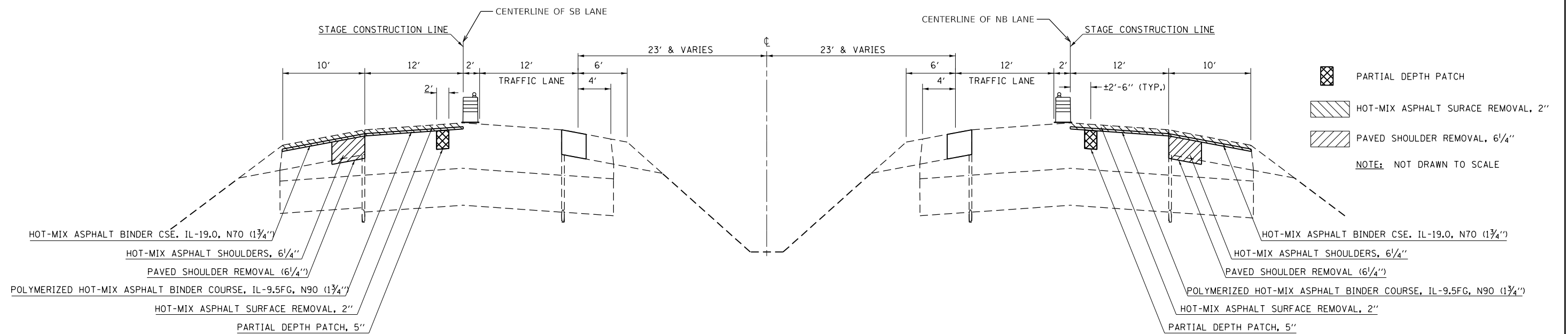

FILE NAME =	USER NAME = stefenmk	DESIGNED -	REVISED -	<b>STATE OF ILLINOIS DEPARTMENT OF TRANSPORTATION</b>	<b>STAGING TYPICAL CROSS SECTIONS</b>			F.A.P. RTE.	SECTION	COUNTY	TOTAL SHEETS	SHEET NO.			
pww\planroom.dot.illinois.gov\PWIDOT\Documents\DOT Offices\District 7\Projects\74779\CADData\CADsheets\DRAWN-sh1-details.dgn		CHECKED -	REVISED -		SCALE: N/A	SHEET 1	OF 2	SHEETS	STA.	TO STA.	322A	(46,47)RS-3, (58-20-1)RS-1	MACON	84	31
PLOT SCALE = 100.0000' / in.		DATE -	REVISED -		CONTRACT NO. 74779										
Default		PLOT DATE = 1/29/2020			ILLINOIS FED. AID PROJECT										

### STAGE 2 CONSTRUCTION

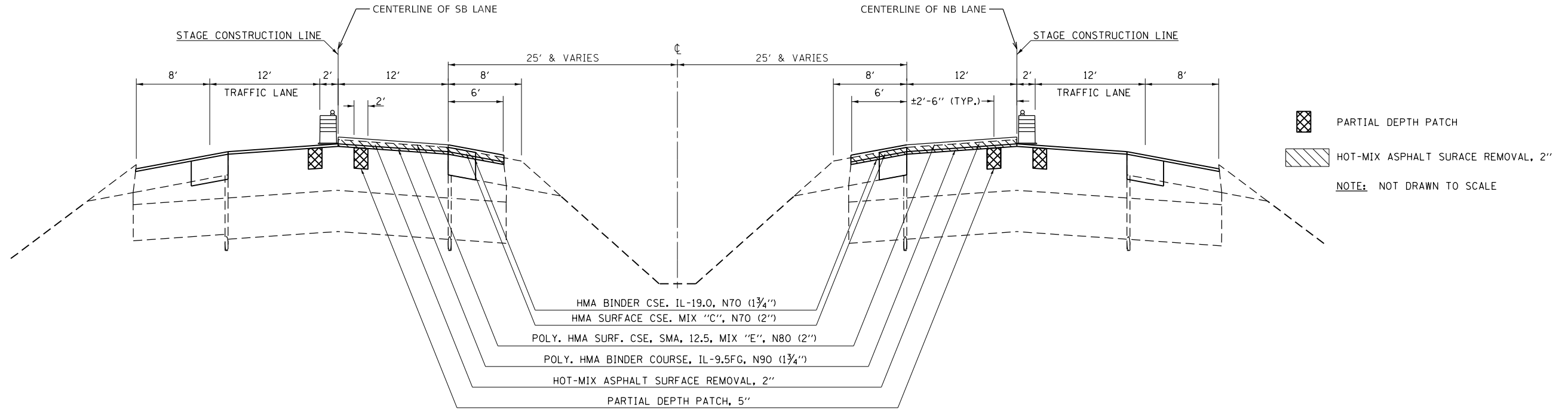

### STAGE 3 CONSTRUCTION

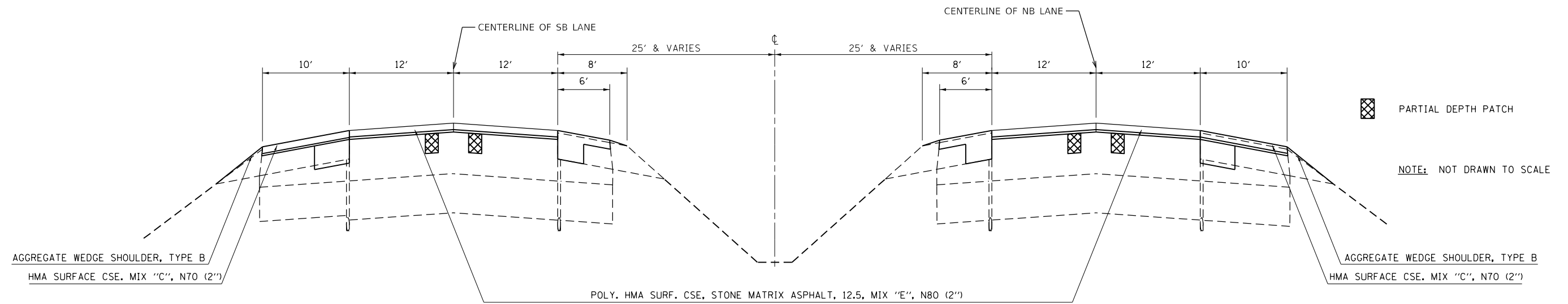

FILE NAME =	USER NAME = steffenmk	DESIGNED -	REVISED -	<b>STATE OF ILLINOIS DEPARTMENT OF TRANSPORTATION</b>	<b>STAGING TYPICAL CROSS SECTIONS</b>			F.A.P. RTE.	SECTION	COUNTY	TOTAL SHEETS	SHEET NO.			
pww\planroom.dot.illinois.gov\PWIDOT\Documents\DOT Offices\District 7\Projects\74779\CADDData\CADsheets\DRAWN-shi-details.dgn		CHECKED -	REVISED -		SCALE: N/A	SHEET 2	OF 2	SHEETS	STA.	TO STA.	322A	(46,47)RS-3, (58-20-1)RS-1	MACON	84	32
Default	PLOT SCALE = 100.0000' / in.	DATE -	REVISED -								CONTRACT NO. 74779				
	PLOT DATE = 1/29/2020										ILLINOIS FED. AID PROJECT				



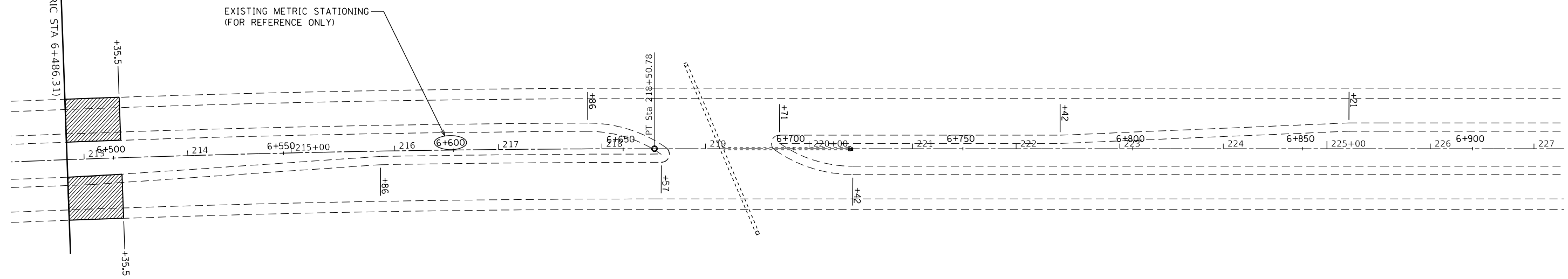

- HMA SURFACE REMOVAL - BUTT JOINT
- MILLING TRANSITION

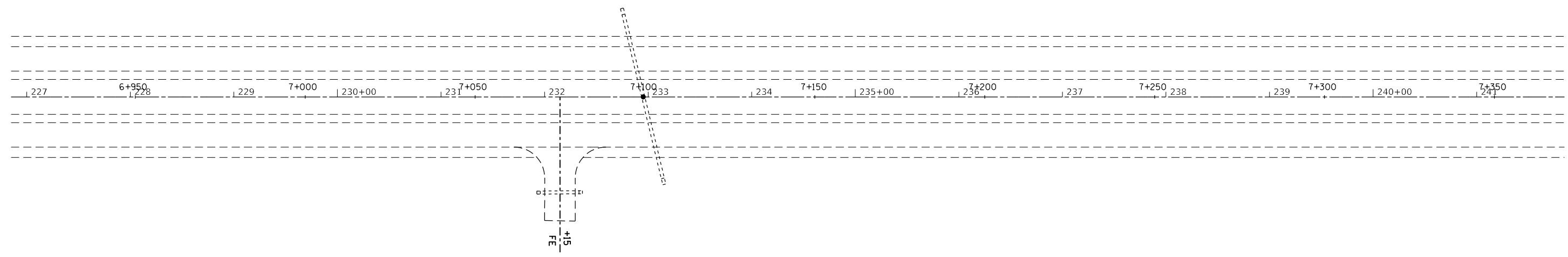

- HMA SURFACE REMOVAL - BUTT JOINT
- MILLING TRANSITION

FILE NAME =	USER NAME = steffemk	DESIGNED -	REVISED -
pww\planroom.dot\illinois.gov\PWIDOT\Documents\DOT Offices\District 7\Projects\74779\CADDData\CADsheets\DRAWN-shit-plan.dgn		DRAWN	REVISED -
Default	PLOT SCALE = 100.0000 ' / in.	CHECKED -	REVISED -
	PLOT DATE = 1/29/2020	DATE -	REVISED -

**STATE OF ILLINOIS  
DEPARTMENT OF TRANSPORTATION**

**PLAN SHEET**

SCALE: 1" = 50'    SHEET 1 OF 18 SHEETS    STA. 212+92 TO STA. 241+00

F.A.P. RTE.	SECTION	COUNTY	TOTAL SHEETS	SHEET NO.
322A	(46,47)RS-3, (58-20-1)RS-1	MACON	84	33
CONTRACT NO. 74779				
ILLINOIS FED. AID PROJECT				



EXIST. CURVE CURVE04  
 PI STA. = 274+51.96  
 $\Delta = 3^{\circ} 08' 18''$  (LT)  
 $D = 0^{\circ} 23' 00''$   
 $R = 14,946.72'$   
 $T = 409.44'$   
 $L = 818.68'$   
 $E = 5.61'$   
 $e = \text{NONE}$   
 P.C. STA. = 270+42.52  
 P.T. STA. = 278+61.19

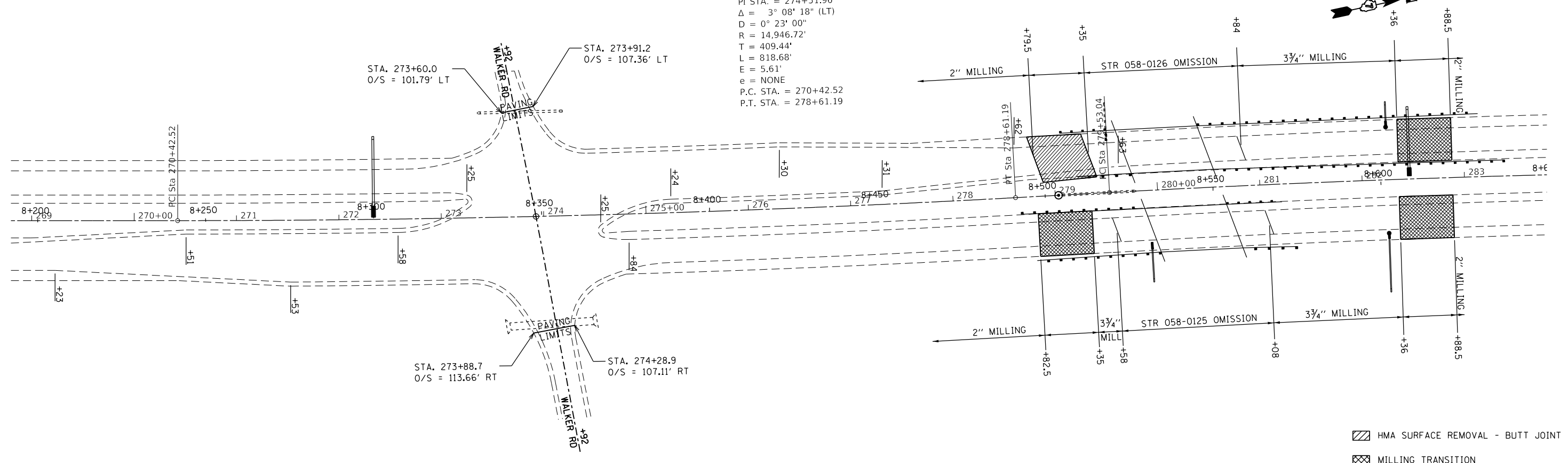

HMA SURFACE REMOVAL - BUTT JOINT  
 MILLING TRANSITION

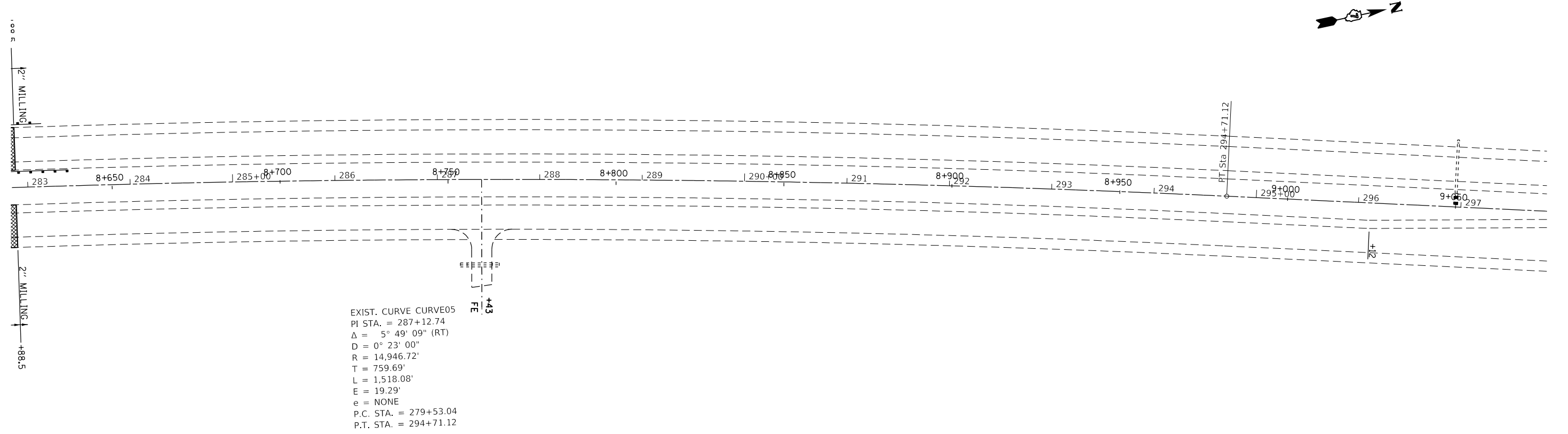

EXIST. CURVE CURVE05  
 PI STA. = 287+12.74  
 $\Delta = 5^{\circ} 49' 09''$  (RT)  
 $D = 0^{\circ} 23' 00''$   
 $R = 14,946.72'$   
 $T = 759.69'$   
 $L = 1,518.08'$   
 $E = 19.29'$   
 $e = \text{NONE}$   
 P.C. STA. = 279+53.04  
 P.T. STA. = 294+71.12

HMA SURFACE REMOVAL - BUTT JOINT  
 MILLING TRANSITION

FILE NAME =	USER NAME = steffenmk	DESIGNED -	REVISED -	<b>STATE OF ILLINOIS DEPARTMENT OF TRANSPORTATION</b>	<b>PLAN SHEET</b>			F.A.P. RTE.	SECTION	COUNTY	TOTAL SHEETS	SHEET NO.	
pww\planroom\dot.illinois.gov\PWIDOT\Documents\DOT Offices\District 7\Projects\74779\CADDData\CADSheets\DRAWN-shi-plan.dgn		CHECKED -	REVISED -		SCALE: 1" = 50'	SHEET 3	OF 18 SHEETS	STA. 269+00	TO STA. 297+00	322A	(46,47)RS-3, (58-20-1)RS-1	MACON	84 35
Default	PLOT SCALE = 100.0000' / in.	DATE -	REVISED -		CONTRACT NO. 74779								
	PLOT DATE = 1/29/2020				ILLINOIS FED. AID PROJECT								

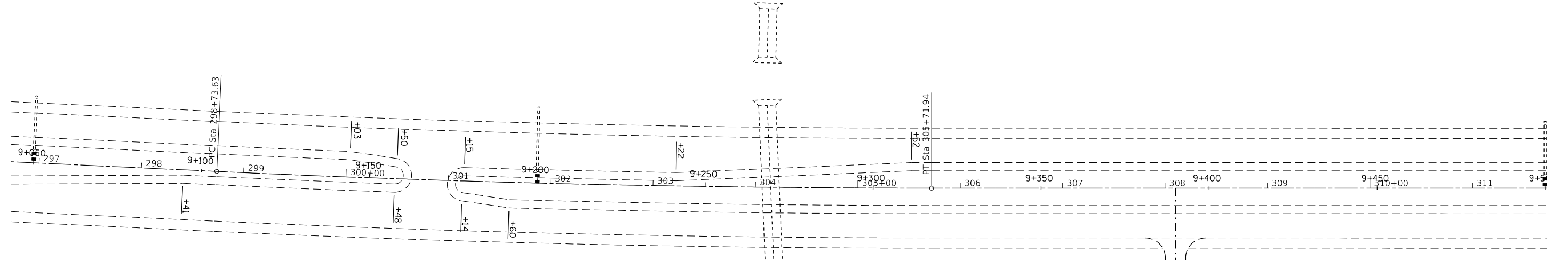

EXIST. CURVE CURVE06  
 PI STA. = 302+22.84  
 $\Delta$  = 2° 40' 37" (LT)  
 D = 0° 23' 00"  
 R = 14,946.72'  
 T = 349.22'  
 L = 698.31'  
 E = 4.08'  
 e = NONE  
 P.C. STA. = 298+73.63  
 P.T. STA. = 305+71.94

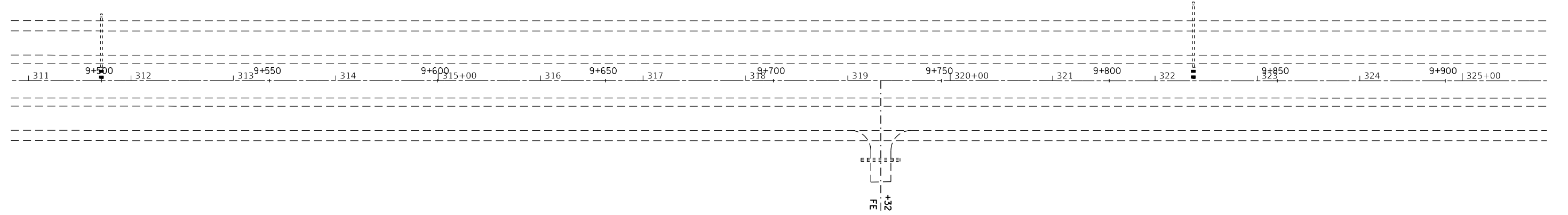

HMA SURFACE REMOVAL - BUTT JOINT  
 MILLING TRANSITION



HMA SURFACE REMOVAL - BUTT JOINT  
 MILLING TRANSITION

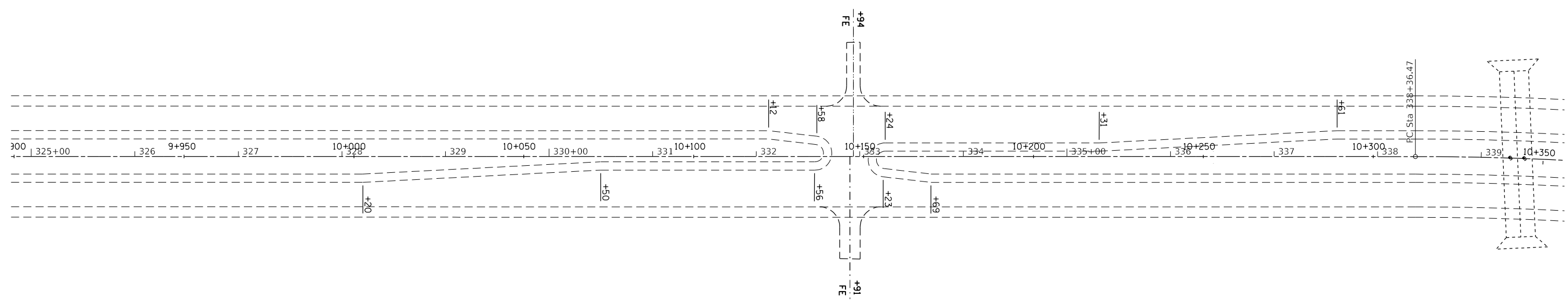

FILE NAME =	USER NAME = steffenmk	DESIGNED -	REVISED -	<b>STATE OF ILLINOIS DEPARTMENT OF TRANSPORTATION</b>	<b>PLAN SHEET</b>			F.A.P. RTE.	SECTION	COUNTY	TOTAL SHEETS	SHEET NO.	
pww\planroom.dot\illinois.gov\PWIDOT\Documents\DOT Offices\District 7\Projects\74779\CADDData\CADSheets\DRAWN-shi-plan.dgn					322A	(46,47)RS-3, (58-20-1)RS-1	MACON	84	36				
Default	PLOT SCALE = 100.0000 ' / in.	CHECKED -	REVISED -		SCALE: 1" = 50'			SHEET 4 OF 18 SHEETS		STA. 297+00 TO STA. 325+00		ILLINOIS FED. AID PROJECT	
	PLOT DATE = 1/29/2020	DATE -	REVISED -		CONTRACT NO. 74779								

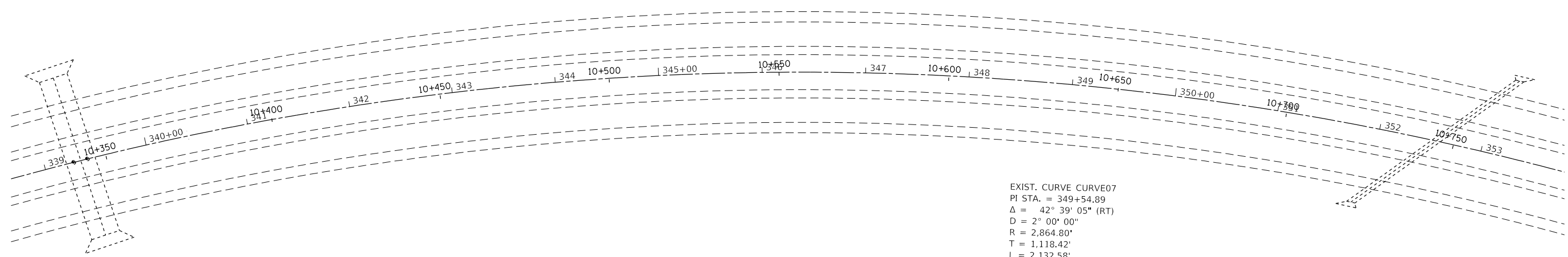
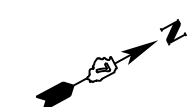

 HMA SURFACE REMOVAL - BUTT JOINT  
 MILLING TRANSITION





EXIST. CURVE CURVE07  
 PI STA. = 349+54.89  
 $\Delta = 42^\circ 39' 05''$  (RT)  
 $D = 2^\circ 00' 00''$   
 $R = 2,864.80'$   
 $T = 1,118.42'$   
 $L = 2,132.58'$   
 $E = 210.58'$   
 $e = 5.5\%$   
 S.E. ATTAINED STA 336+66.47 TO STA 339+21.47  
 S.E. REMOVED STA 358+84.07 TO STA 361+39.07  
 P.C. STA. = 338+36.47  
 P.T. STA. = 359+69.05

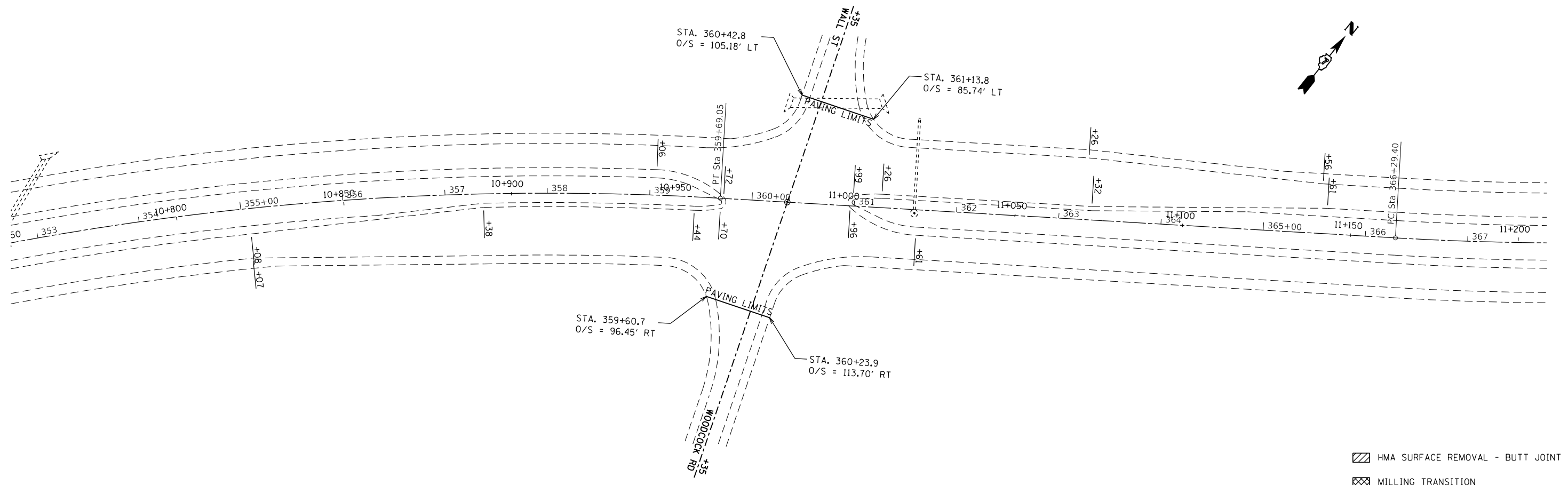

 HMA SURFACE REMOVAL - BUTT JOINT  
 MILLING TRANSITION

FILE NAME =	USER NAME = steffenmk	DESIGNED -	REVISED -	<b>STATE OF ILLINOIS DEPARTMENT OF TRANSPORTATION</b>	<b>PLAN SHEET</b>			F.A.P. RTE.	SECTION	COUNTY	TOTAL SHEETS	SHEET NO.
pww\planroom.dot\illinois.gov\PWIDOT\Documents\DOT Offices\District 7\Projects\74779\CADDData\CADSheets\DRAWN-shit-plan.dgn		CHECKED -	REVISED -		SCALE: 1" = 50'	SHEET 5 OF 18 SHEETS	STA. 325+00 TO STA. 353+00	322A	(46,47)RS-3, (58-20-1)RS-1	MACON	84	37
Default	PLOT SCALE = 100.0000' / in.	DATE -	REVISED -					CONTRACT NO. 74779				
	PLOT DATE = 1/29/2020							ILLINOIS FED. AID PROJECT				

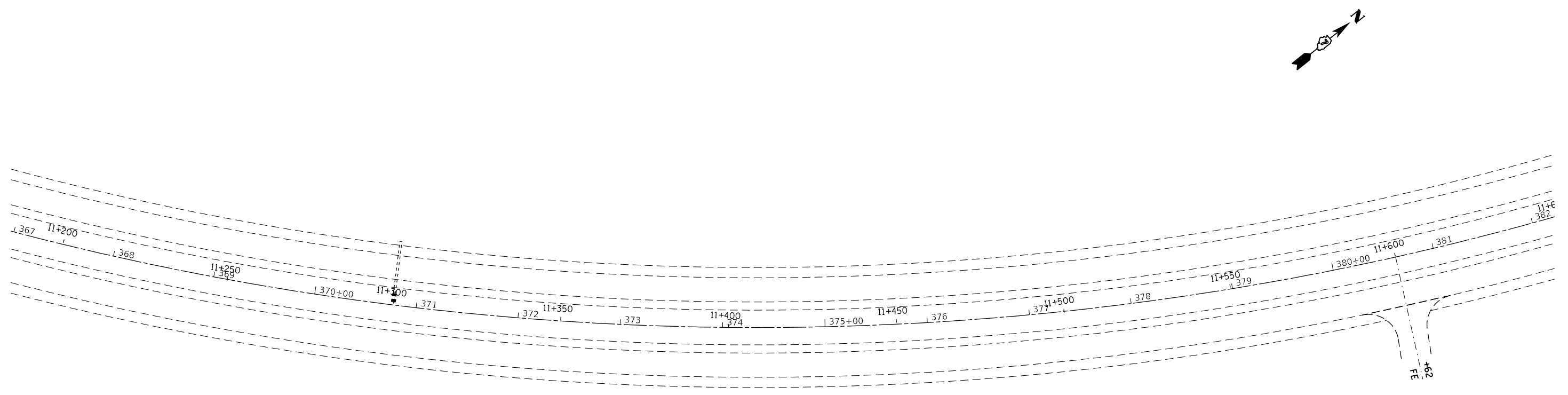

 HMA SURFACE REMOVAL - BUTT JOINT  
 MILLING TRANSITION



 HMA SURFACE REMOVAL - BUTT JOINT  
 MILLING TRANSITION

FILE NAME =	USER NAME = steffenmk	DESIGNED -	REVISED -	<b>STATE OF ILLINOIS DEPARTMENT OF TRANSPORTATION</b>	<b>PLAN SHEET</b>			F.A.P. RTE.	SECTION	COUNTY	TOTAL SHEETS	SHEET NO.
pww\planroom.dot\illinois.gov\PWIDOT\Documents\DOT Offices\District 7\Projects\74779\CADDData\CADSheets\DRAWN-sh1-plan.dgn		CHECKED -	REVISED -		SCALE: 1" = 50'	SHEET 6	OF 18 SHEETS	322A	(46,47)RS-3, (58-20-1)RS-1	MACON	84	38
Default		DATE -	REVISED -		STA. 353+00	TO STA. 382+00		CONTRACT NO. 74779				
	PLOT DATE = 1/29/2020				ILLINOIS FED. AID PROJECT							

EXIST. CURVE CURVE08  
 PI STA. = 383+85.40  
 $\Delta = 63^\circ 00' 46''$  (LT)  
 $D = 2^\circ 00' 00''$   
 $R = 2,864.80'$   
 $T = 1,755.99'$   
 $L = 3,150.65'$   
 $E = 495.35'$   
 $e = 5.5\%$   
 S.E. ATTAINED STA 364+59.41 TO STA 367+14.41  
 S.E. REMOVED STA 396+95.08 TO STA 399+50.08  
 P.C. STA. = 366+29.40  
 P.T. STA. = 397+80.06

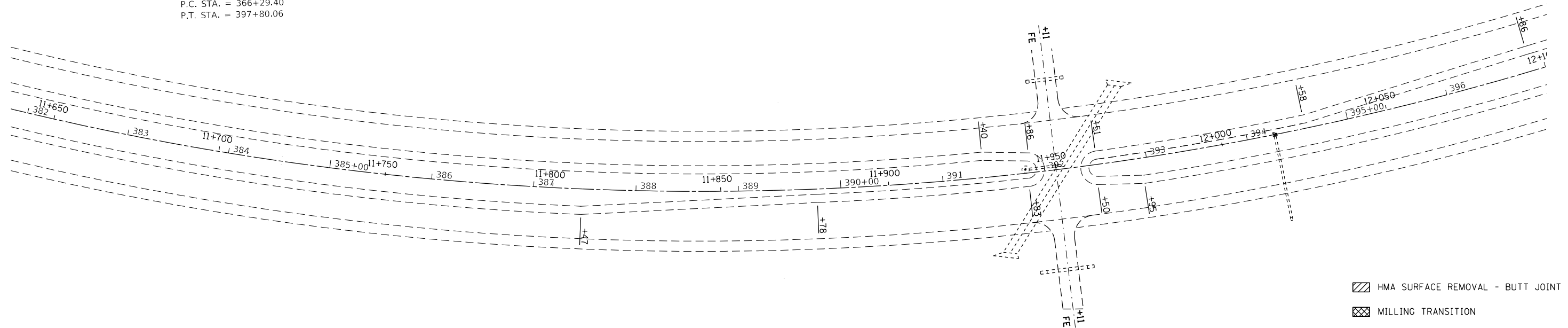

HMA SURFACE REMOVAL - BUTT JOINT  
 MILLING TRANSITION

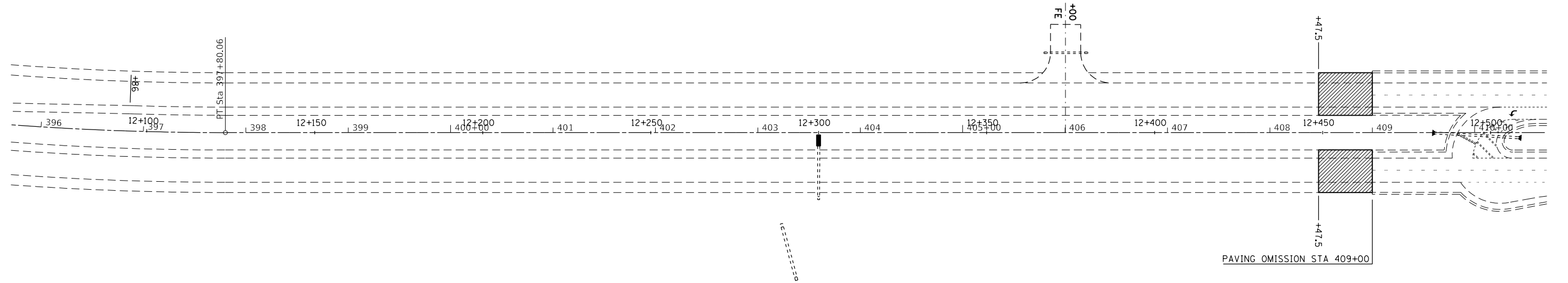

HMA SURFACE REMOVAL - BUTT JOINT  
 MILLING TRANSITION

FILE NAME =	USER NAME = stefenmk	DESIGNED -	REVISED -
p:\planroom\dot\illinois.gov\PWIDOT\Documents\DOT Offices\District 7\Projects\74779\CADDData\CADsheets\DRAWN-sh1-plan.dgn			
	PLOT SCALE = 100.0000 ' / in.	CHECKED -	REVISED -
Default	PLOT DATE = 1/29/2020	DATE -	REVISED -

**STATE OF ILLINOIS  
 DEPARTMENT OF TRANSPORTATION**

**PLAN SHEET**

SCALE: 1" = 50' SHEET 7 OF 18 SHEETS STA. 382+00 TO STA. 410+00

F.A.P. RTE.	SECTION	COUNTY	TOTAL SHEETS	SHEET NO.
322A	(46,47)RS-3, (58-20-1)RS-1	MACON	84	39
ILLINOIS FED. AID PROJECT			CONTRACT NO. 74779	

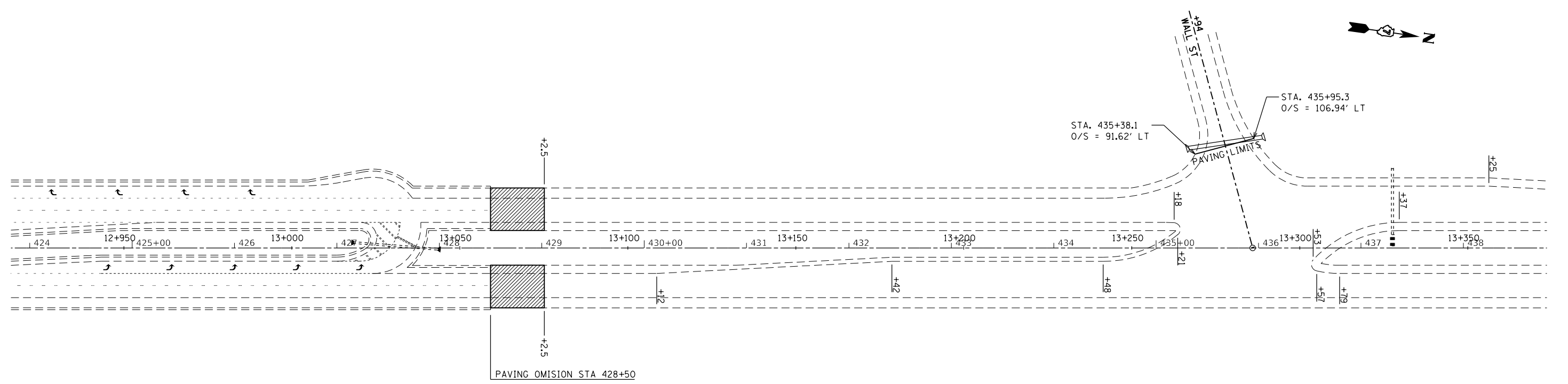
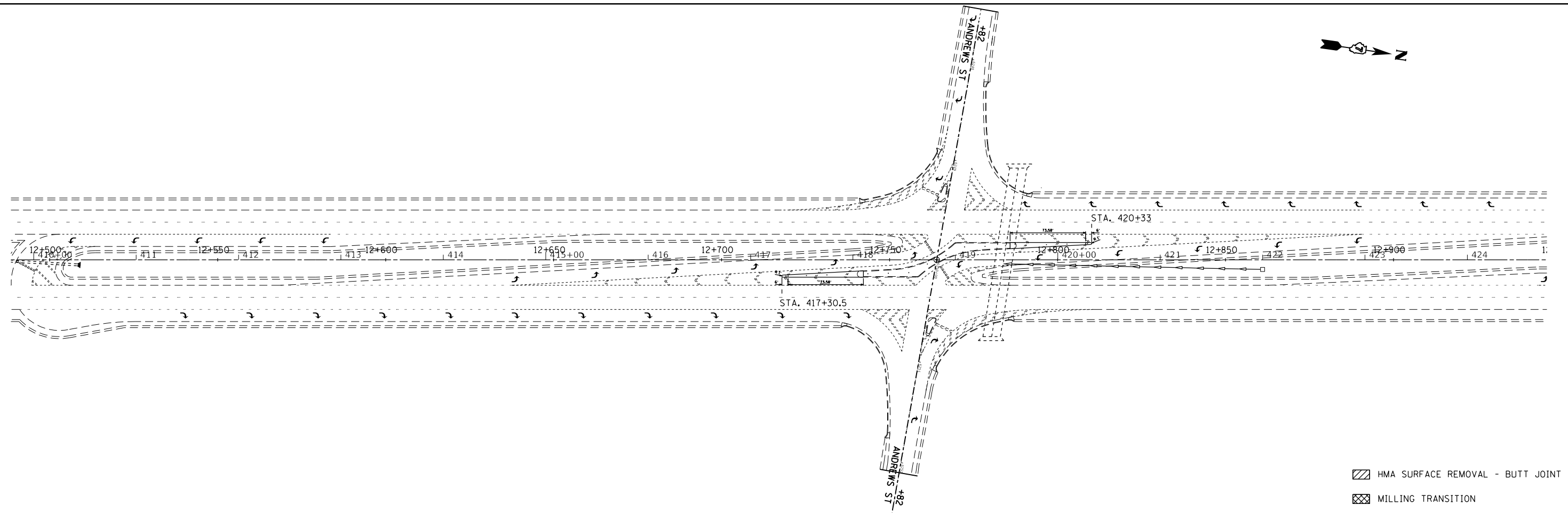

FILE NAME =	USER NAME = steffemk	DESIGNED -	REVISED -
pww\planroom.dot\illinois.gov\PWIDOT\Documents\DOT Offices\District 7\Projects\74779\CADDData\CADSheets\DRAWN-shi-plan.dgn		DRAWN -	REVISED -
	PLOT SCALE = 100.0000' / in.	CHECKED -	REVISED -
Default	PLOT DATE = 1/29/2020	DATE -	REVISED -

**STATE OF ILLINOIS  
DEPARTMENT OF TRANSPORTATION**

**PLAN SHEET**

SCALE: 1" = 50'    SHEET 8 OF 18 SHEETS    STA. 410+00 TO STA. 438+00

F.A.P. RTE.	SECTION	COUNTY	TOTAL SHEETS	SHEET NO.
322A	(46,47)RS-3, (58-20-1)RS-1	MACON	84	40
CONTRACT NO. 74779				
ILLINOIS FED. AID PROJECT				



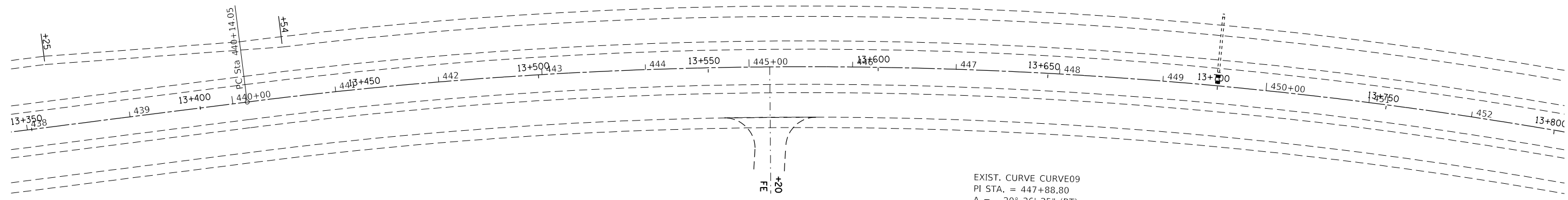
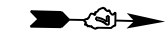

EXIST. CURVE CURVE09  
 PI STA. = 447+88.80  
 $\Delta$  = 20° 26' 25" (RT)  
 D = 1° 20' 00"  
 R = 4,297.18'  
 T = 774.75'  
 L = 1,533.03'  
 E = 69.28'  
 e = 4.0%  
 S.E. ATTAINED STA 438+44.06 TO STA 440+99.06  
 S.E. REMOVED STA 454+62.11 TO STA 457+17.11  
 P.C. STA. = 440+14.05  
 P.T. STA. = 455+47.08

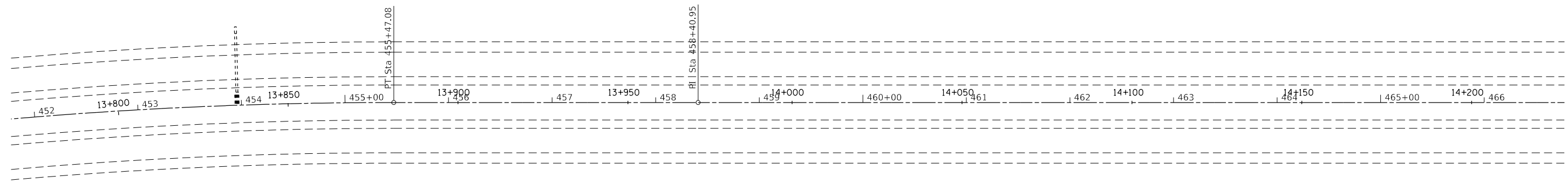

- HMA SURFACE REMOVAL - BUTT JOINT
- MILLING TRANSITION



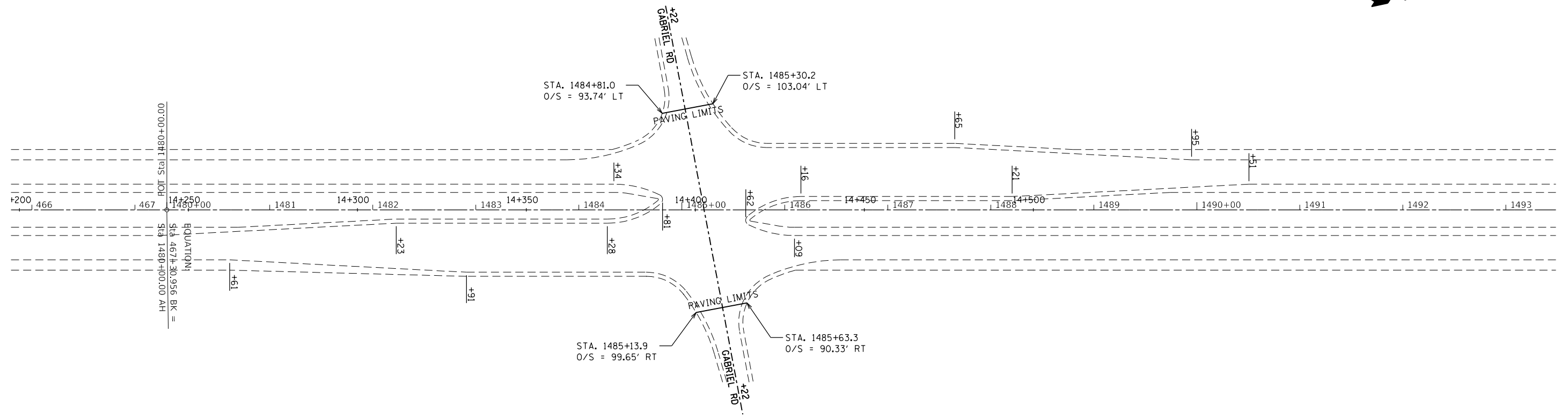

- HMA SURFACE REMOVAL - BUTT JOINT
- MILLING TRANSITION

FILE NAME =	USER NAME = steffemk	DESIGNED -	REVISED -	<b>STATE OF ILLINOIS DEPARTMENT OF TRANSPORTATION</b>	<b>PLAN SHEET</b>			F.A.P. RTE.	SECTION	COUNTY	TOTAL SHEETS	SHEET NO.
pww\planroom\dot.illinois.gov\PWIDOT\Documents\DOT Offices\District 7\Projects\74779\CADDData\CAD\Sheets\DRAWN-sh1-plan.dgn								322A	(46,47)RS-3, (58-20-1)RS-1	MACON	84	41
Default	PLOT SCALE = 100.0000' / in.	CHECKED -	REVISED -		SCALE: 1" = 50'			SHEET 9 OF 18 SHEETS STA. 438+00 TO STA. 466+00			CONTRACT NO. 74779	
	PLOT DATE = 1/29/2020	DATE -	REVISED -		ILLINOIS FED. AID PROJECT							



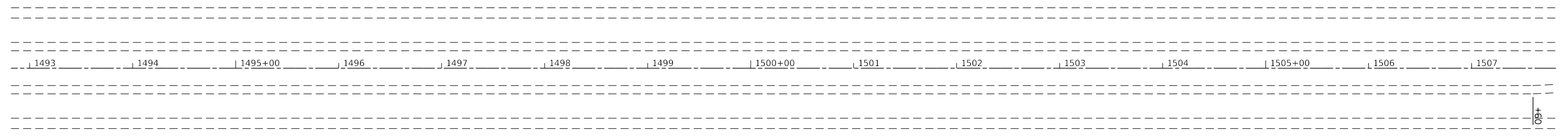

 HMA SURFACE REMOVAL - BUTT JOINT  
 MILLING TRANSITION



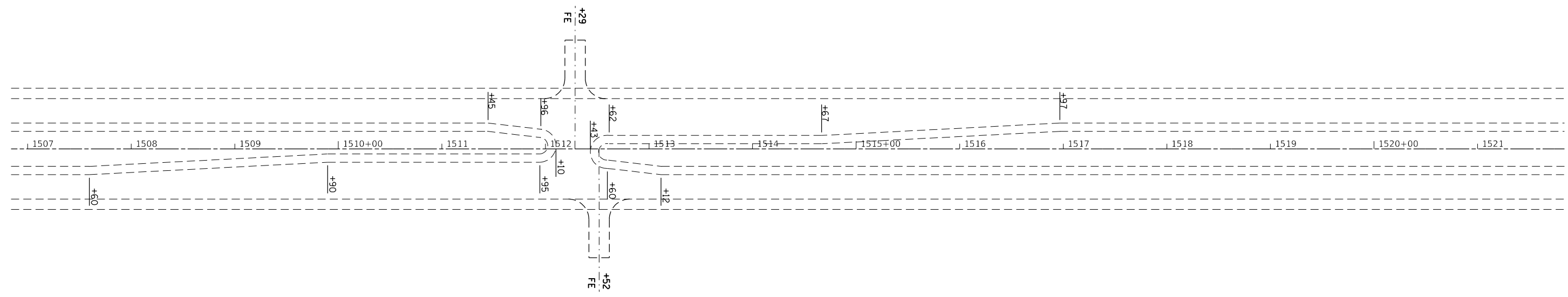

 HMA SURFACE REMOVAL - BUTT JOINT  
 MILLING TRANSITION

FILE NAME =	USER NAME = stefenmk	DESIGNED -	REVISED -	<b>STATE OF ILLINOIS DEPARTMENT OF TRANSPORTATION</b>	<b>PLAN SHEET</b>		F.A.P. RTE.	SECTION	COUNTY	TOTAL SHEETS	SHEET NO.
pww\planroom\dot.illinois.gov\PWIDOT\Documents\DOT Offices\District 7\Projects\74779\CADDData\CAD\Sheets\DRAWN-shit-plan.dgn		CHECKED -	REVISED -				322A	(46,47)RS-3, (58-20-1)RS-1	MACON	84	42
Default	PLOT SCALE = 100.0000 ' / in.	DATE -	REVISED -		CONTRACT NO. 74779			ILLINOIS	FED. AID PROJECT		
	PLOT DATE = 1/29/2020				SCALE: 1" = 50'	SHEET 10 OF 18 SHEETS	STA. 466+00 TO STA. 1507+00				



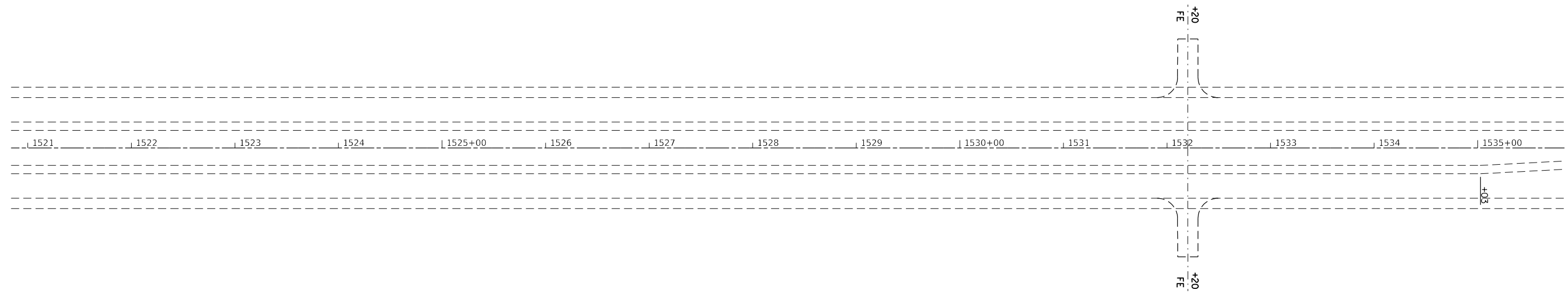

 HMA SURFACE REMOVAL - BUTT JOINT  
 MILLING TRANSITION



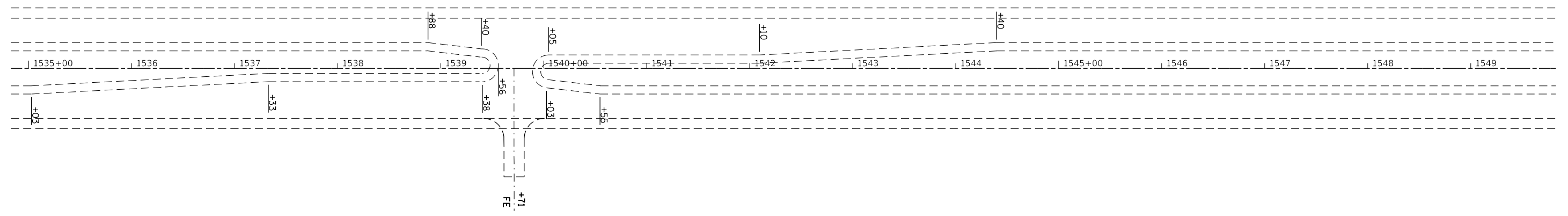

 HMA SURFACE REMOVAL - BUTT JOINT  
 MILLING TRANSITION

FILE NAME =	USER NAME = steffenmk	DESIGNED -	REVISED -	<b>STATE OF ILLINOIS DEPARTMENT OF TRANSPORTATION</b>	<b>PLAN SHEET</b>		F.A.P. RTE.	SECTION	COUNTY	TOTAL SHEETS	SHEET NO.	
pww\planroom.dot\illinois.gov\PWIDOT\Documents\DOT Offices\District 7\Projects\74779\CADDData\CADsheets\DRAWN-shit-plan.dgn							322A	(46,47)RS-3, (58-20-1)RS-1	MACON	84	43	
Default	PLOT SCALE = 100.0000 ' / in.	CHECKED -	REVISED -		SCALE: 1" = 50'		SHEET 11 OF 18 SHEETS		STA. 1507+00 TO STA. 1535+00		CONTRACT NO. 74779	
	PLOT DATE = 1/29/2020	DATE -	REVISED -		ILLINOIS FED. AID PROJECT							

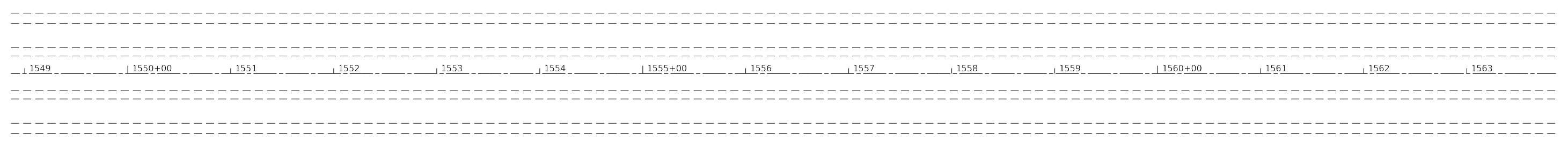

 HMA SURFACE REMOVAL - BUTT JOINT  
 MILLING TRANSITION



 HMA SURFACE REMOVAL - BUTT JOINT  
 MILLING TRANSITION

FILE NAME =	USER NAME = steffenmk	DESIGNED -	REVISED -	<b>STATE OF ILLINOIS DEPARTMENT OF TRANSPORTATION</b>	<b>PLAN SHEET</b>		F.A.P. RTE.	SECTION	COUNTY	TOTAL SHEETS	SHEET NO.
pww\planroom\dot.illinois.gov\PWIDOT\Documents\DOT Offices\District 7\Projects\74779\CADDData\CADsheets\DRAWN-shit-plan.dgn							322A	(46,47)RS-3, (58-20-1)RS-1	MACON	84	44
Default	PLOT SCALE = 100.0000 ' / in.	CHECKED -	REVISED -		CONTRACT NO. 74779						
	PLOT DATE = 1/29/2020	DATE -	REVISED -		SCALE: 1" = 50'	SHEET 12 OF 18 SHEETS	STA. 1535+00 TO STA. 1563+00	ILLINOIS	FED. AID PROJECT		

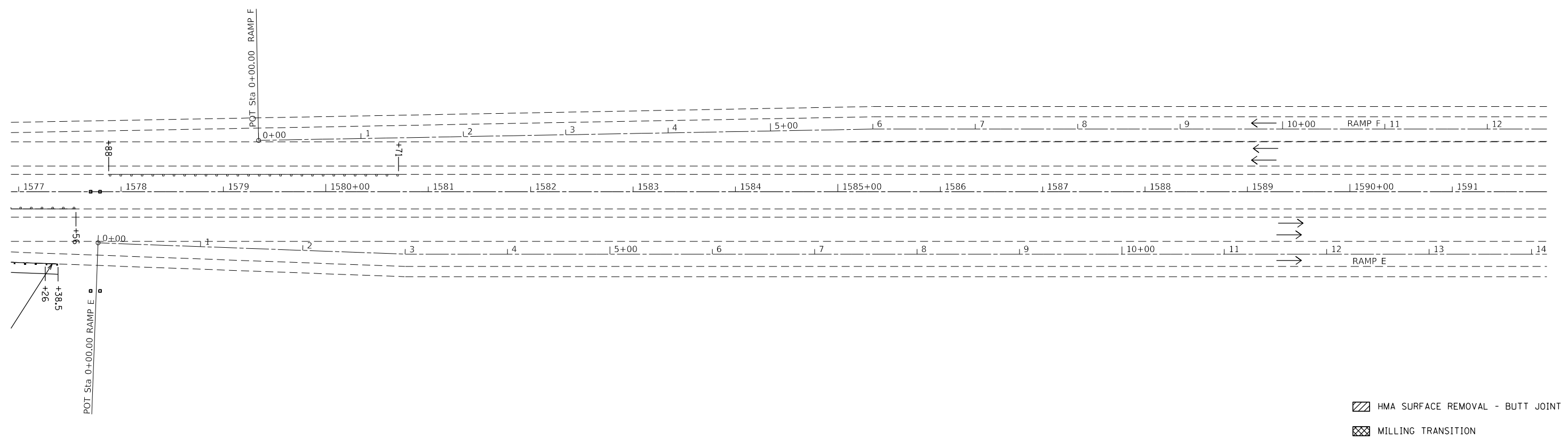
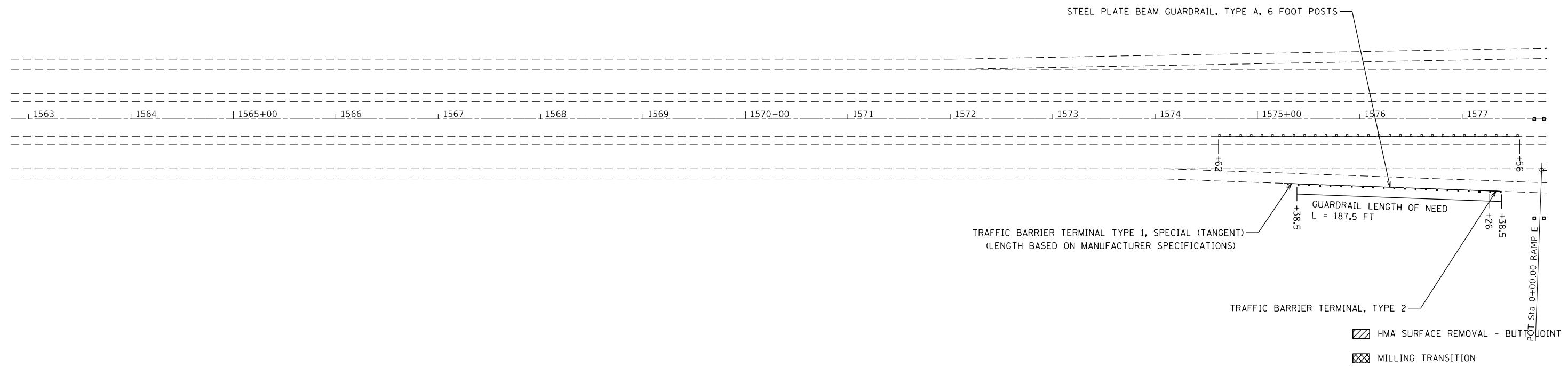

FILE NAME =	USER NAME = steffemk	DESIGNED -	REVISED -	<b>STATE OF ILLINOIS DEPARTMENT OF TRANSPORTATION</b>	<b>PLAN SHEET</b>			F.A.P. RTE.	SECTION	COUNTY	TOTAL SHEETS	SHEET NO.
pwz\planroom.dot.illinois.gov\PWIDOT\Documents\DOT Offices\District 7\Projects\74779\CADDData\CADsheets\DRAWN-shi-plan.dgn		CHECKED -	REVISED -					322A	(46,47)RS-3, (58-20-1)RS-1	MACON	84	45
Default	PLOT SCALE = 100.0000' / in.	DATE -	REVISED -		SCALE: 1" = 50'			SHEET 13 OF 18 SHEETS STA. 1563+00 TO STA. 1591+00			CONTRACT NO. 74779	
	PLOT DATE = 1/29/2020				ILLINOIS FED. AID PROJECT							

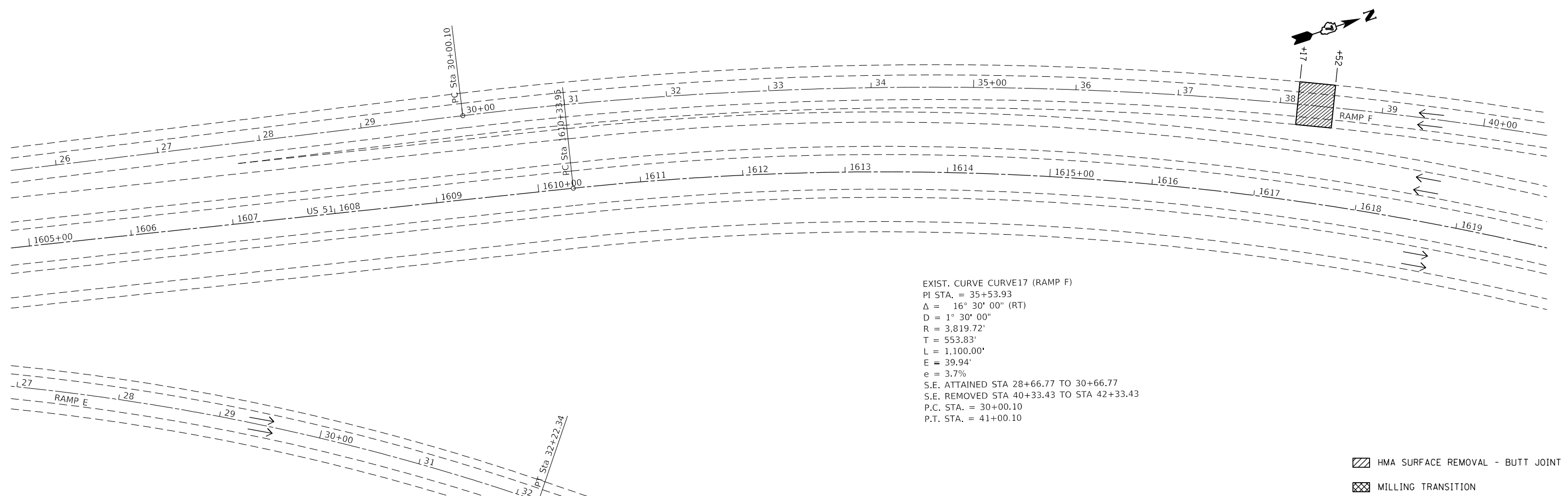
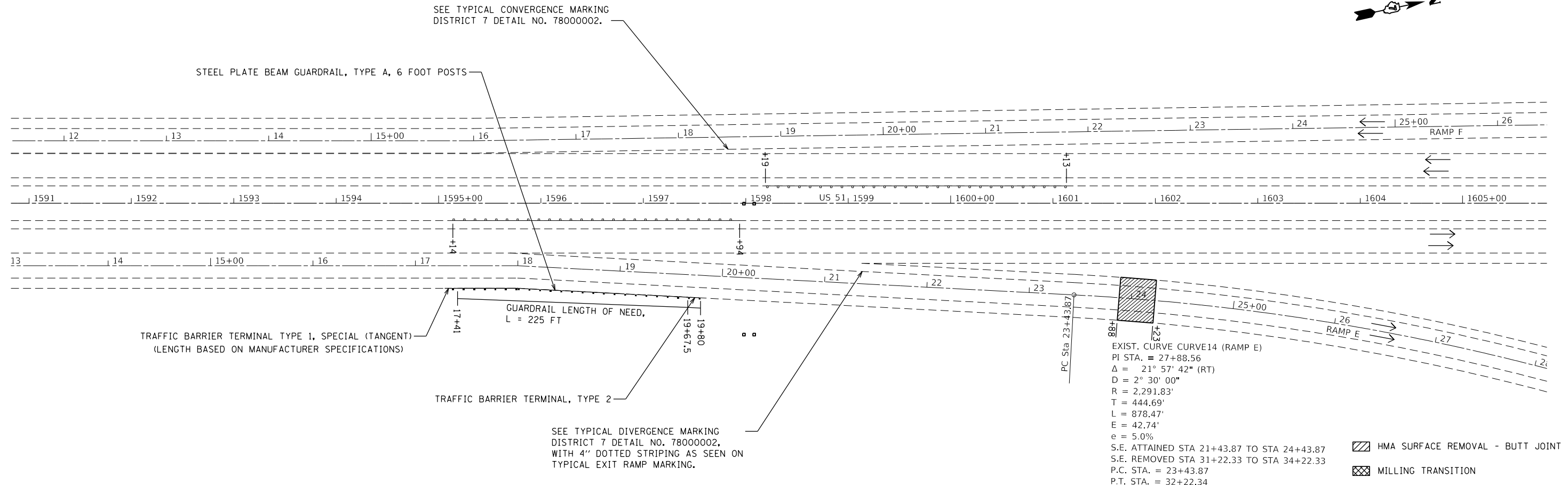

FILE NAME =	USER NAME = steffenmk	DESIGNED -	REVISED -
pwz\planroom.dot\illinois.gov\PWIDOT\Documents\DOT Offices\District 7\Projects\74779\CADDData\CADSheets\DRAWN-shit-plan.dgn		CHECKED -	REVISED -
Default	PLOT SCALE = 100.0000' / in.	DATE -	REVISED -
	PLOT DATE = 1/29/2020		

**STATE OF ILLINOIS  
DEPARTMENT OF TRANSPORTATION**

**PLAN SHEET**

SCALE: 1" = 50'    SHEET 14 OF 18 SHEETS    STA. 1591+00 TO STA. 1619+00

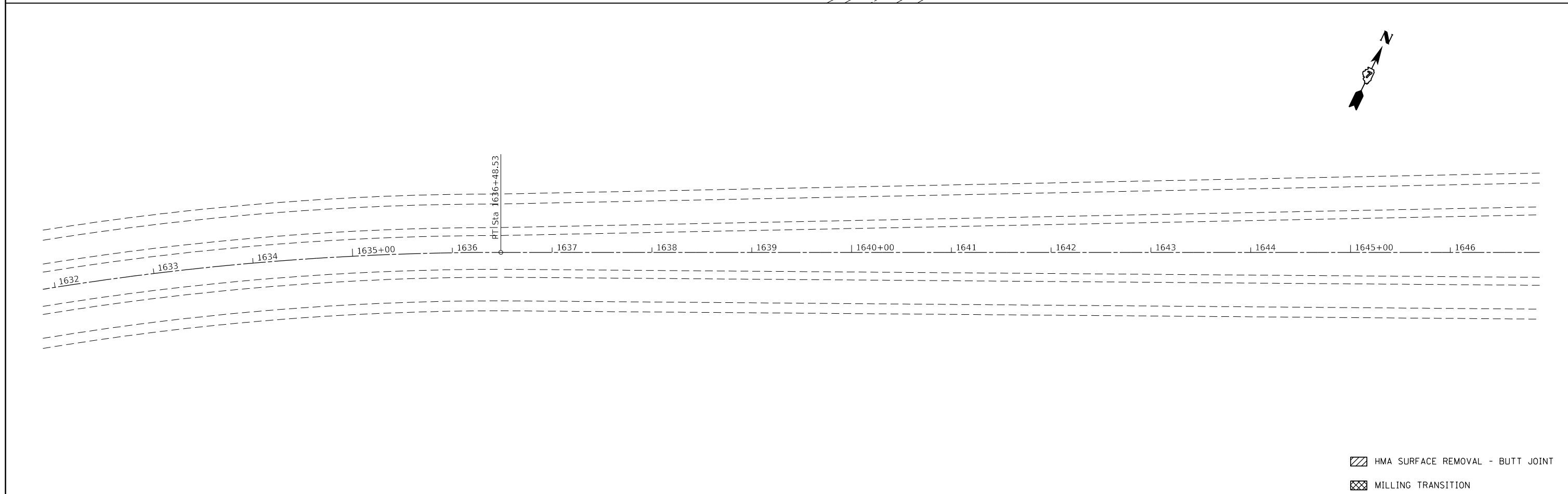
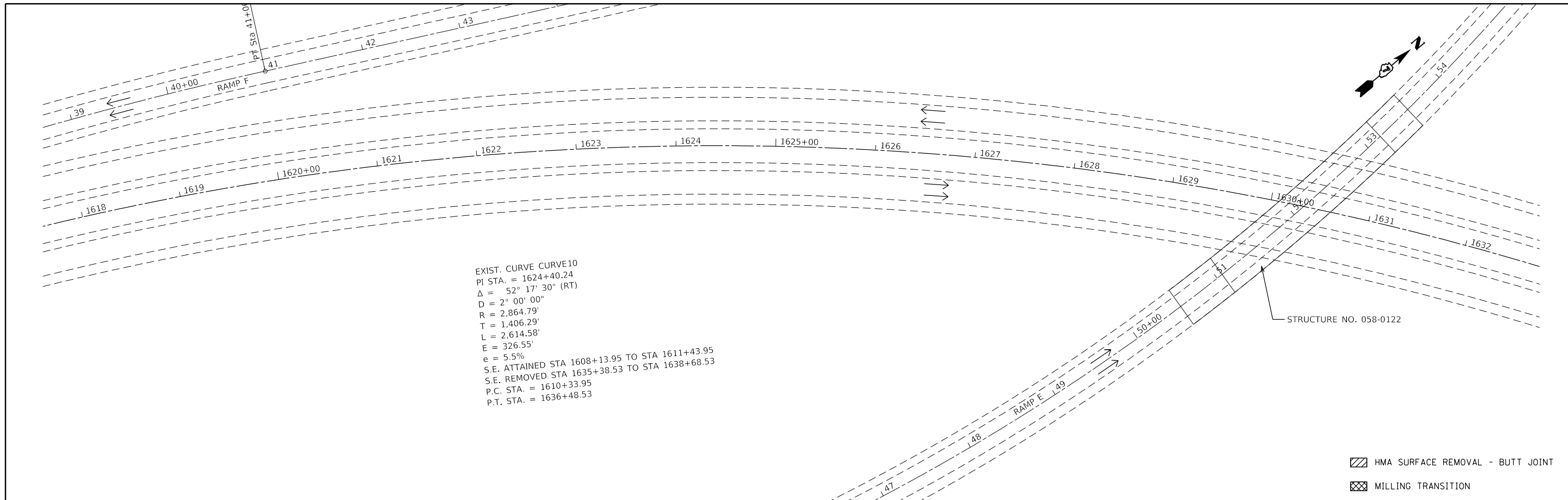

F.A.P. RTE.	SECTION	COUNTY	TOTAL SHEETS	SHEET NO.
322A	(46,47)RS-3, (58-20-1)RS-1	MACON	84	46
CONTRACT NO. 74779				
ILLINOIS FED. AID PROJECT				



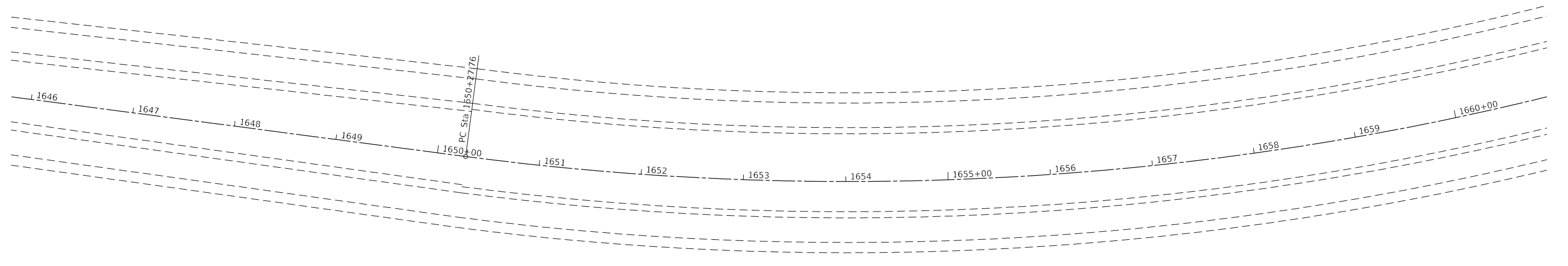

FILE NAME =	USER NAME = steffemk	DESIGNED -	REVISED -	<b>STATE OF ILLINOIS DEPARTMENT OF TRANSPORTATION</b>	<b>PLAN SHEET</b>		F.A.P. RTE.	SECTION	COUNTY	TOTAL SHEETS	SHEET NO.
pwz\planroom.dot\illinois.gov\PWIDOT\Documents\DOT Offices\District 7\Projects\74779\CADDData\CADsheets\DRAWN-sh1-plan.dgn							322A	(46,47)RS-3, (58-20-1)RS-1	MACON	84	47
Default	PLOT SCALE = 100.0000 ' / in.	CHECKED -	REVISED -		CONTRACT NO. 74779						
	PLOT DATE = 1/29/2020	DATE -	REVISED -		ILLINOIS FED. AID PROJECT						

SCALE: 1" = 50' SHEET 15 OF 18 SHEETS STA. 1619+00 TO STA. 1646+00

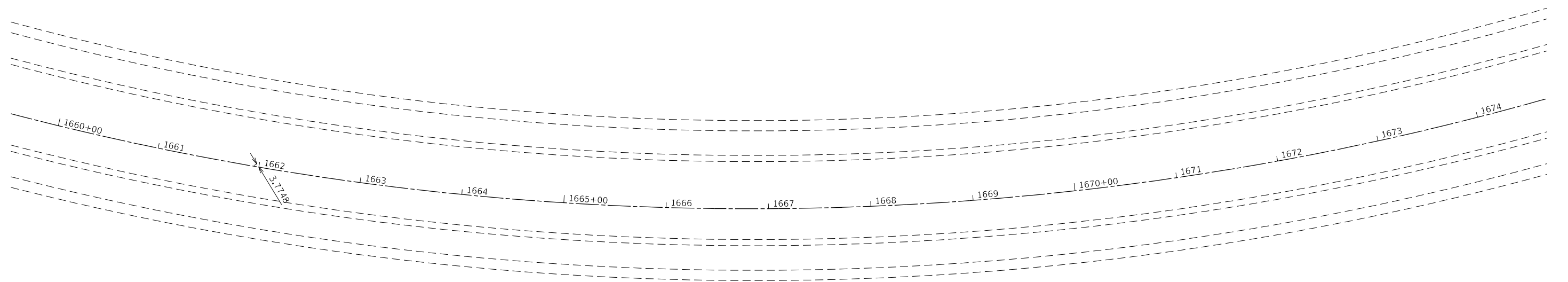
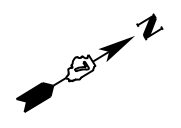

 HMA SURFACE REMOVAL - BUTT JOINT  
 MILLING TRANSITION



 HMA SURFACE REMOVAL - BUTT JOINT  
 MILLING TRANSITION

FILE NAME =	USER NAME = steffemk	DESIGNED -	REVISED -	<b>STATE OF ILLINOIS DEPARTMENT OF TRANSPORTATION</b>	<b>PLAN SHEET</b>			F.A.P. RTE.	SECTION	COUNTY	TOTAL SHEETS	SHEET NO.		
pww\planroom\dot.illinois.gov\PWIDOT\Documents\DOT Offices\District 7\Projects\74779\CADDData\CADSheets\DRAWN-sh1-plan.dgn		CHECKED -	REVISED -		SCALE: 1" = 50'	SHEET 16	OF 18 SHEETS	STA. 1646+00	TO STA. 1674+00	322A	(46,47)RS-3, (58-20-1)RS-1	MACON	84	48
Default	PLOT SCALE = 100.0000 ' / in.	DATE -	REVISED -		CONTRACT NO. 74779									
	PLOT DATE = 1/29/2020				ILLINOIS FED. AID PROJECT									



EXIST. CURVE CURVE11  
 PI STA. = 1685+68.88  
 $\Delta$  = 102° 03' 14" (LT)  
 D = 2° 00' 00"  
 R = 2,864.79'  
 T = 3,541.12'  
 L = 5,102.70'  
 E = 1,690.05'  
 e = 5.5%  
 S.E. ATTAINED STA 1648+07.76 TO STA 1651+37.76  
 S.E. REMOVAL STA 1699+73.42 (NB) TO STA 1703+03.42 (NB)  
 S.E. REMOVAL STA 1700+67.09 (SB) TO STA 1703+97.09 (SB)  
 P.C. STA. = 1650+27.76  
 P.T. STA. = 1701+30.45

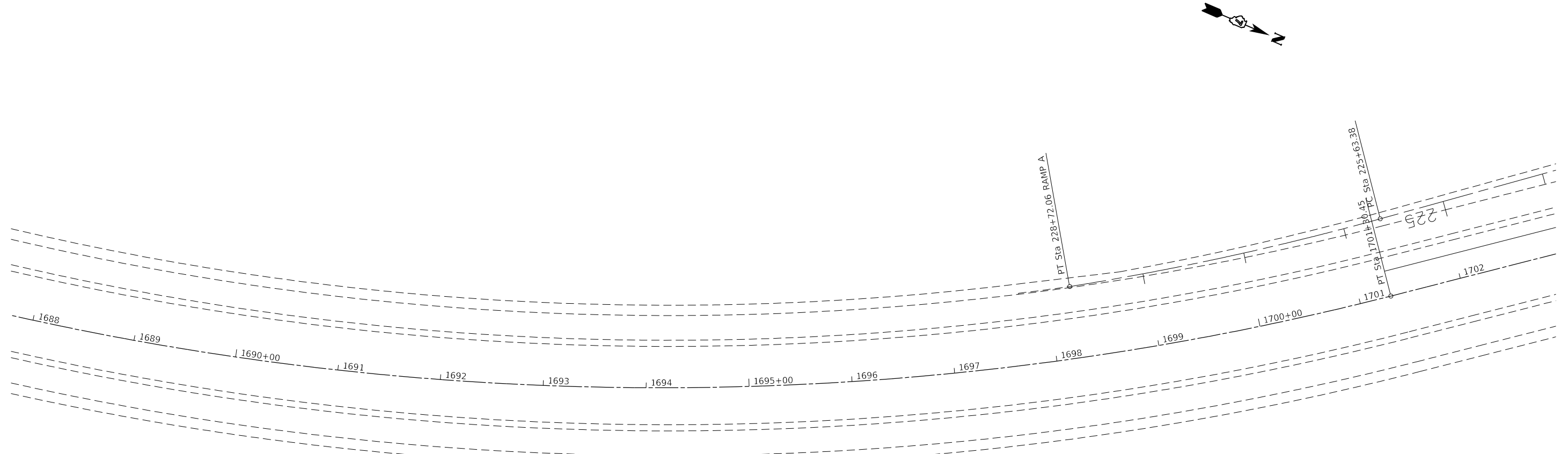
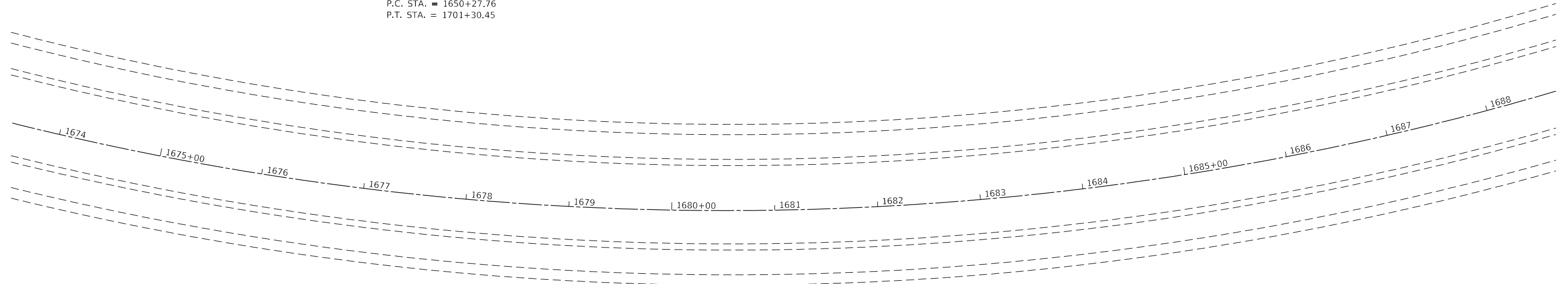

FILE NAME =	USER NAME = steffemk	DESIGNED -	REVISED -
pwz\planroom\dot.illinois.gov\PWIDOT\Documents\DOT Offices\District 7\Projects\74779\CADDData\CADsheets\DRAWN-shit-plan.dgn			
PLOT SCALE = 100.0000 ' / in.	CHECKED -	REVISED -	
PLOT DATE = 1/29/2020	DATE -	REVISED -	

**STATE OF ILLINOIS  
 DEPARTMENT OF TRANSPORTATION**

**PLAN SHEET**

SCALE: 1" = 50'    SHEET 17 OF 18 SHEETS    STA. 1674+00 TO STA. 1702+00

F.A.P. RTE.	SECTION	COUNTY	TOTAL SHEETS	SHEET NO.
322A	(46,47)RS-3, (58-20-1)RS-1	MACON	84	49
CONTRACT NO. 74779				
ILLINOIS FED. AID PROJECT				

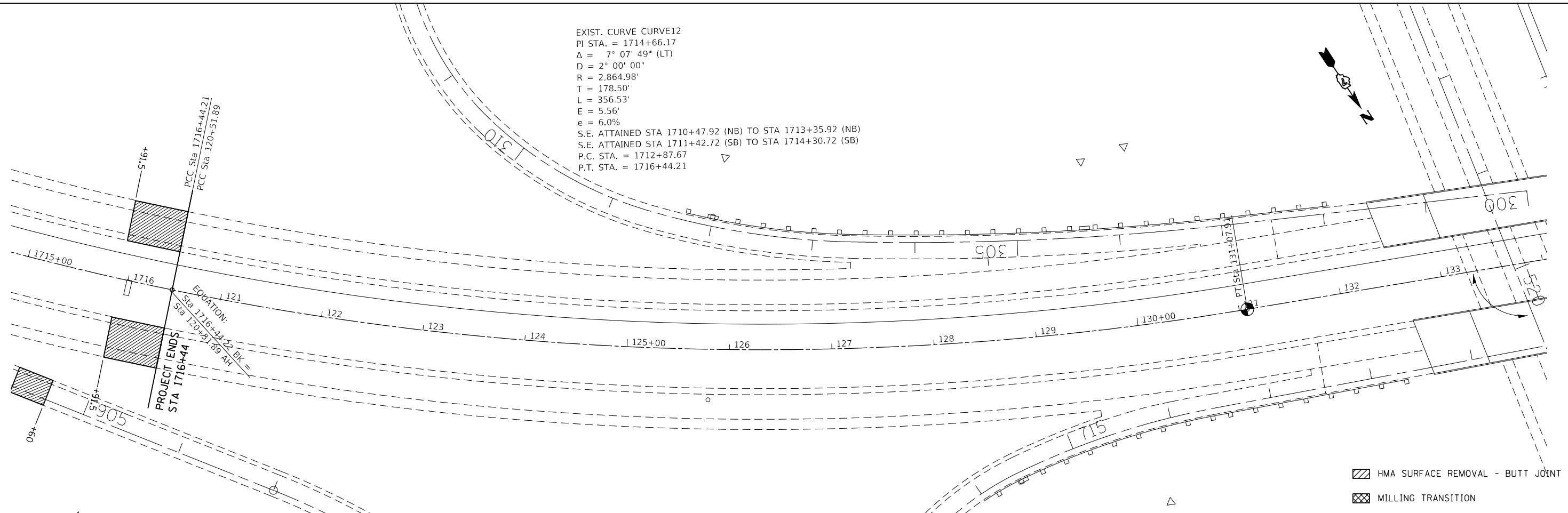
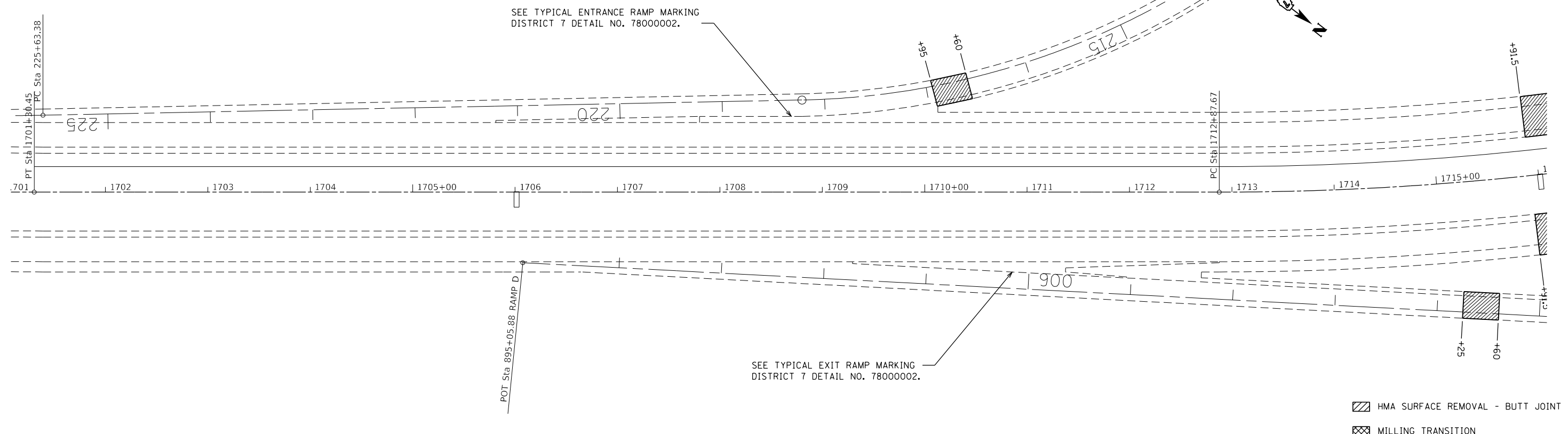

FILE NAME =	USER NAME = stefenmk	DESIGNED -	REVISED -	<b>STATE OF ILLINOIS DEPARTMENT OF TRANSPORTATION</b>	<b>PLAN SHEET</b>			F.A.P. RTE.	SECTION	COUNTY	TOTAL SHEETS	SHEET NO.	
p:\planroom\dot.illinois.gov\PWIDOT\Documents\DOT Offices\District 7\Projects\74779\CADDData\CADsheets\DRAWN-sh1-plan.dgn		CHECKED -	REVISED -		SCALE: 1" = 50'	SHEET 18	OF 18 SHEETS	STA. 1702+00	TO STA. 1716+44	322A	(46,47)RS-3, (58-20-1)RS-1	MACON	84 50
Default	PLOT SCALE = 100.0000 ' / in.	DATE -	REVISED -		CONTRACT NO. 74779								
	PLOT DATE = 1/29/2020				ILLINOIS FED. AID PROJECT								

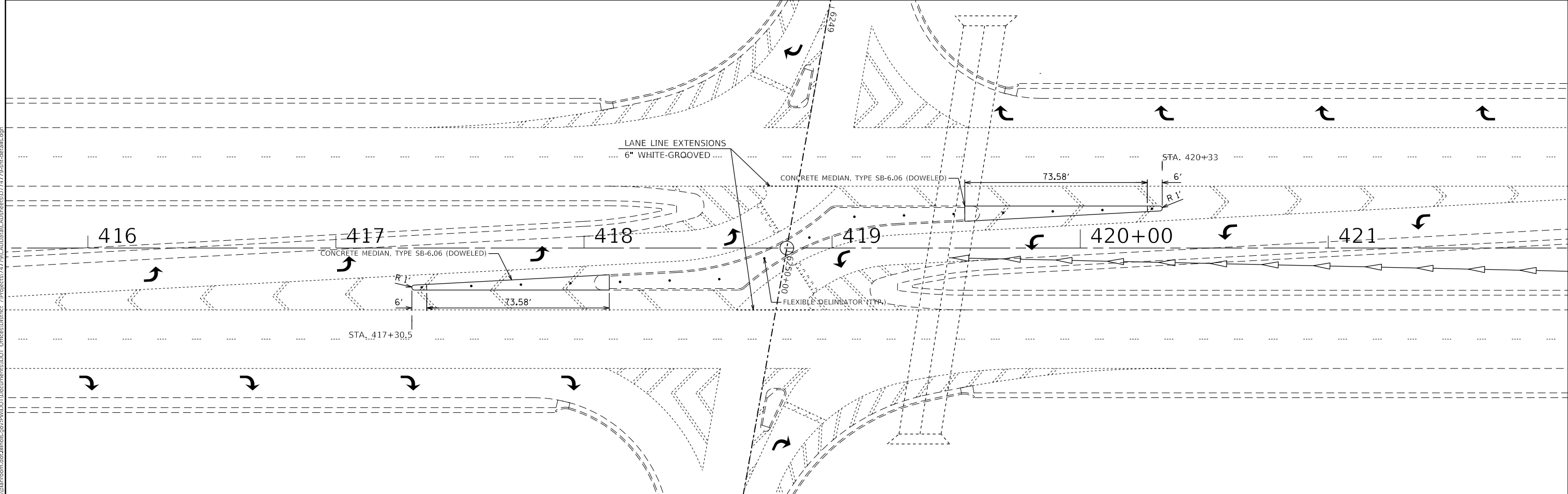
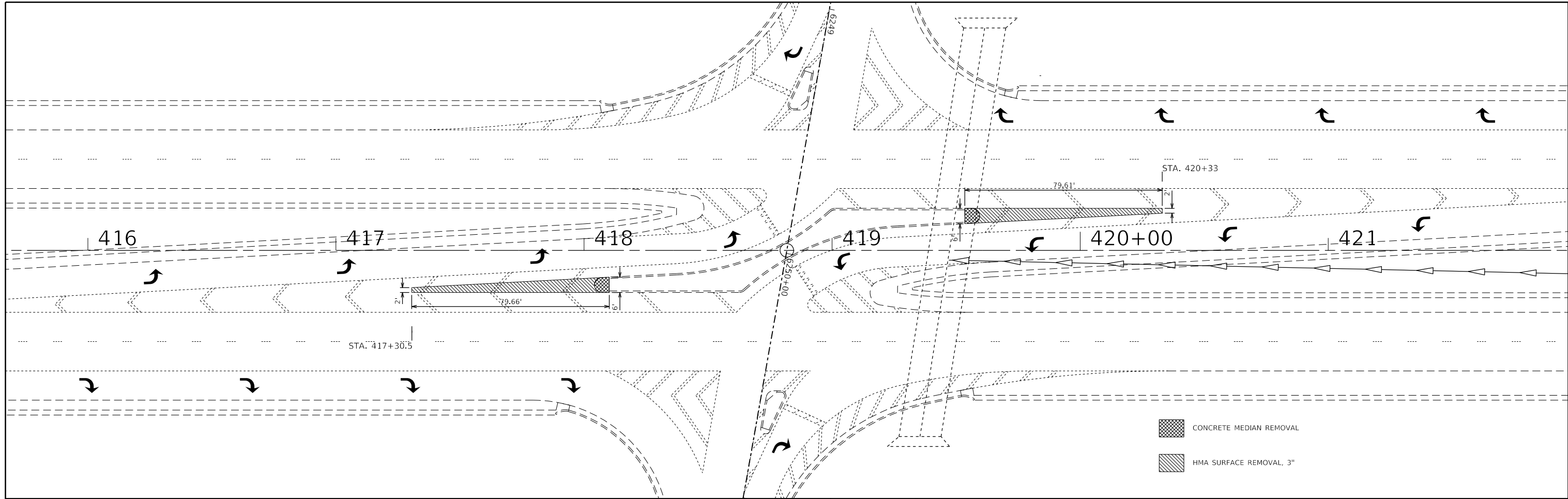

MODEL: Default  
 FILE: Model: 322A (46,47)RS-3, (58-20-1)RS-1.dwg  
 PROJECT: 322A (46,47)RS-3, (58-20-1)RS-1  
 OFFICE: District 7  
 DATE: 1/30/2020

USER NAME = steffenmk	DESIGNED -	REVISED -
	DRAWN -	REVISED -
PLOT SCALE = 40,0000 ' / in.	CHECKED -	REVISED -
PLOT DATE = 1/30/2020	DATE -	REVISED -

**STATE OF ILLINOIS**  
**DEPARTMENT OF TRANSPORTATION**

SCALE: SHEET OF SHEETS STA. TO STA.

F.A.P. RTE.	SECTION	COUNTY	TOTAL SHEETS	SHEET NO.
322A	(46,47)RS-3, (58-20-1)RS-1	MACON	84	51
CONTRACT NO. 74779				
ILLINOIS FED. AID PROJECT				

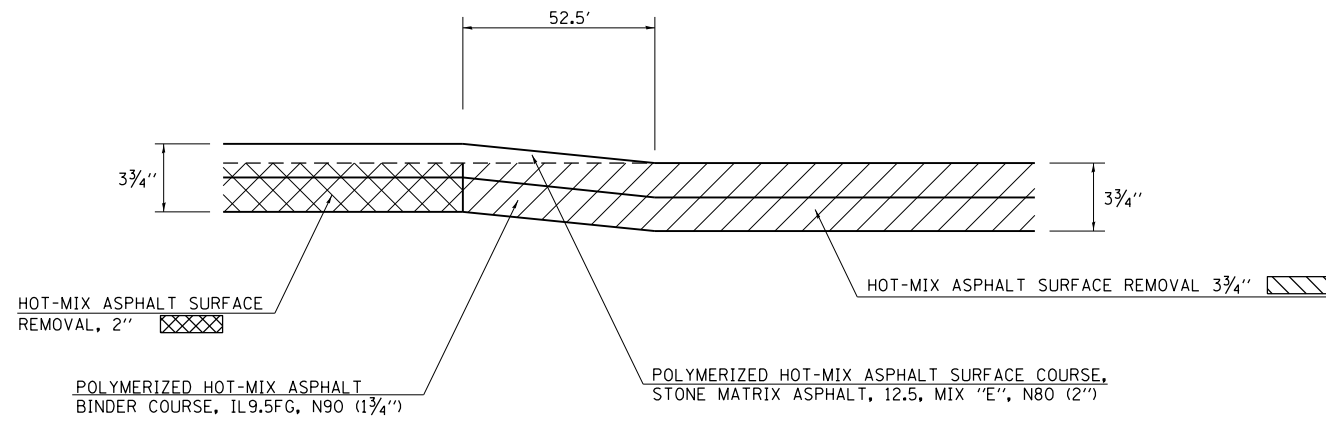

**MILLING TRANSITION DETAIL**

STA. 279+12 TO STA. 279+35 (US 51 NB)  
 STA. 282+36 TO STA. 282+59 (US 51 NB & SB)

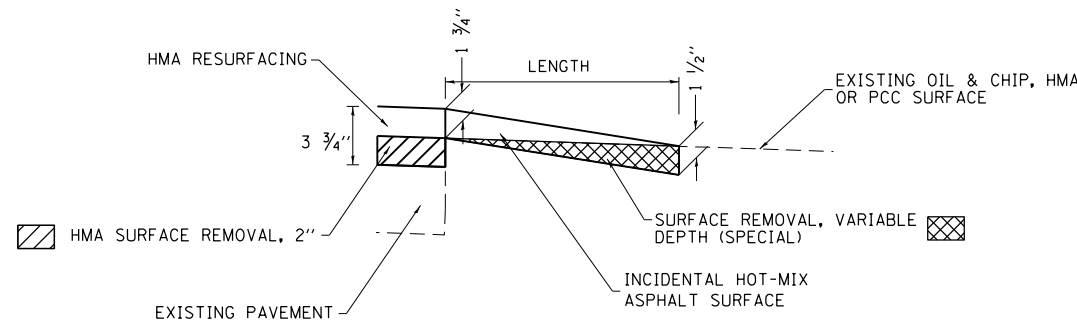

**PRA MILLING & PAVING DETAIL**

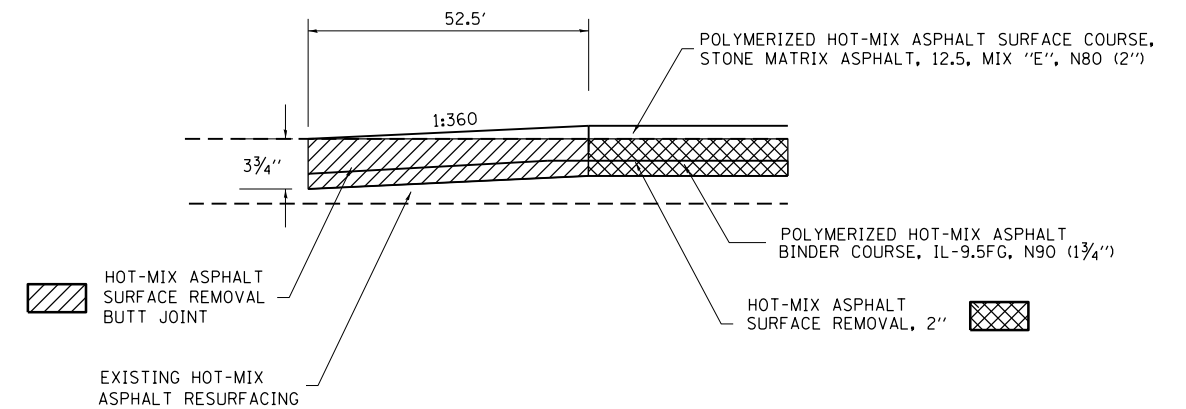

**BUTT JOINT DETAIL**

STA. 212+84 TO STA. 213+35.5 (US 51 NB & SB)  
 STA. 278+79.5 TO STA. 279+35 (US 51 SB)  
 STA. 408+47.5 TO STA. 409+00 (US 51 NB & SB)  
 STA. 428+50 TO STA. 429+02.5 (US 51 NB & SB)  
 STA. 1716+21 TO STA. 1716+44 (US 51 NB & SB)

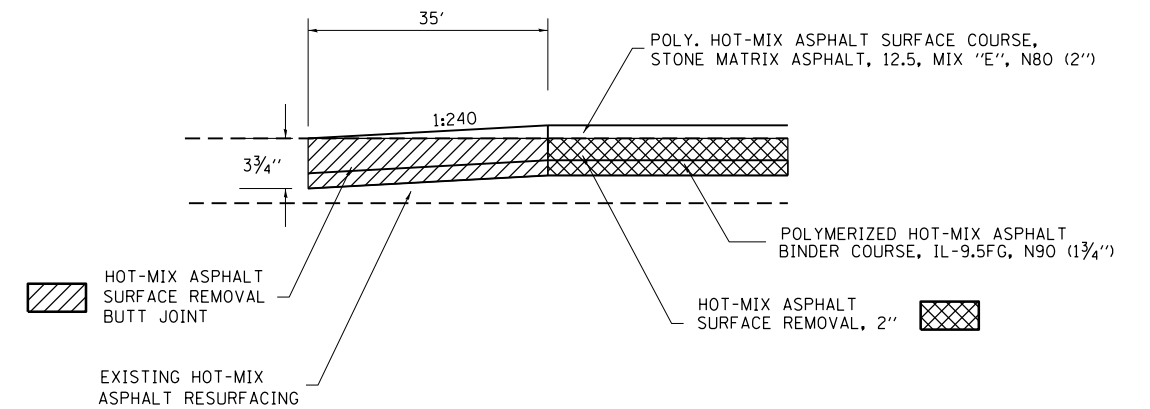

**BUTT JOINT DETAIL**

STA. 216+60 TO STA. 216+95 (RAMP A)  
 STA. 904+25 TO STA. 904+60 (RAMP D)  
 STA. 23+88 TO STA. 24+23 (RAMP E)  
 STA. 38+17 TO STA. 38+52 (RAMP F)

FILE NAME =	USER NAME = steffenmk	DESIGNED -	REVISED -	<b>STATE OF ILLINOIS DEPARTMENT OF TRANSPORTATION</b>	<b>CONSTRUCTION DETAILS</b>			F.A.P. RTE.	SECTION	COUNTY	TOTAL SHEETS	SHEET NO.
pww\planroom.dot\illinois.gov\PWIDOT\Documents\DOT Offices\District 7\Projects\74779\CADDData\CADSheets\DRAWN-shi-details.dgn		CHECKED -	REVISED -					322A	(46,47)RS-3, (58-20-1)RS-1	MACON	84	52
PLOT SCALE = 100.0000' / in.		DATE -	REVISED -		CONTRACT NO. 74779							
Default	PLOT DATE = 1/29/2020				SCALE: N/A	SHEET 1	OF 1	SHEETS	STA.	TO STA.	ILLINOIS	FED. AID PROJECT



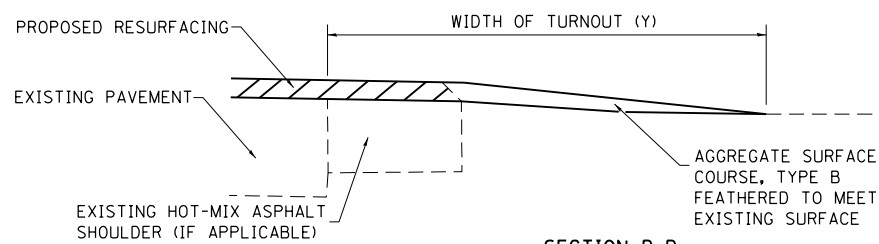
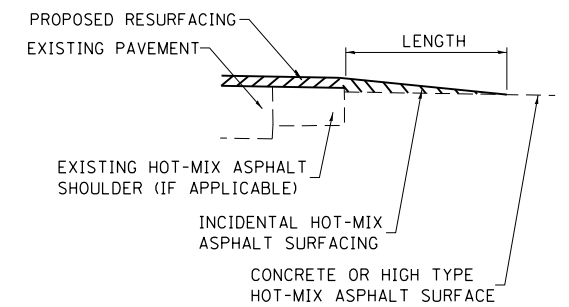
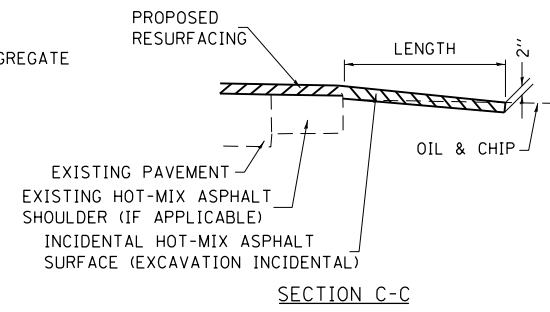
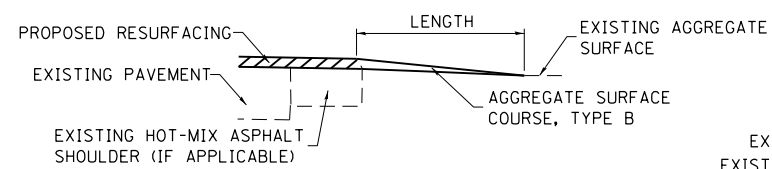
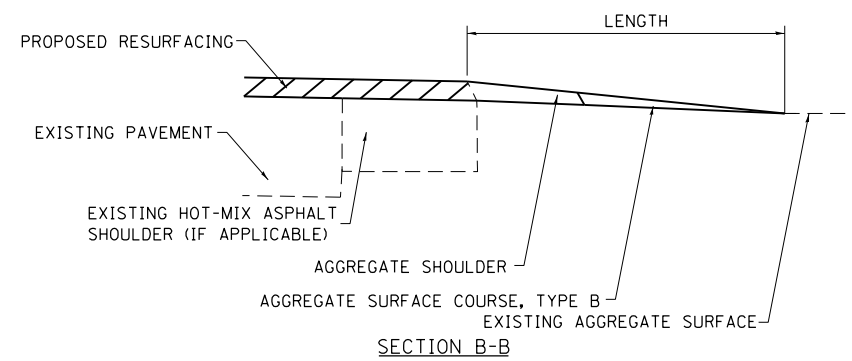
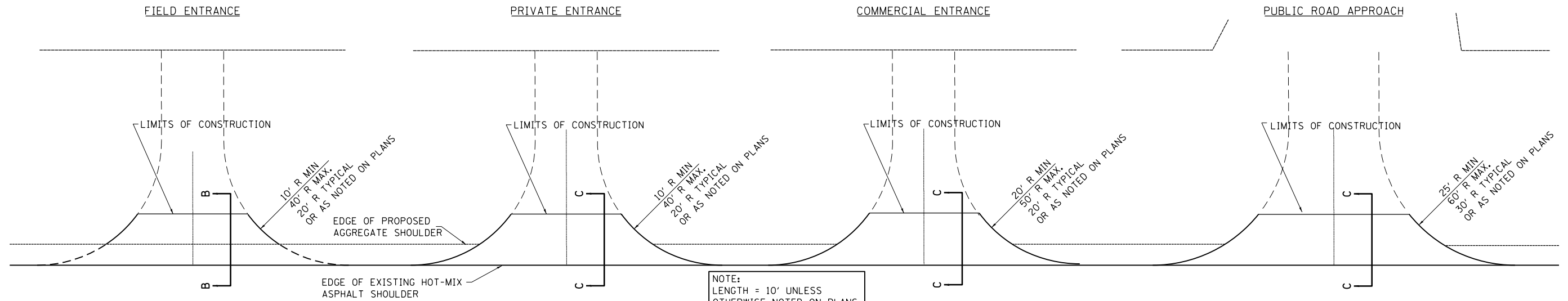

**TYPICAL SECTION AT MAILBOX TURNOUT**

NOTE: SEE STANDARD 406201 FOR MAILBOX TURNOUT DETAILS

**NOTES**

IF THERE IS NOT EXISTING HOT-MIX ASPHALT SHOULDER THEN THE ENTRANCE TAPER STARTS AT THE EDGE OF EXISTING PAVEMENT.

SIDE	STATION	TYPE	INCIDENTAL HOT-MIX ASPHALT SURFACING	
			TON	TON
<b>NORTHBOUND</b>				
RT	232+15	FE		2.4
RT	251+97	FE		1.4
RT	264+96	FE		1.3
RT	287+43	FE		1.4
RT	308+10	FE		1.3
RT	319+32	FE		1.3
RT	332+91	FE		1.3
RT	380+62	FE		2.4
RT	392+11	FE		1.3
RT	445+20	FE		2.4
RT	1512+52	FE		1.3
RT	1532+20	FE		1.3
RT	1539+71	FE		1.3
	<b>NB TOTALS:</b>		0.0	20.7
<b>SOUTHBOUND</b>				
LT	332+94	FE		0.9
LT	392+11	FE		1.3
LT	406+00	FE		2.4
LT	1512+29	FE		1.3
LT	1532+20	FE		1.3
	<b>SB TOTALS:</b>		0.0	7.3
	<b>PROJECT TOTALS:</b>		0.0	28.0

SIDE	STATION	TYPE	INCIDENTAL HOT-MIX ASPHALT SURFACING	
			TON	TON

SIDE	STATION	TYPE	INCIDENTAL HOT-MIX ASPHALT SURFACING	
			TON	TON

SIDE	STATION	TYPE	INCIDENTAL HOT-MIX ASPHALT SURFACING	
			TON	TON

SIDE	STATION	TYPE	INCIDENTAL HOT-MIX ASPHALT SURFACING	
			TON	TON

FE=FIELD ENTRANCE PRA - PUBLIC ROAD APPROACH  
 PE=PRIVATE ENTRANCE MBT - MAILBOX TURNOUT  
 CE=COMMERCIAL ENTRANCE

FILE NAME =	USER NAME = steffenmk	DESIGNED - 08-03-99	REVISED - 03-13-07
pw:\planroom.dot\illinois.gov\PIDOT\Documents\IDOT Offices\District 7\Projects\74779\DRAWING\CADsheets\0774779-shd-details.dwg		CHECKED -	REVISED -
		DATE -	REVISED -

**STATE OF ILLINOIS  
DEPARTMENT OF TRANSPORTATION**

**RURAL ENTRANCE SCHEDULE AND MAILBOX TURNOUT DETAILS  
WITH SHOULDERS**

SCALE: N/A SHEET NO. 1 OF 1 SHEETS STA. TO STA.

F.A.P. RTE.	SECTION	COUNTY	TOTAL SHEETS	SHEET NO.
322A	(46,47)RS-3, (58-20-1)RS-1	MACON	84	54
CONTRACT NO. 74779				
FED. ROAD DIST. NO. ILLINOIS FED. AID PROJECT				

# STRUCTURE LOCATIONS

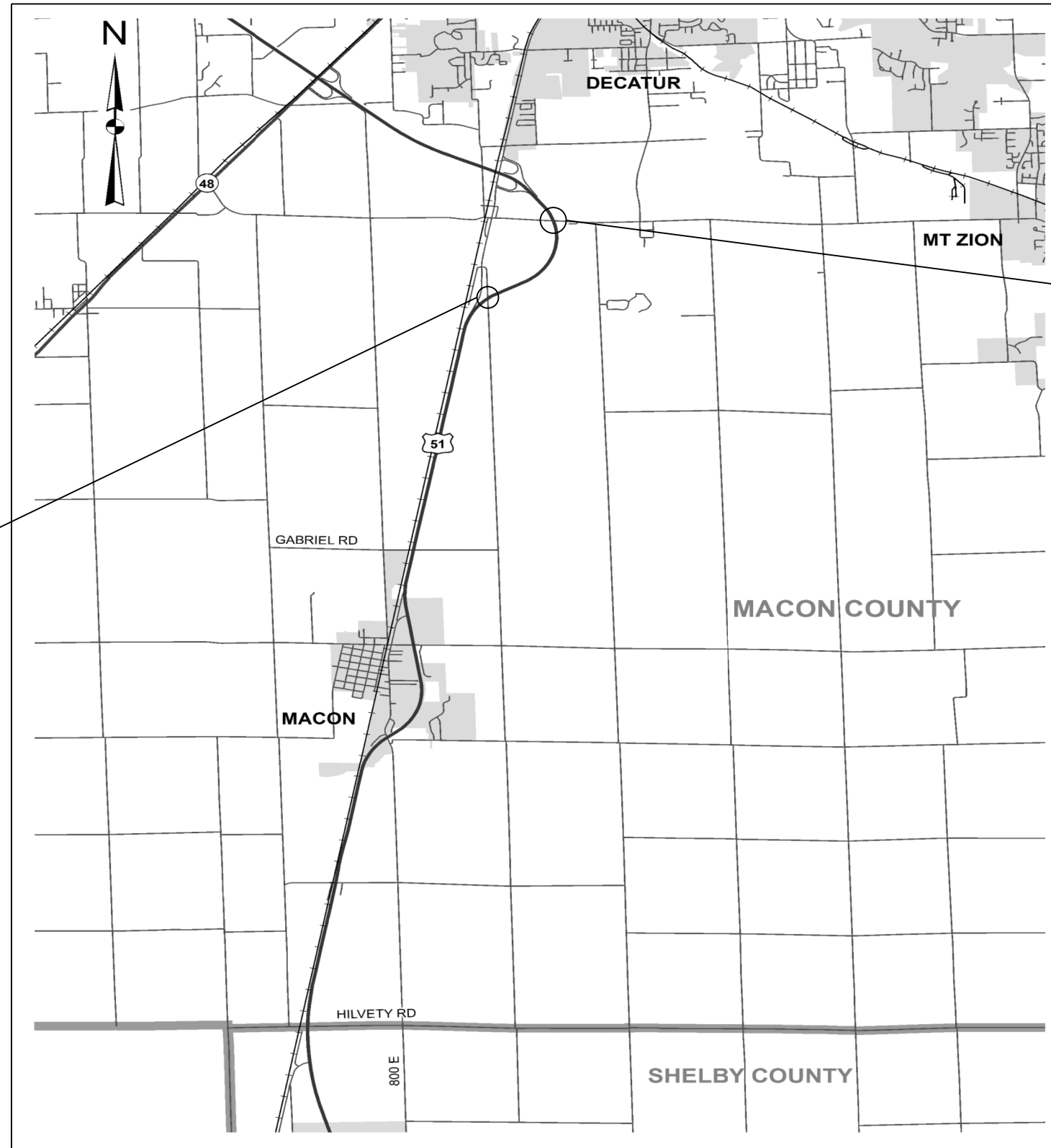

STRUCTURE NO. 058-0122 (RAMP E) &  
STRUCTURE NO. 058-0123 (RILEY RD.)

STRUCTURE NO. 058-0124 (CH 30 - ELWIN RD.)

MODEL: Default  
 FILE: \\nas01c.psu.edu\pub\baronm.d\at\illinois.gov\PI\DOT\Documents\DOT\_Offices\District\_7\Projects\74779\CAAD\BakCAD\Drawings\74779-struct\strloc.dgn

USER NAME = steffenmk	DESIGNED -	REVISED -
	DRAWN -	REVISED -
PLOT SCALE = 100,0000' / in.	CHECKED -	REVISED -
PLOT DATE = 1/29/2020	DATE -	REVISED -

**STATE OF ILLINOIS  
DEPARTMENT OF TRANSPORTATION**

## STRUCTURE LOCATIONS

SCALE: SHEET OF SHEETS STA. TO STA.

F.A.P. RTE.	SECTION	COUNTY	TOTAL SHEETS	SHEET NO.
322A	(46,47)RS-3, (58-20-1)RS-1	MACON	84	55
CONTRACT NO. 74779				
		ILLINOIS FED. AID PROJECT		

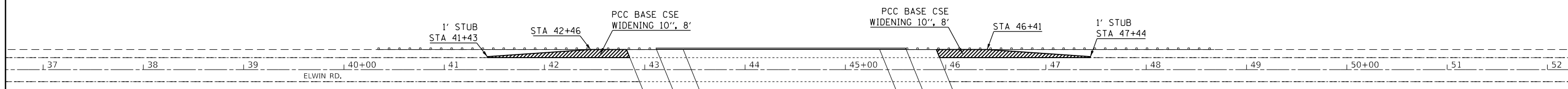
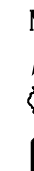

MODEL: Default  
 FILE: Model: p:\pub\baronm.dwg  
 PROJECT: 74779\CAAD\baronm.dwg  
 OFFICE: IDT  
 DATE: 1/29/2020

USER NAME = steffenmk	DESIGNED -	REVISED -
	DRAWN -	REVISED -
PLOT SCALE = 100,0000' / in.	CHECKED -	REVISED -
PLOT DATE = 1/29/2020	DATE -	REVISED -

**STATE OF ILLINOIS  
 DEPARTMENT OF TRANSPORTATION**

**PRE-STAGE CONSTRUCTION  
 S.N. 058-0124**

SCALE: SHEET OF SHEETS STA. TO STA.

F.A.P. RTE.	SECTION	COUNTY	TOTAL SHEETS	SHEET NO.
322A	(46,47)RS-3, (58-20-1)RS-1	MACON	84	56
CONTRACT NO. 74779			ILLINOIS FED. AID PROJECT	



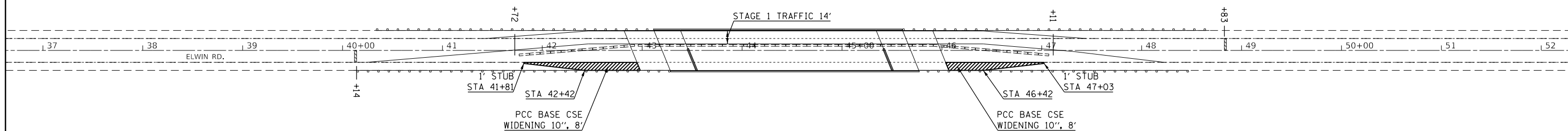
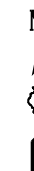

MODEL: Default  
 FILE: Model: P:\pub\lanroom.dwg  
 PROJECT: 74779\CAAD\Drawings\DOT\_Offices\Drawings\74779\74779-01-01.dwg

USER NAME = steffenmk	DESIGNED -	REVISED -
	DRAWN -	REVISED -
PLOT SCALE = 100,0000' / in.	CHECKED -	REVISED -
PLOT DATE = 1/29/2020	DATE -	REVISED -

**STATE OF ILLINOIS**  
**DEPARTMENT OF TRANSPORTATION**

**STAGE 1 CONSTRUCTION**  
**S.N. 058-0124**

SCALE: SHEET OF SHEETS STA. TO STA.

F.A.P. RTE.	SECTION	COUNTY	TOTAL SHEETS	SHEET NO.
322A	(46,47)RS-3, (58-20-1)RS-1	MACON	84	57
CONTRACT NO. 74779			ILLINOIS FED. AID PROJECT	



**EXISTING STRUCTURE: SN 058-0122**

Constructed in 1995, the existing structure consists of two spans of p.p.c. I beams and concrete superstructure deck spanning vaulted concrete abutments on concrete piles and concrete pier on a spread footing without piles. The existing structure measures 300'-0" back to back of approach bents and 43'-2"± out to out of the deck.

The Contractor shall remove and dispose of portions of the existing structure in accordance with Section 501 of the Standard Specifications.

The existing roadway will be closed to traffic during the construction.

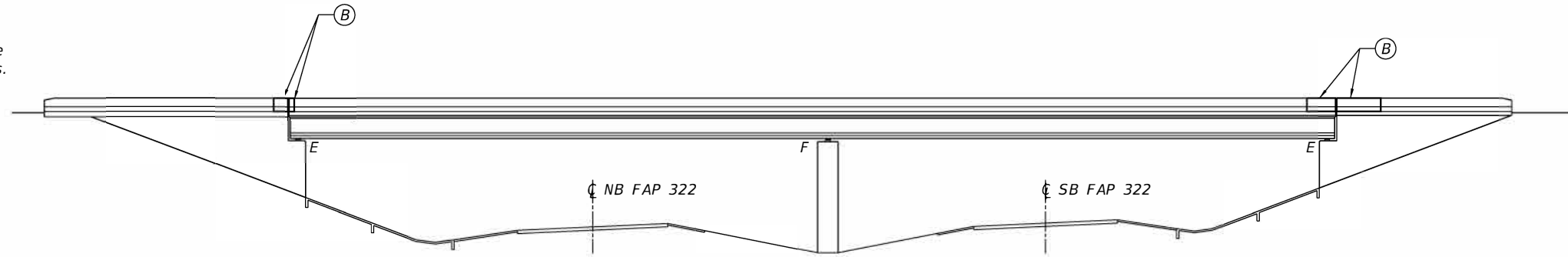

**ELEVATION**

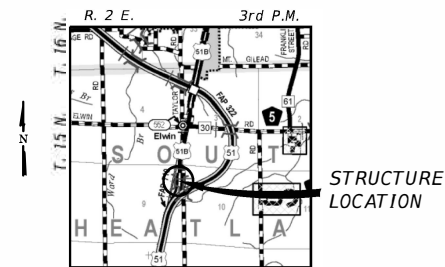

**LOCATION SKETCH**

**INDEX OF SHEETS**

1. General Plan and Elevation
2. General Notes and Bill of Material
3. Expansion Joint Replacement Details
4. Expansion Joint Replacement Details
5. Preformed Joint Strip Seal
6. Parapet Repair Details
7. Bar Splicer Assembly and Mechanical Splicer Details

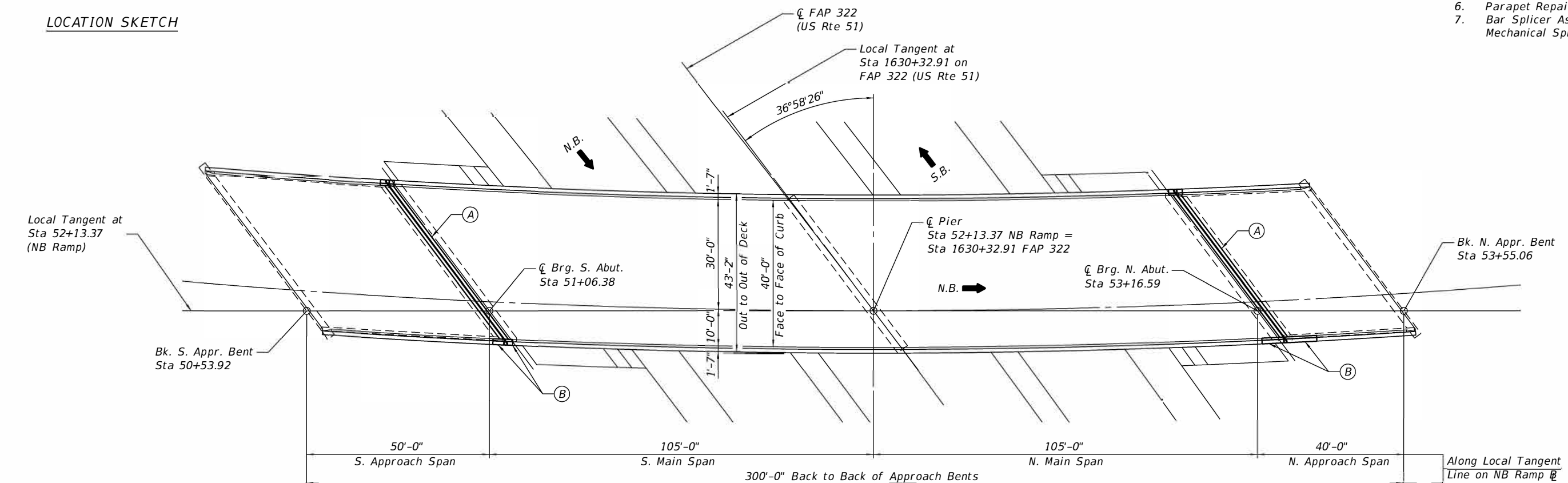

**PLAN**



- (A) Remove Existing Neoprene Expansion Joint and Install Preformed Strip Seal
- (B) Remove and Replace portion of Existing Parapet

**GENERAL PLAN & ELEVATION  
NORTH BOUND RAMP E  
OVER FAP 322 (US RTE 51)  
SECTION 58-20-1-HB  
MACON COUNTY  
STATION 52+13.37  
STRUCTURE NO. 058-0122**

*Bradley G. Hummert* Date: 1/13/20  
**Bradley G. Hummert**  
 Licensed Structural Engineer  
 in Illinois No. 081-005428 Expires: November 30, 2020

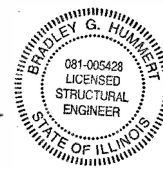

FILE NAME = H:\7322_IDOT_D7_Var\7322_07_W07_74779_US51_BridgeRepairPlans\058-0122\Merged Files\0580122_74779_01_gpel.dgn	DESIGNED -	REVISOR -	SCALE: 1" = 30'	STATE OF ILLINOIS DEPARTMENT OF TRANSPORTATION	GENERAL PLAN AND ELEVATION	SCALE: 1" = 30'	SHEET 1 OF 7 SHEETS	STA. TO STA.	F.A.P.	SECTION	COUNTY	TOTAL SHEETS	SHEET NO.
HMG ENGINEERS, INC. 9360 HOLY CROSS LANE BREESE, ILLINOIS 62230 (618) 526-9611	USER NAME = klauk	DRAWN -	REVISOR -						322	(46,47)RS-3 (58-20-1)RS-1	MACON	84	59
PLOT DATE = 1/28/2020	CHECKED -	REVISOR -		CONTRACT NO. 74779					ILLINOIS FED. AID PROJECT				

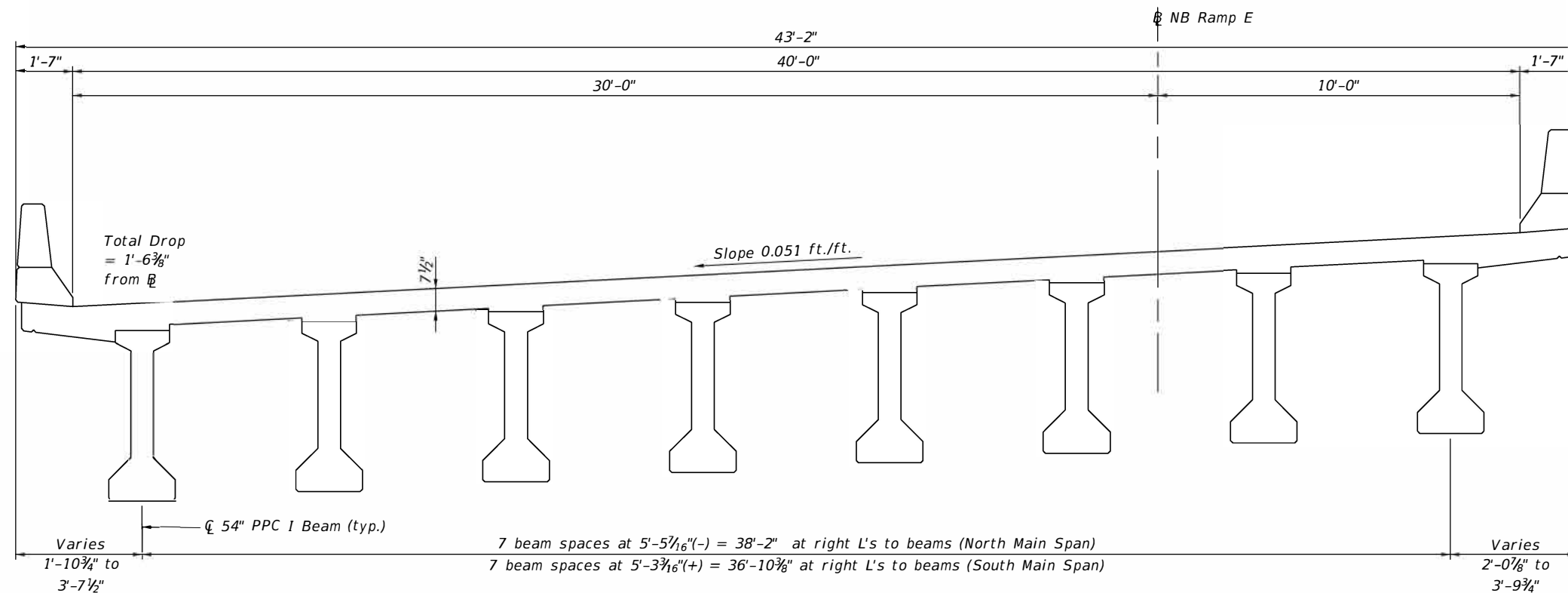

EXISTING CROSS SECTION

GENERAL NOTES

Plan dimensions and details relative to existing plans are subject to nominal construction variations. The Contractor shall field verify existing dimensions and details affecting new construction and make necessary approved adjustments prior to construction or ordering of materials. Such variations shall not be cause for additional compensation for a change in scope of the work, however, the Contractor will be paid for the quantity actually furnished at the unit price bid for the work.

Reinforcement bars designated (E) shall be epoxy coated.

Prior to pouring the new concrete deck, all heavy or loose rust, loose mill scale, and other loose or potentially detrimental foreign material shall be removed from the surfaces in contact with concrete. Tightly adhered paint may remain unless otherwise noted. Removal shall be accomplished by methods that will not damage the steel and the cost will be included in the pay item covering removal of the existing concrete.

Existing reinforcement bars extending into the removal area shall be cleaned, straightened and incorporated into the new construction. Any reinforcement bars that are damaged during concrete removal shall be replaced with an approved bar splicer or anchorage system. Cost included with Concrete Removal.

Joint openings shall be adjusted according to Article 520.04 of the Standard Specifications when the deck is poured at an ambient temperature other than 50° F.

The provided quantity of Deck Slab Repair (Partial) is intended to be used to repair any unsound areas in the bridge deck discovered during construction of the Expansion Joints. Deck slab areas to be repaired shall be designated by the Engineer, and marked on the as-built plans.

TOTAL BILL OF MATERIAL

ITEM	UNIT	QUANTITY
Concrete Removal	Cu Yd	7.3
Concrete Superstructure	Cu Yd	7.3
Reinforcement Bars, Epoxy Coated	Pound	1,700
Preformed Joint Strip Seal	Foot	110
Deck Slab Repair (Partial)	Sq Yd	5
Mechanical Splicers	Each	20

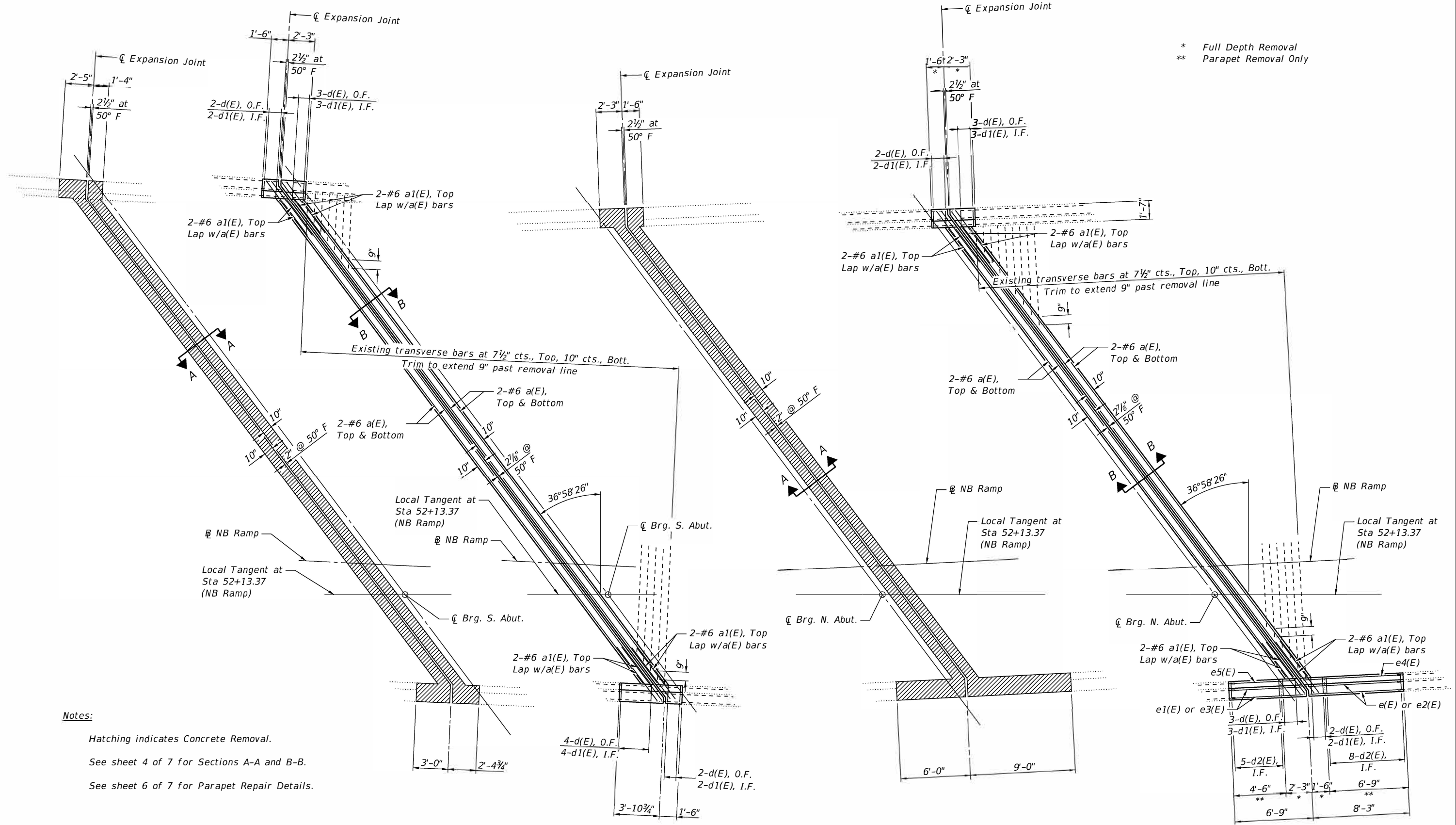

\* Full Depth Removal  
 \*\* Parapet Removal Only

**Notes:**  
 Hatching indicates Concrete Removal.  
 See sheet 4 of 7 for Sections A-A and B-B.  
 See sheet 6 of 7 for Parapet Repair Details.

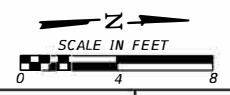

FILE NAME = H:\7322_IDOT_D7_Var\7322_07_W07_74779_US51_BridgeRepairPlans\058-0122\Merged Files\0580122_74779_03.EJ plan.dgn <b>HMG ENGINEERS, INC.</b> 9360 HOLY CROSS LANE BREESE, ILLINOIS 62230 (618) 526-9611		USER NAME = klaux PLOT SCALE = 8.0000' / 1"	DESIGNED - DRAWN - CHECKED -	REVISED - REVISED - REVISED - REVISED -	<b>STATE OF ILLINOIS</b> <b>DEPARTMENT OF TRANSPORTATION</b>	<b>EXPANSION JOINT REPLACEMENT DETAILS</b> <b>STRUCTURE NO. 058-0122</b>	F.A.P. 322 SECTION (46.47)RS-3 (58-20-1)RS-1 COUNTY MACON ILLINOIS FED. AID PROJECT	TOTAL SHEETS 84 SHEET NO. 61 CONTRACT NO. 74779
SCALE: SHEET 3 OF 7 SHEETS STA. TO STA.								

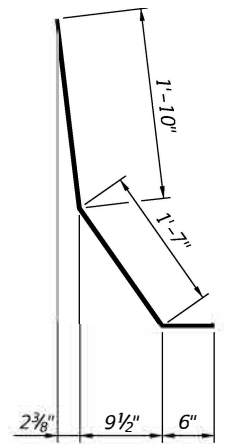
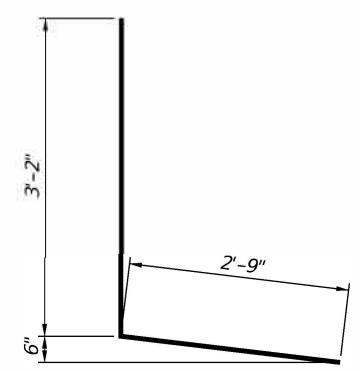
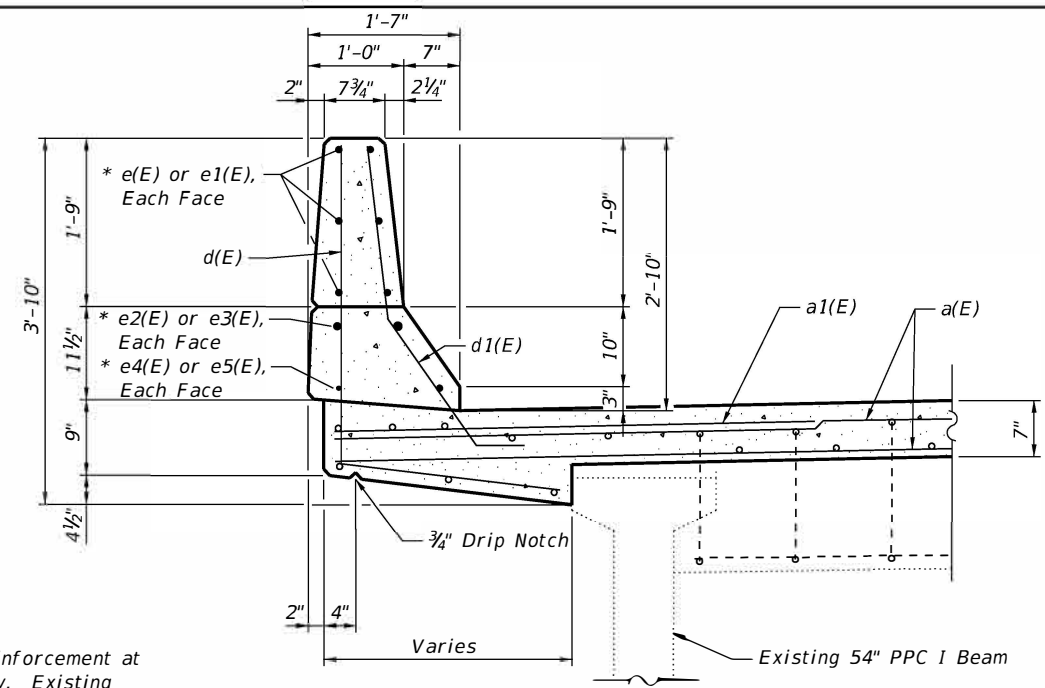

\* Replace horizontal reinforcement at northeast parapet only. Existing horizontal bars to remain at all other parapets.

**SECTION THRU PARAPET**  
(Areas of full Depth Removal)

**BAR d(E)**

**BAR d1(E)**

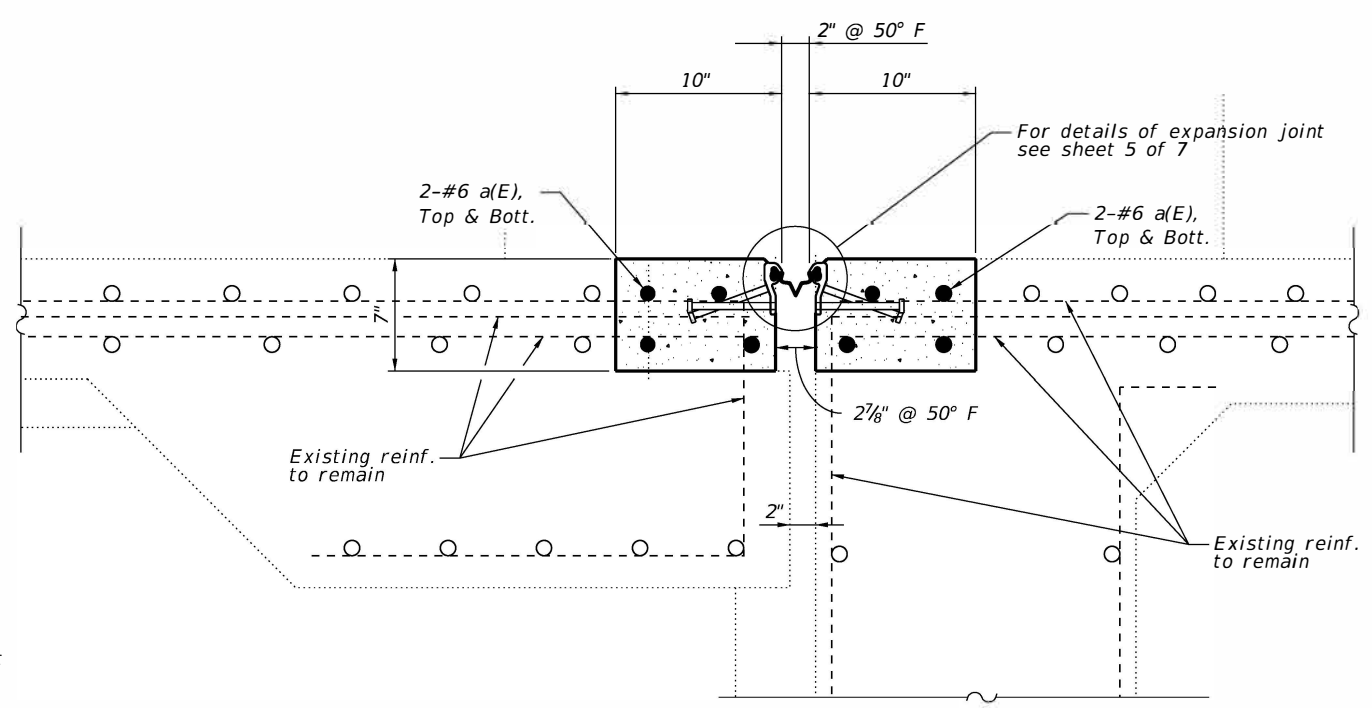
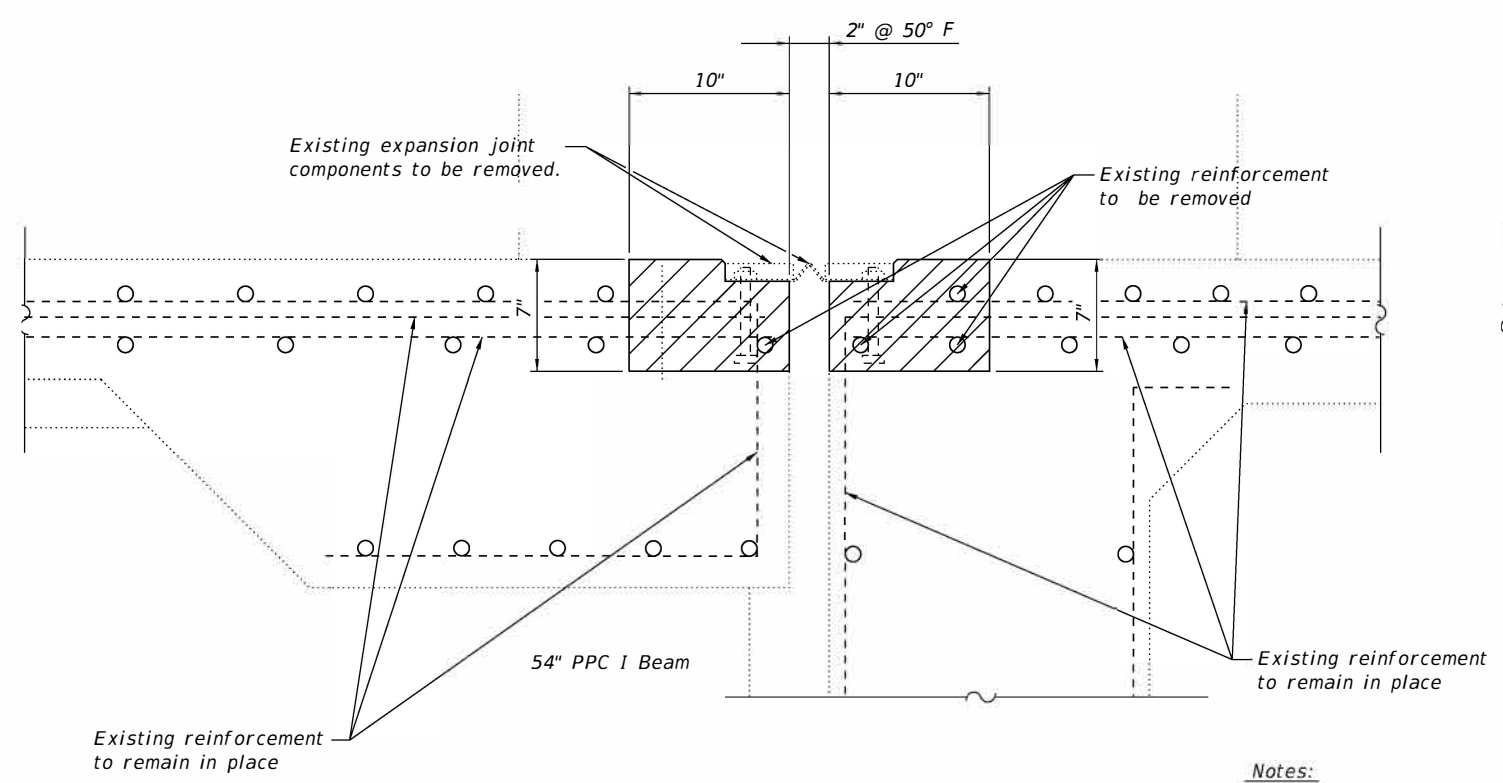

**Notes:**

Hatching indicates concrete removal.  
 Dimensions are at right angles to end of deck.  
 The Contractor shall use extreme care during concrete removal so as not to damage the PPC I-Beam. Any beam damaged shall be repaired or replaced at the Contractor's expense.

**SECTION A-A**

**SECTION B-B**

FILE NAME = H:\7322_IDOT_D7_Var\7322_07_W07_74779_US51_BridgeRepairPlans\058-0122\Merged Files\0580122_74779_04.EJ det.dgn		REVISED -	<b>STATE OF ILLINOIS</b> <b>DEPARTMENT OF TRANSPORTATION</b>		<b>EXPANSION JOINT REPLACEMENT DETAILS</b> <b>STRUCTURE NO. 058-0122</b>		F.A.P.	SECTION	COUNTY	TOTAL SHEETS	SHEET NO.			
<b>HMG</b> Engineers • Surveyors	HMG ENGINEERS, INC. 9360 HOLY CROSS LANE BREESE, ILLINOIS 62230 (618) 526-9611	USER NAME = klaux					DESIGNED -	REVISED -	322	(46.47)RS-3 (58-20-1)RS-1	MACON	84	62	
		PLOT SCALE = 1.0000' / in.					DRAWN -	REVISED -	CONTRACT NO. 74779					
		PLOT DATE = 1/28/2020					CHECKED -	REVISED -	ILLINOIS FED. AID PROJECT					
			SCALE:	SHEET 4 OF 7 SHEETS	STA.	TO STA.								

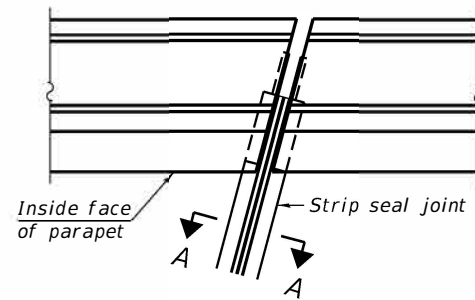

FOR SKEWS  $\leq 30^\circ$

PLAN AT PARAPET

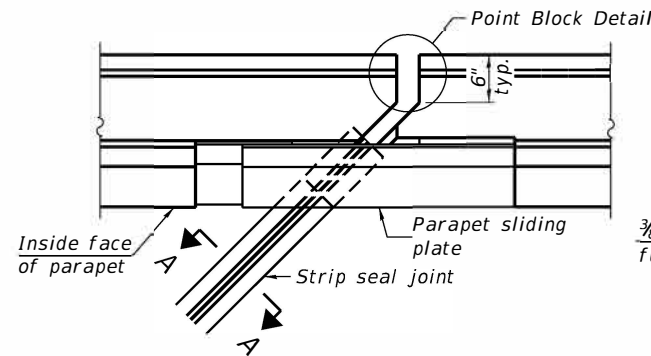

FOR SKEWS  $> 30^\circ$

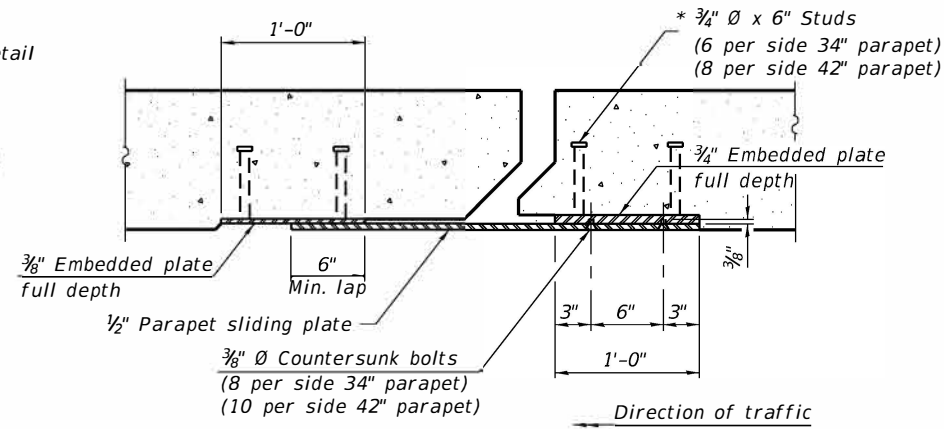

SECTION B-B

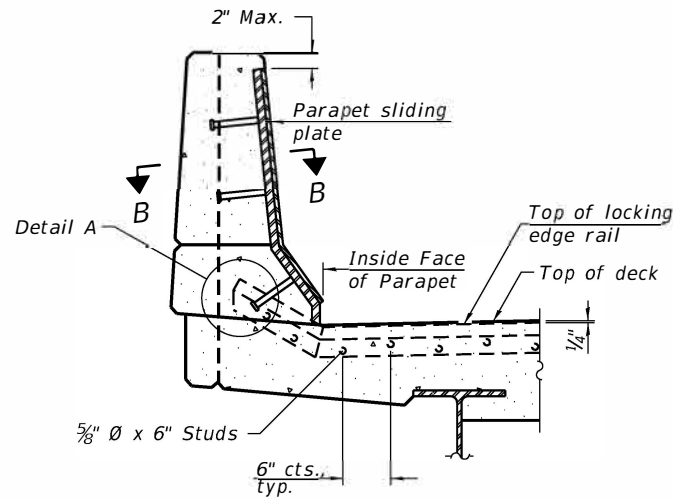

ELEVATION AT PARAPET

(Skews  $> 30^\circ$  shown. Skews  $\leq 30^\circ$  similar except as shown in plan view.)

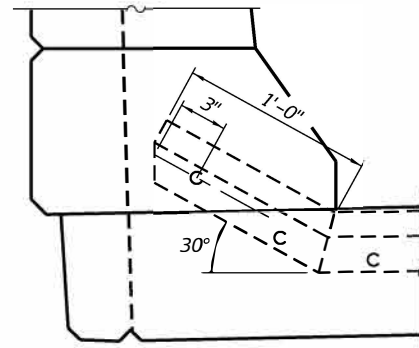

DETAIL A

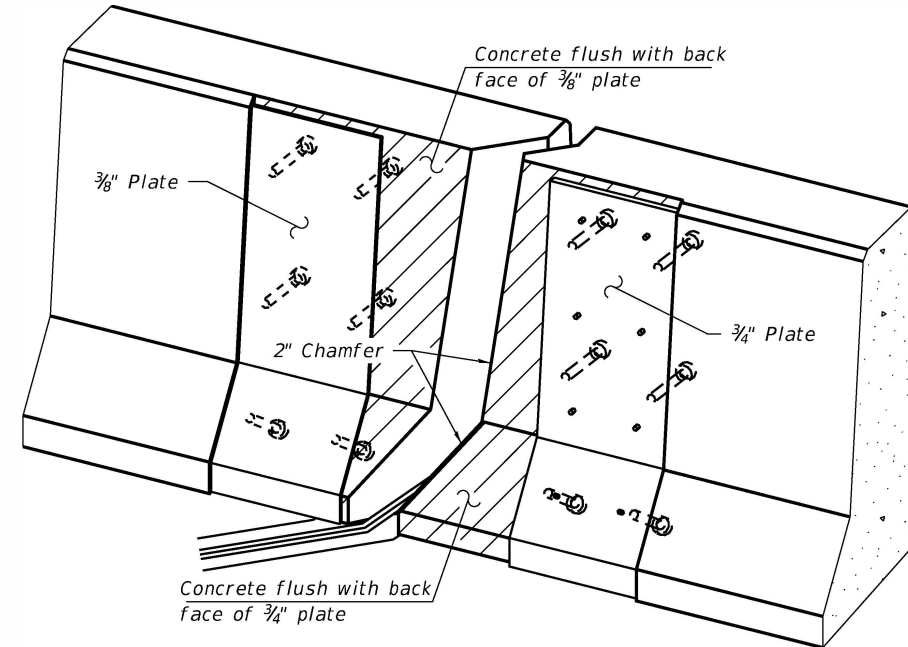

TRIMETRIC VIEW  
(Showing embedded plates only)

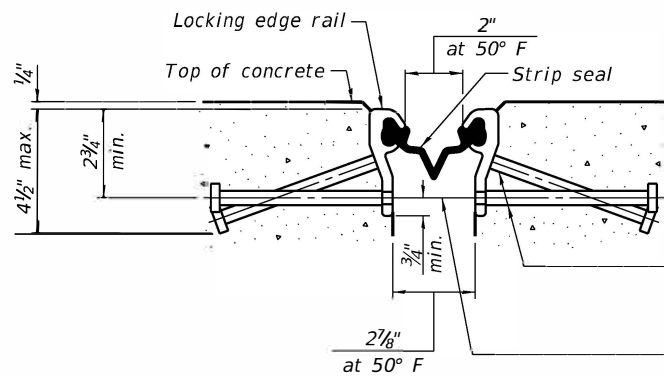

SHOWING ROLLED RAIL JOINT

\*  $5/8$ "  $\phi$  x 6" studs @ 6" cts. (alternate angled/bent studs with horizontal studs)

$3/8$ "  $\phi$  threaded rods in  $7/16$ "  $\phi$  holes at  $\pm 4$ "-0" cts. for holding the proper joint opening based on the temperature during the deck pour. Place to miss studs. All rods shall be burned, or sawed off flush with the plates after concrete is set.

SECTION A-A

\* Granular or solid flux filled headed studs conforming to Article 1006.32 of the Std. Specs., automatically end welded.

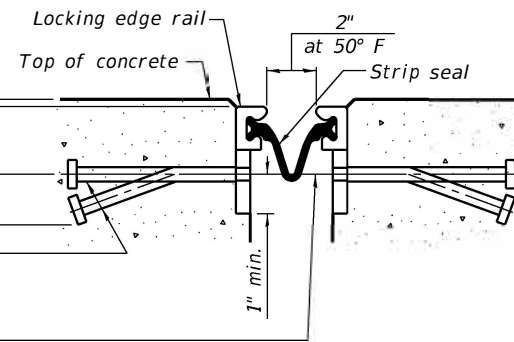

SHOWING WELDED RAIL JOINT

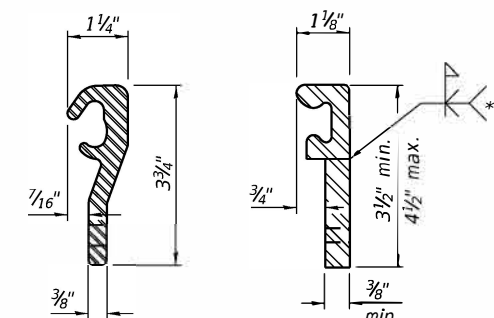

LOCKING EDGE RAILS

\*\* Back gouge not required if complete joint penetration is verified by mock-up.

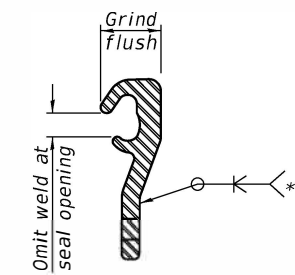

LOCKING EDGE RAIL SPLICE

The inside of the locking edge rail groove shall be free of weld residue. Rolled rail shown, welded rail similar.

BILL OF MATERIAL

Item	Unit	Total
Preformed Joint Strip Seal	Foot	110

EJ-SS

8-11-17

FILE NAME = H:\7322_IDOT_D7_Var\7322_07_W07_74779_US51_BridgeRepairPlans\058-0122\Merged Files\0580122_74779_05_expt.dgn	REVISIONS
HMG ENGINEERS, INC. 9360 HOLY CROSS LANE BREESE, ILLINOIS 62230 (618) 526-9611	DESIGNED - DRAWN - CHECKED -
USER NAME = klauk PLOT SCALE = 2.0000 ' / in. PLOT DATE = 1/28/2020	REVISED - REVISED - REVISED -

STATE OF ILLINOIS  
DEPARTMENT OF TRANSPORTATION

PREFORMED JOINT STRIP SEAL  
STRUCTURE NO. 058-0122

SCALE: SHEET 5 OF 7 SHEETS STA. TO STA.

F.A.P.	SECTION	COUNTY	TOTAL SHEETS	SHEET NO.
322	(46,47)RS-3 (58-20-1)RS-1	MACON	84	63
ILLINOIS FED. AID PROJECT			CONTRACT NO. 74779	

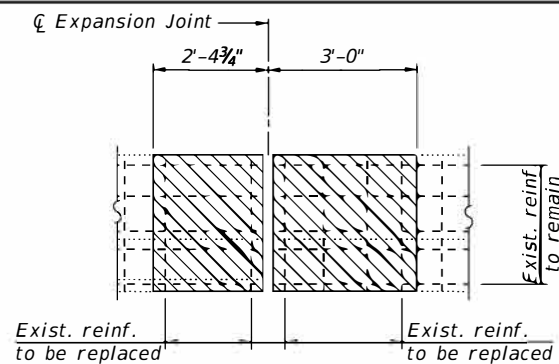

**EAST PARAPET ELEVATION - SOUTH END  
CONCRETE REMOVAL**

(Inside Elevation looking East)  
Hatched area indicates removal

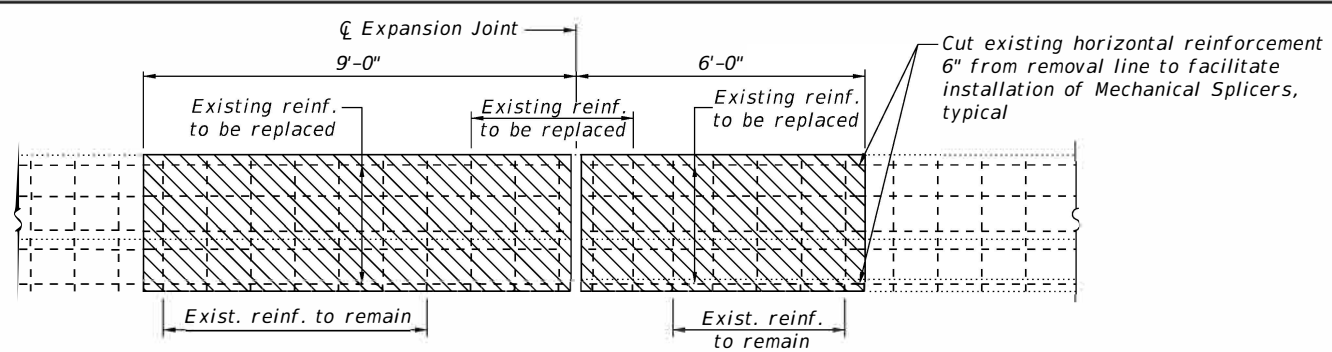

**EAST PARAPET ELEVATION - NORTH END  
CONCRETE REMOVAL**

(Inside Elevation looking East)  
Hatched area indicates removal

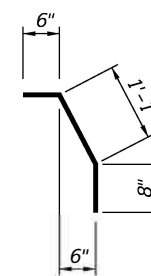

**BAR d2(E)**

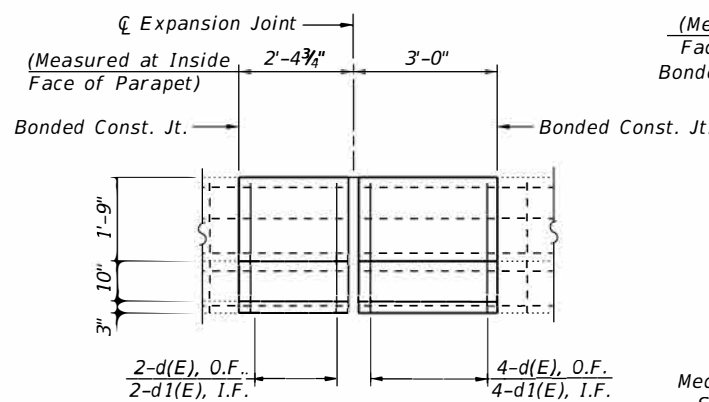

**EAST PARAPET ELEVATION - SOUTH END  
SUPERSTRUCTURE CONCRETE**

(Inside Elevation looking East)

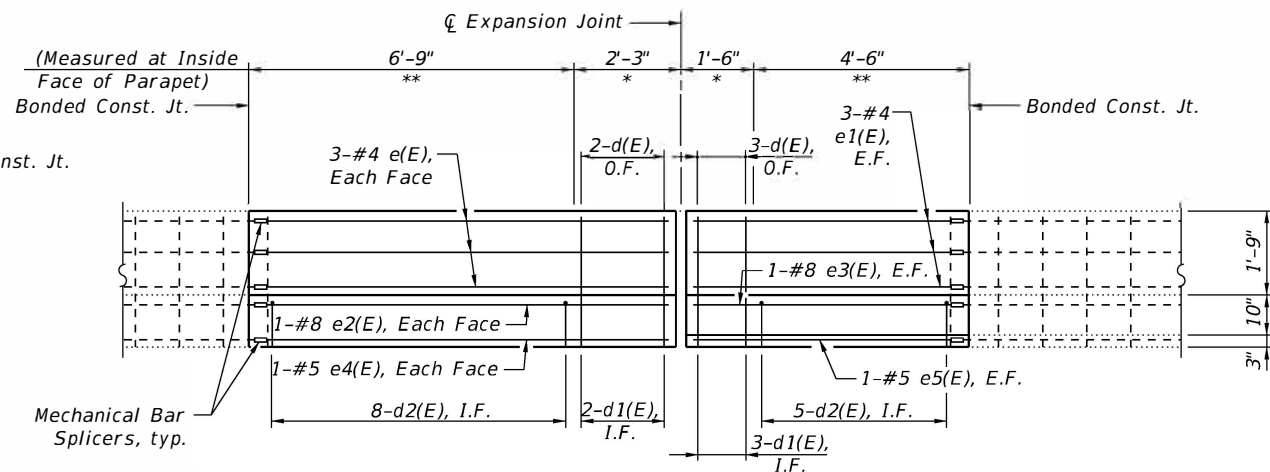

**EAST PARAPET ELEVATION - NORTH END  
SUPERSTRUCTURE CONCRETE**

(Inside Elevation looking East)

\* Full Depth Removal  
\*\* Parapet Removal Only

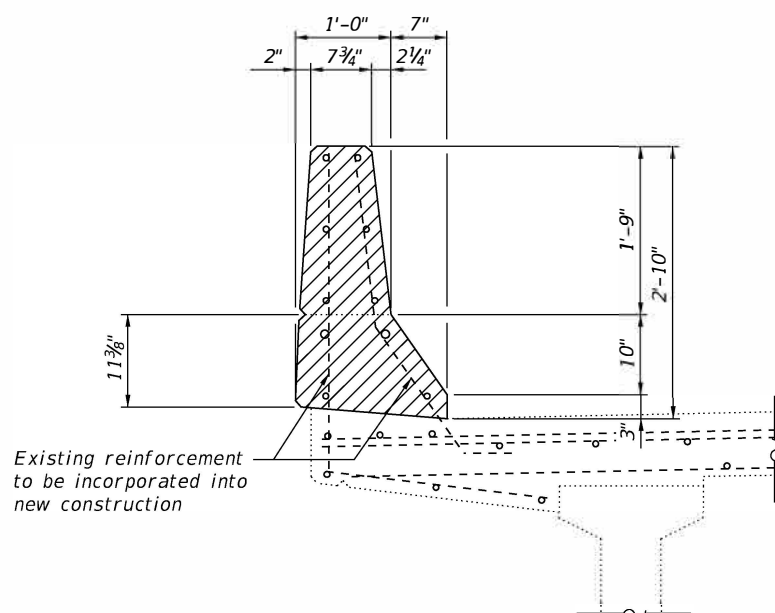

**SECTION THRU PARAPET  
CONCRETE REMOVAL**

Hatched area indicates removal  
(Areas of Parapet Removal only)

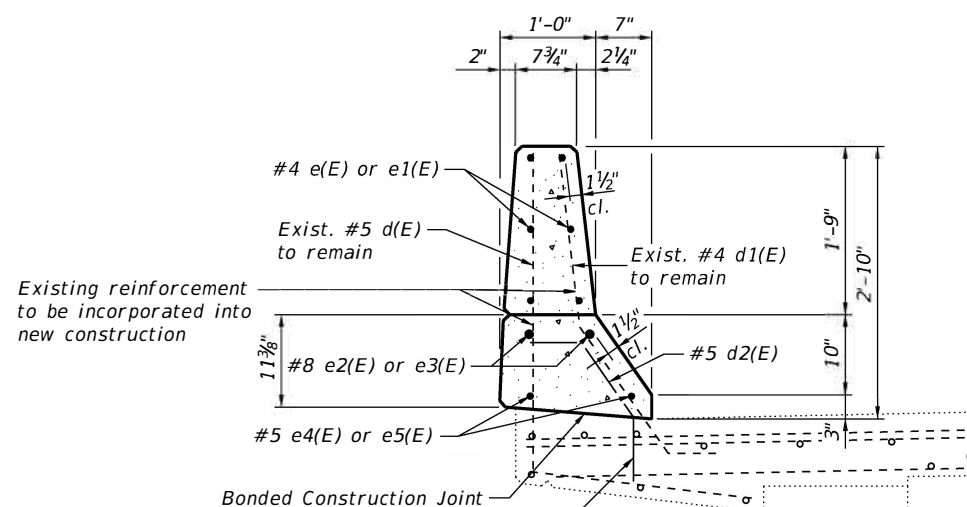

Epoxy grout d2(E) bars in front face of parapet between existing bars in 7 1/2" min. depth holes according to Article 584 of Standard Spec. (North Abutment Only)

**SECTION THRU PARAPET  
(Areas of Parapet Removal only)**

**BILL OF MATERIAL**

Bar	No.	Size	Length	Shape
a(E)	16	#6	5'3"-8"	—
a1(E)	16	#6	5'-6"	—
d(E)	21	#5	5'-11"	L
d1(E)	21	#4	3'-11"	L
d2(E)	13	#5	2'-3"	~
e(E)	6	#4	7'-5"	—
e1(E)	6	#4	5'-8"	—
e2(E)	2	#8	7'-5"	—
e3(E)	2	#8	5'-8"	—
e4(E)	2	#5	8'-2"	—
e5(E)	2	#5	5'-2"	—
Concrete Removal		Cu Yd	7.3	
Concrete Superstructure		Cu Yd	7.3	
Reinforcement Bars, Epoxy Coated		Pound	1,700	
Mechanical Splicers		Each	20	



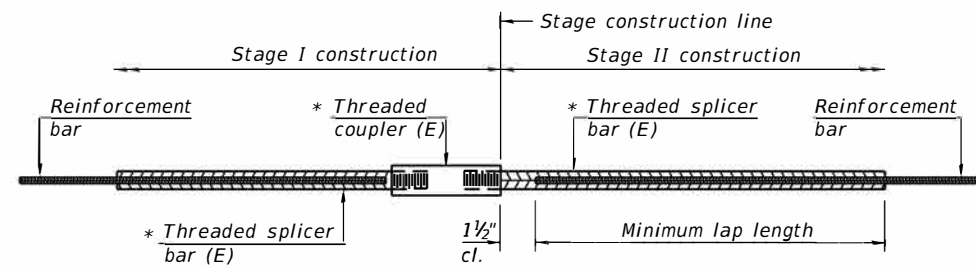

**STANDARD BAR SPLICER ASSEMBLY**

Threaded splicer bar length = min. lap length + 1 1/2" + thread length

\* Epoxy not required on Bar Splicer Assembly components used in conjunction with black bars.

Location	Bar size	No. assemblies required	Minimum lap length

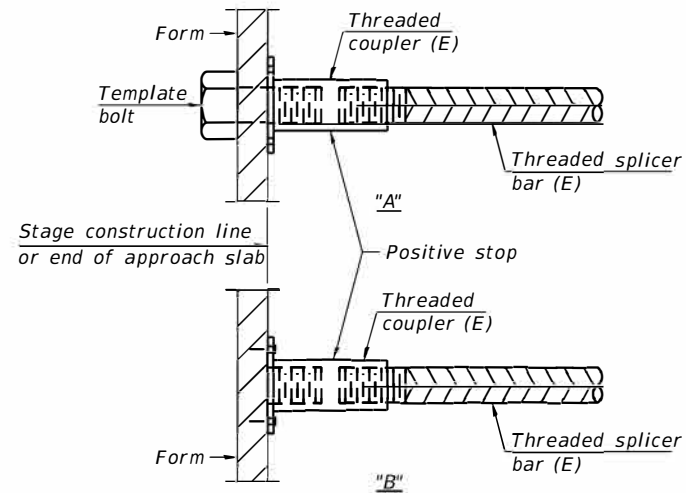

**INSTALLATION AND SETTING METHODS**

"A" : Set bar splicer assembly by means of a template bolt.

"B" : Set bar splicer assembly by nailing to wood forms or cementing to steel forms.

(E) : Indicates epoxy coating.

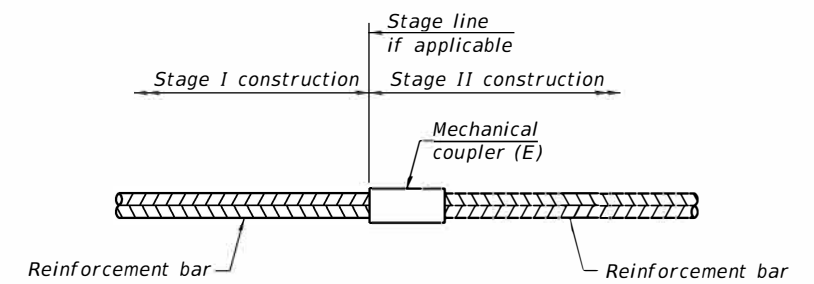

**STANDARD MECHANICAL SPLICER**

Location	Bar size	No. assemblies required
Parapet	#4	12
Parapet	#5	4
Parapet	#8	4

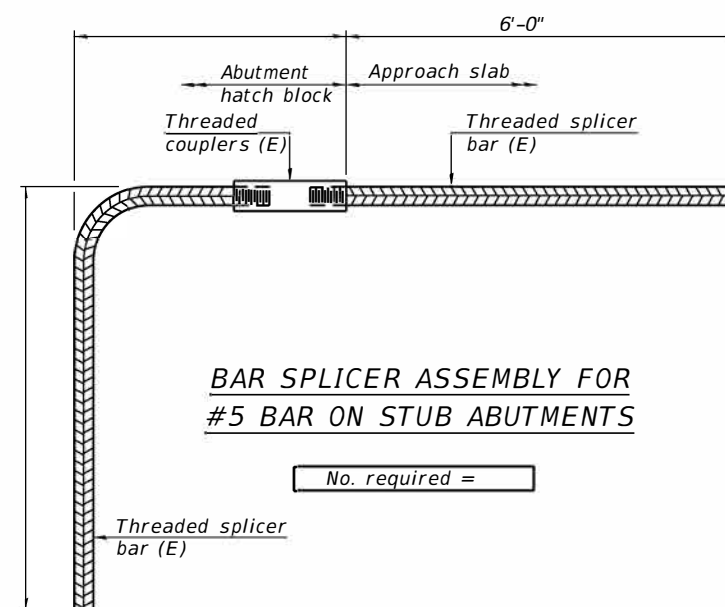

**BAR SPLICER ASSEMBLY FOR #5 BAR ON STUB ABUTMENTS**

No. required =

**NOTES**

Splicer bars shall be deformed with threaded ends and have a minimum 60 ksi yield strength.

All reinforcement shall be lapped and tied to the splicer bars. Bar splicer assemblies shall be epoxy coated according to the requirements for reinforcement bars. See Section 508 of the Standard Specifications.

See approved list of bar splicer assemblies and mechanical splicers for alternatives.

BSD-1 2-17-2017

**EXISTING STRUCTURE: SN 058-0123**

Constructed in 1995, the existing structure consists of two spans of p.p.c. I beams and concrete superstructure deck spanning vaulted concrete abutments on concrete piles and concrete pier on a spread footing without piles. The existing structure measures 285'-0" back to back of approach bents and 33'-2" out to out of the deck.

The existing roadway will be closed to traffic during the construction.

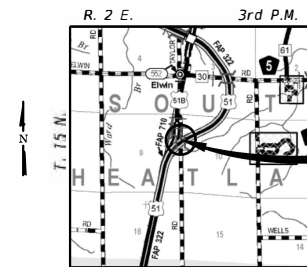

STRUCTURE LOCATION

LOCATION SKETCH

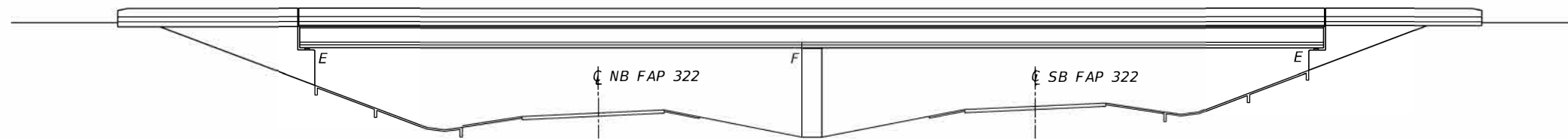

ELEVATION

**INDEX OF SHEETS**

1. General Plan and Elevation
2. General Notes and Bill of Material
3. Joint Repair Details

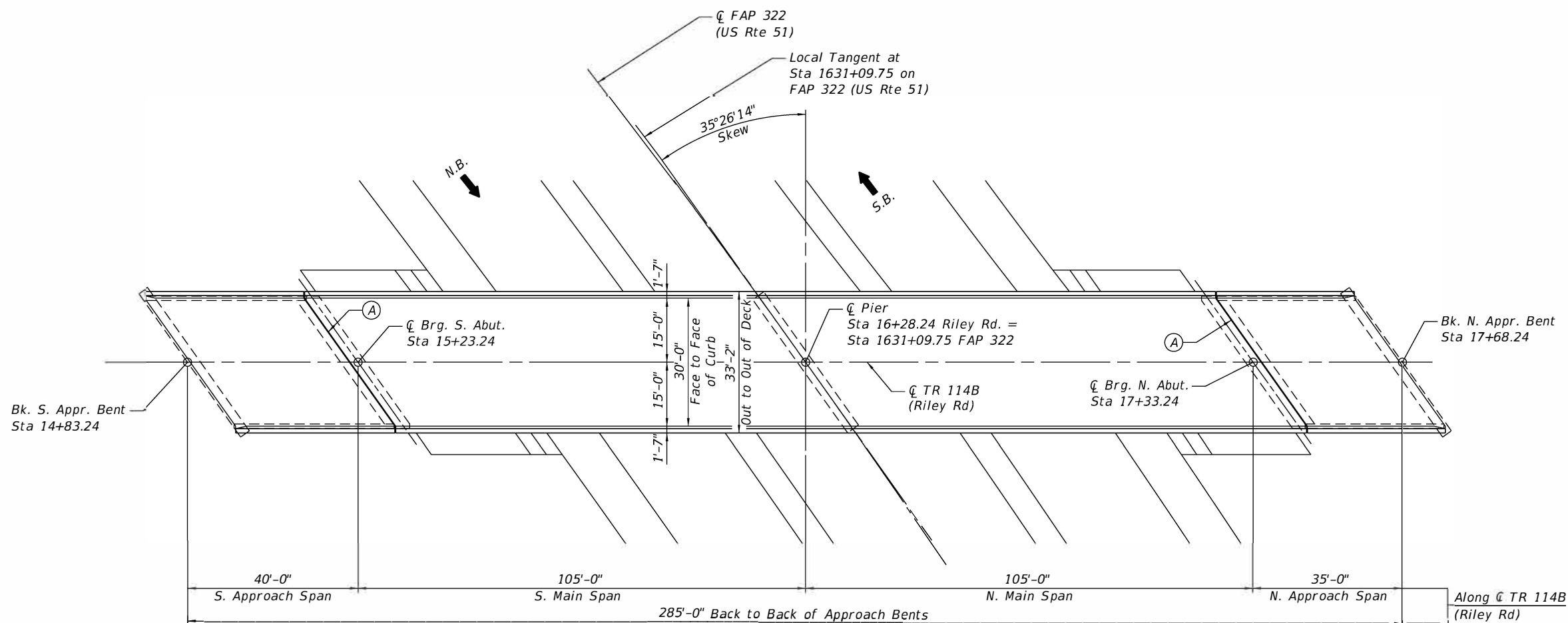

PLAN

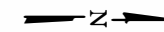
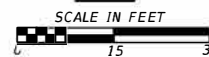

(A) Remove Existing Neoprene Expansion Joint and Install Polymer Concrete/Silicone Joint

*Bradley G. Hummert* Date: 1/13/20  
 Bradley G. Hummert  
 Licensed Structural Engineer  
 in Illinois No. 081-005428 Expires: November 30, 2020

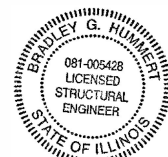

**GENERAL PLAN & ELEVATION**  
 TR 114B (RILEY ROAD) OVER  
 FAP 322 (US RTE 51)  
 SECTION 58-20-1-HB1  
 MACON COUNTY  
 STATION 16+28.24  
 STRUCTURE NO. 058-0123

FILE NAME = H:\7322_IDOT_D7_Var\7322_07_W07_74779_US51_BridgeRepairPlans\058-0123\Merged Files\0580123_74779_01_gpel.dgn	DESIGNED -	REVISD -	F.A.P.	SECTION	COUNTY	TOTAL SHEETS	SHEET NO.
HMG ENGINEERS, INC. 9360 HOLY CROSS LANE BREESE, ILLINOIS 62230 (618) 526-9611	USER NAME = kla.jux	REVI SED -	322	(46,47)RS-3 (58-20-1)RS-1	MACON	84	66
PLOT SCALE = 30.000' / in.	DRAWN -	REVI SED -	CONTRACT NO. 74779				
PLOT DATE = 1/28/2020	CHECKED -	REVISED -	ILLINOIS FED. AID PROJECT				
STATE OF ILLINOIS DEPARTMENT OF TRANSPORTATION			GENERAL PLAN AND ELEVATION				
SCALE:			SHEET 1 OF 3 SHEETS STA. TO STA.				

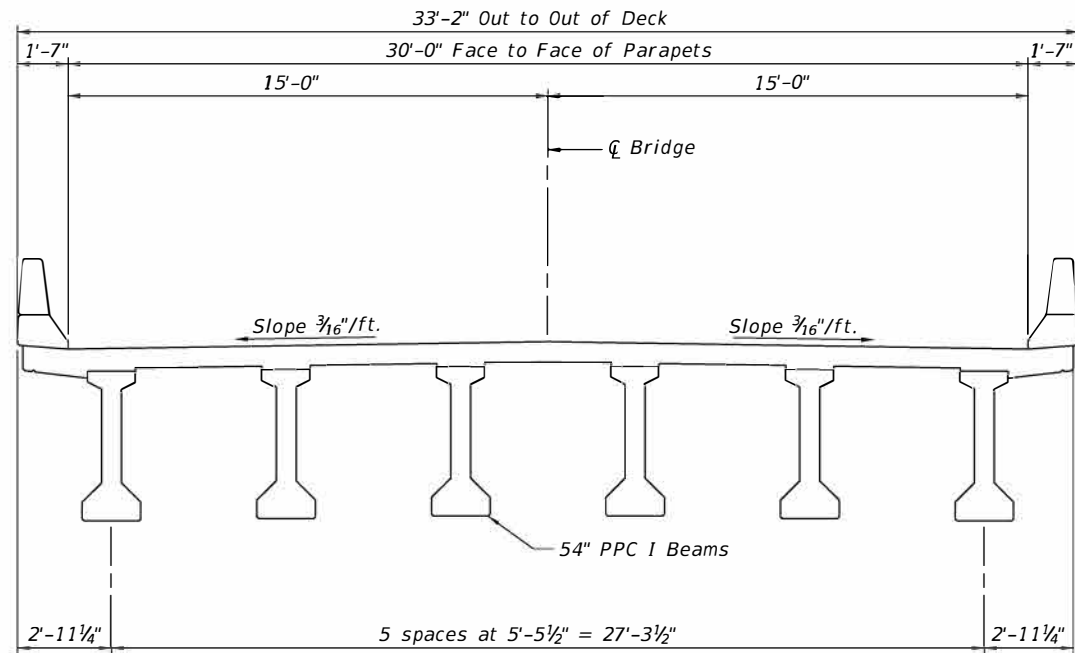

EXISTING CROSS SECTION

GENERAL NOTES

Plan dimensions and details relative to existing plans are subject to nominal construction variations. The Contractor shall field verify existing dimensions and details affecting new construction and make necessary approved adjustments prior to construction or ordering of materials. Such variations shall not be cause for additional compensation for a change in scope of the work, however, the Contractor will be paid for the quantity actually furnished at the unit price bid for the work.

Joint openings shall be adjusted according to Article 520.04 of the Standard Specifications when the deck is poured at an ambient temperature other than 50° F.

TOTAL BILL OF MATERIAL

ITEM	UNIT	QUANTITY
Silicone Joint Sealer, 2"	Foot	78
Polymer Concrete	Cu Ft	6.0

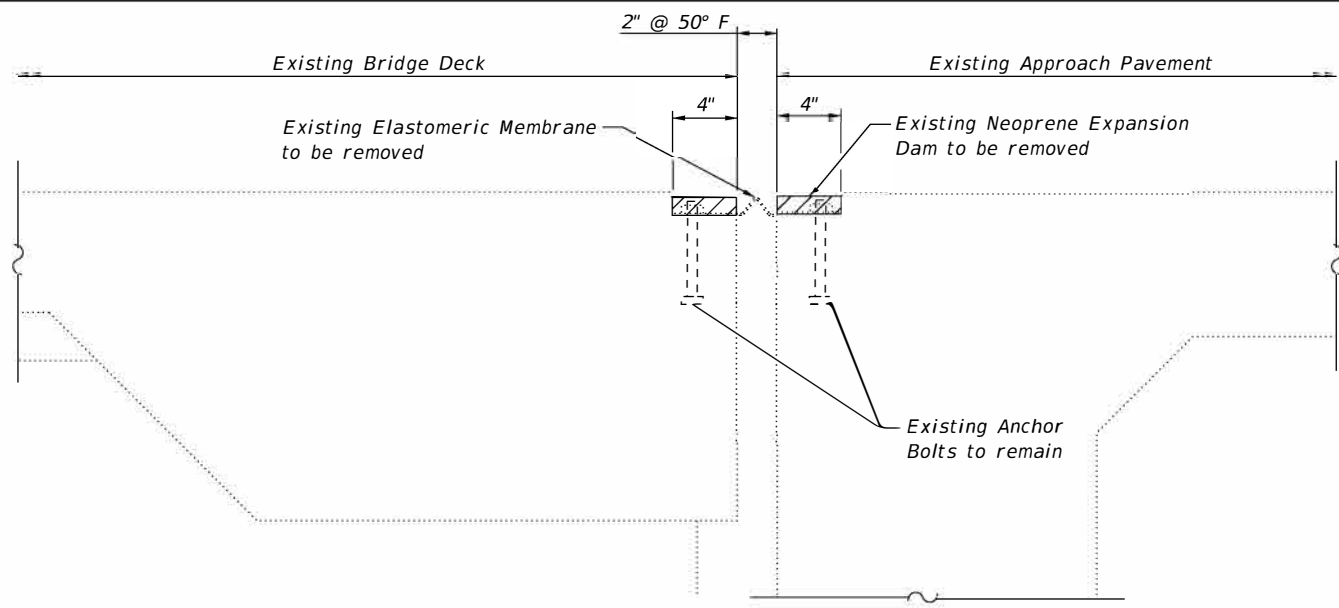

SECTION AT EXISTING JOINT

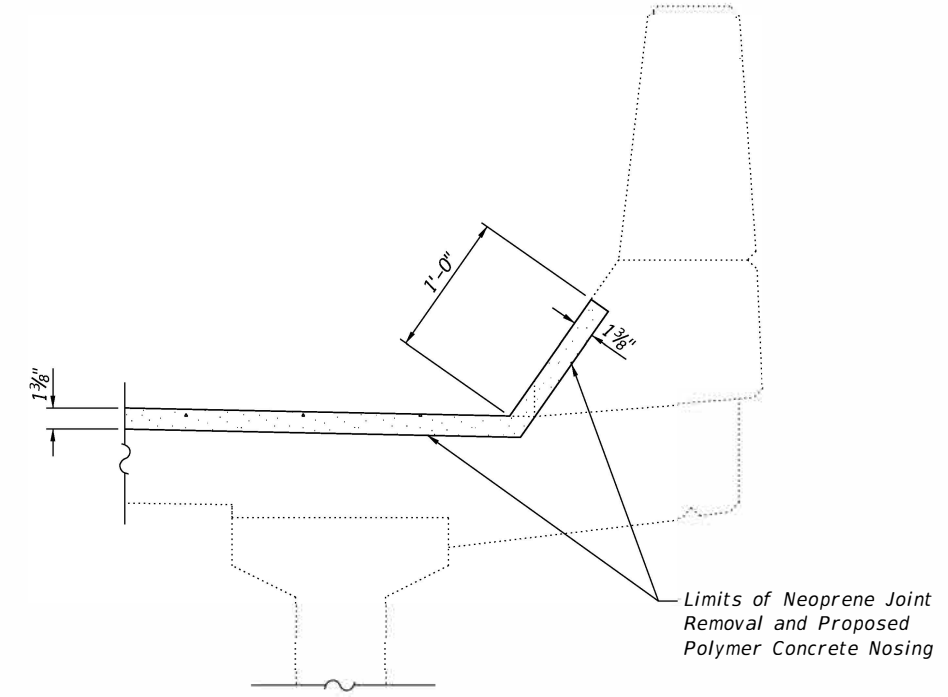

SECTION AT PARAPET  
POLYMER CONCRETE NOSING

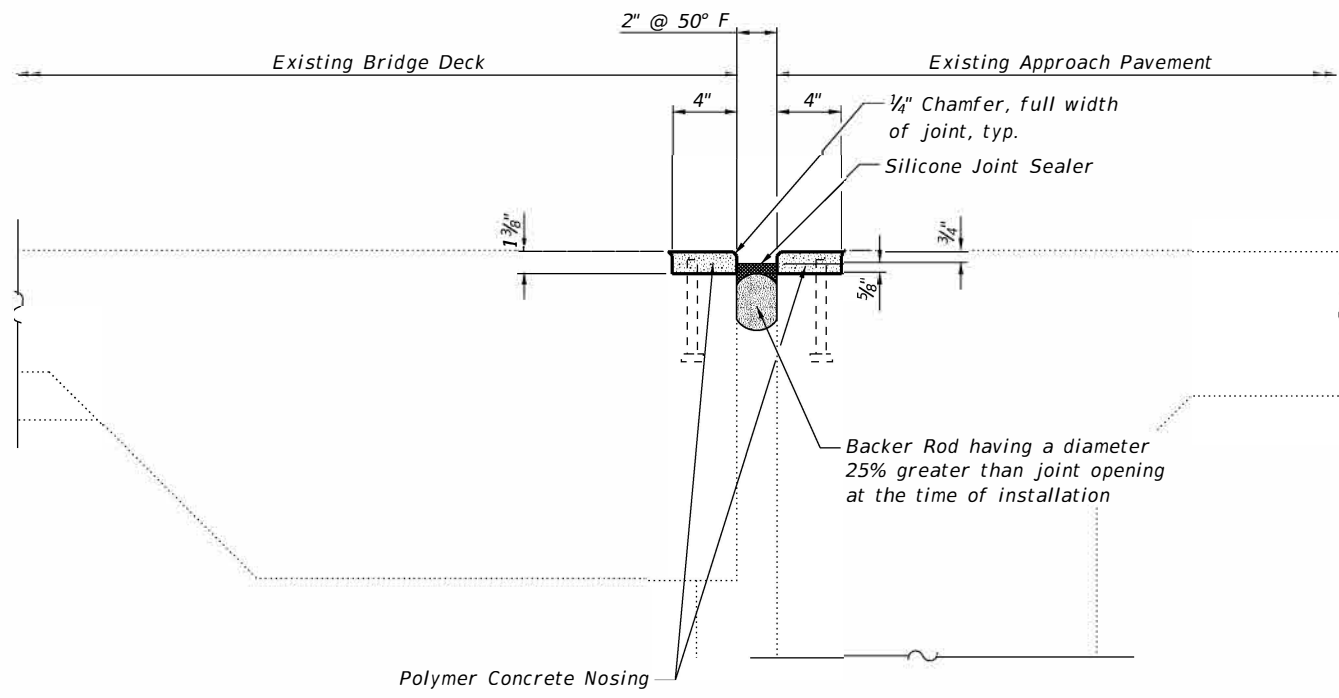

SECTION AT PROPOSED JOINT  
(At Right Angles to Joint)

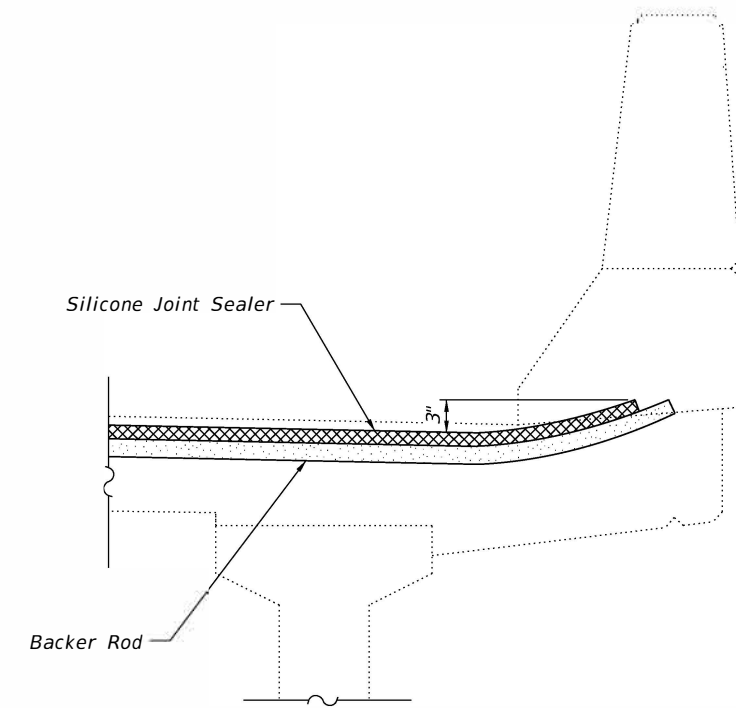

SECTION AT PARAPET  
SILICONE JOINT SEALER

**Notes:**

Remove existing neoprene expansion dam and replace with silicone joint sealer and polymer concrete nosing.

Removal of the existing neoprene expansion dam is included in the cost of Silicone Joint Sealer, 2".

FILE NAME = H:\17322_IDOT_D7_Var\17322_07_W07_74779_US51_BridgeRepairPlans\058-0123\Merged Files\0580123_74779_03_details.dgn	DESIGNED -	REVISOR -
USER NAME = klaux	DRAWN -	REVISIONS -
PLOT SCALE = 1/8"=1'-0"	CHECKED -	
PLOT DATE = 1/28/2007		

**STATE OF ILLINOIS  
DEPARTMENT OF TRANSPORTATION**

**JOINT REPAIR DETAILS  
STRUCTURE NO. 058-0123**

SCALE: SHEET 3 OF 3 SHEETS STA. TO STA.

F.A.P.	SECTION	COUNTY	TOTAL SHEETS	SHEET NO.
322	(46,47)RS-3 (58-20-1)RS-1	MACON	84	68
ILLINOIS FED. AID PROJECT			CONTRACT NO. 74779	



**EXISTING STRUCTURE: SN 058-0124**

Constructed in 1995, the existing structure consists of two spans of p.p.c. I beams and concrete superstructure deck spanning vaulted concrete abutments on concrete piles and concrete pier on a spread footing with piles. The existing structure measures 249'-0" back to back of approach bents and 43'-2" out to out of the deck.

The existing roadway shall remain open to traffic utilizing stage construction during the construction period.

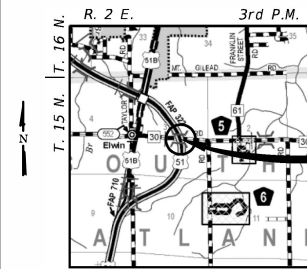

LOCATION SKETCH

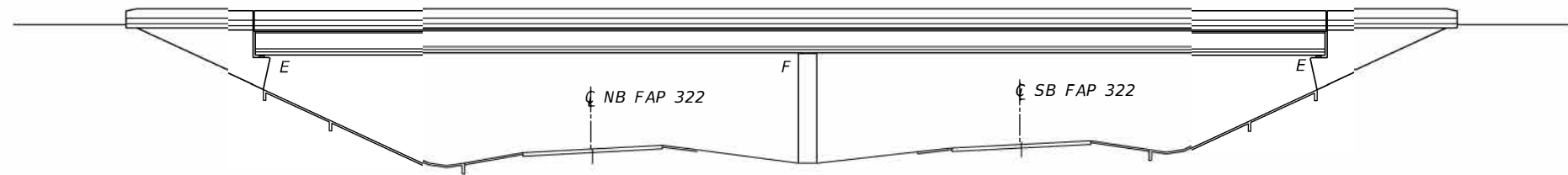

ELEVATION

**INDEX OF SHEETS**

1. General Plan and Elevation
2. General Notes and Bill of Material
3. Expansion Joint Replacement Details
4. Expansion Joint Replacement Details
5. Preformed Joint Strip Seal Details
6. Bar Splicer Assembly and Mechanical Splicer Details

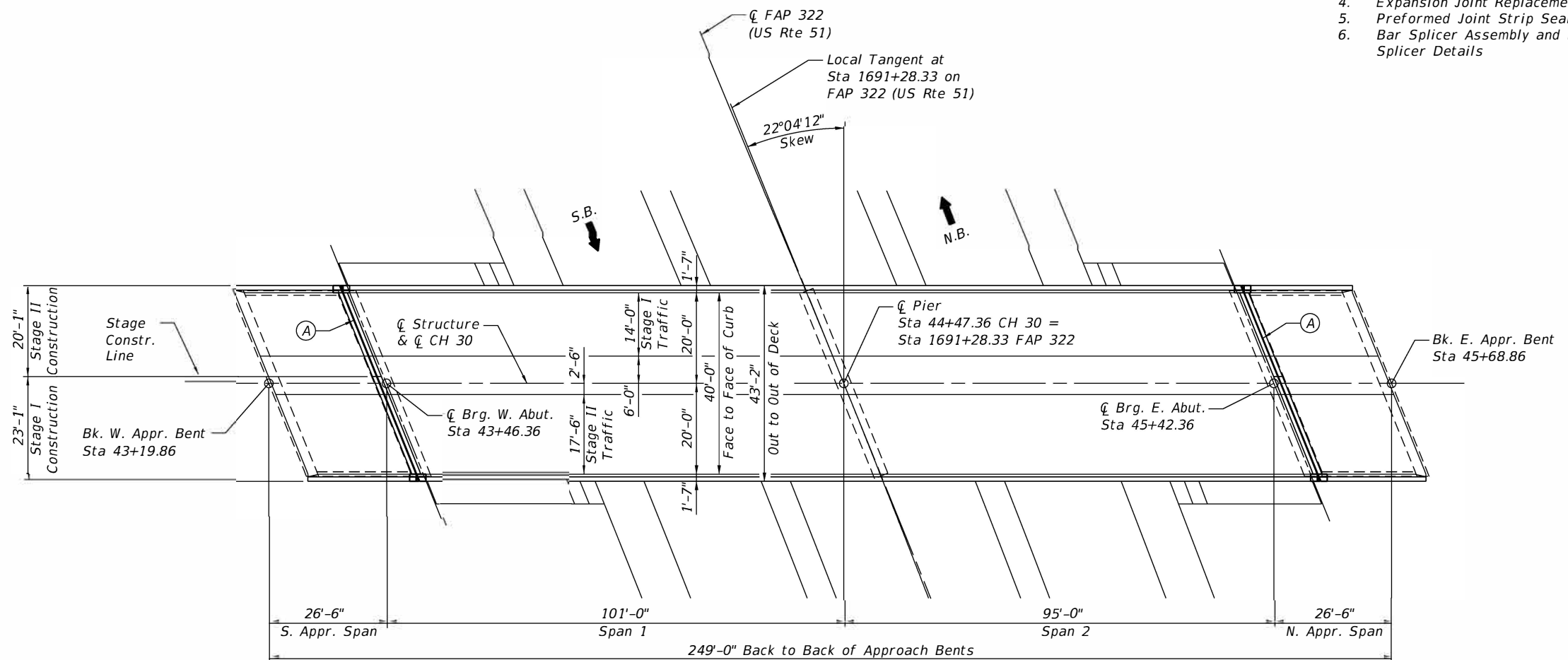

PLAN

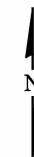
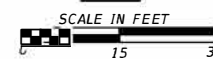

(A) Remove Existing Neoprene Expansion Joint and Install Polymer Concrete/Silicone Joint

**GENERAL PLAN & ELEVATION**  
 CH 30 OVER  
 FAP 322 (US RTE 51)  
 SECTION 58-20-1-HB2  
 MACON COUNTY  
 STATION 44+47.36  
 STRUCTURE NO. 058-0124

*Bradley G. Hummert*  
 Bradley G. Hummert  
 Licensed Structural Engineer  
 in Illinois No. 081-005428  
 Date: 1/13/20  
 Expires: November 30, 2020

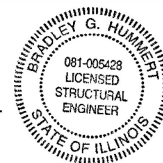

FILE NAME = H:\7322_IDOT_D7_Var\7322_07_W07_74779_US51_BridgeRepairPlans\058-0124\Merged Files\0580124_74779_01_gpel.dgn	DESIGNED -	REVISD -	F.A.P.	SECTION	COUNTY	TOTAL SHEETS	SHEET NO.
HMG ENGINEERS, INC. 9360 HOLY CROSS LANE BREESE, ILLINOIS 62230 (618) 526-9611	USER NAME = kla_ux	REVISD -	322	(46,47)RS-3 (58-20-1)RS-1	MACON	84	69
PLOT SCALE = 30.0000 / in.	DRAWN -	REVISD -	CONTRACT NO. 74779				
PLOT DATE = 1/28/2020	CHECKED -	REVISD -	ILLINOIS FED. AID PROJECT				
STATE OF ILLINOIS DEPARTMENT OF TRANSPORTATION			GENERAL PLAN AND ELEVATION				
SCALE:			SHEET 1 OF 6 SHEETS STA. TO STA.				

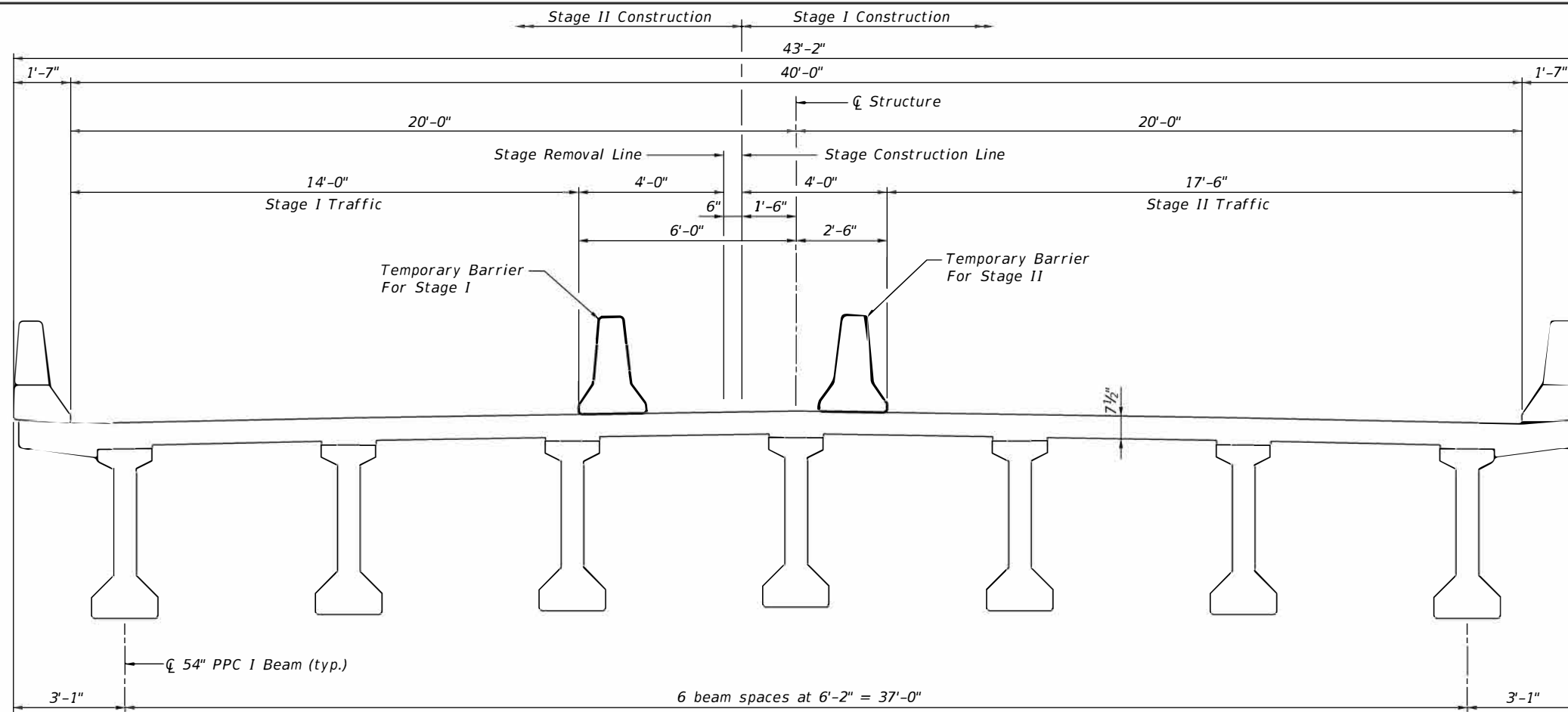

**CROSS SECTION**  
(Looking East)

**GENERAL NOTES**

Plan dimensions and details relative to existing plans are subject to nominal construction variations. The Contractor shall field verify existing dimensions and details affecting new construction and make necessary approved adjustments prior to construction or ordering of materials. Such variations shall not be cause for additional compensation for a change in scope of the work, however, the Contractor will be paid for the quantity actually furnished at the unit price bid for the work.

Reinforcement bars designated (E) shall be epoxy coated.

Prior to pouring the new concrete deck, all heavy or loose rust, loose mill scale, and other loose or potentially detrimental foreign material shall be removed from the surfaces in contact with concrete. Tightly adhered paint may remain unless otherwise noted. Removal shall be accomplished by methods that will not damage the steel and the cost will be included in the pay item covering removal of the existing concrete.

Existing reinforcement bars extending into the removal area shall be cleaned, straightened and incorporated into the new construction. Any reinforcement bars that are damaged during concrete removal shall be replaced with an approved bar splicer or anchorage system. Cost included with Concrete Removal.

Joint openings shall be adjusted according to Article 520.04 of the Standard Specifications when the deck is poured at an ambient temperature other than 50° F.

**TOTAL BILL OF MATERIAL**

ITEM	UNIT	QUANTITY
Concrete Removal	Cu Yd	5.2
Concrete Superstructure	Cu Yd	5.2
Reinforcement Bars, Epoxy Coated	Pound	1,380
Preformed Joint Strip Seal	Foot	93
Bar Splicers	Each	16

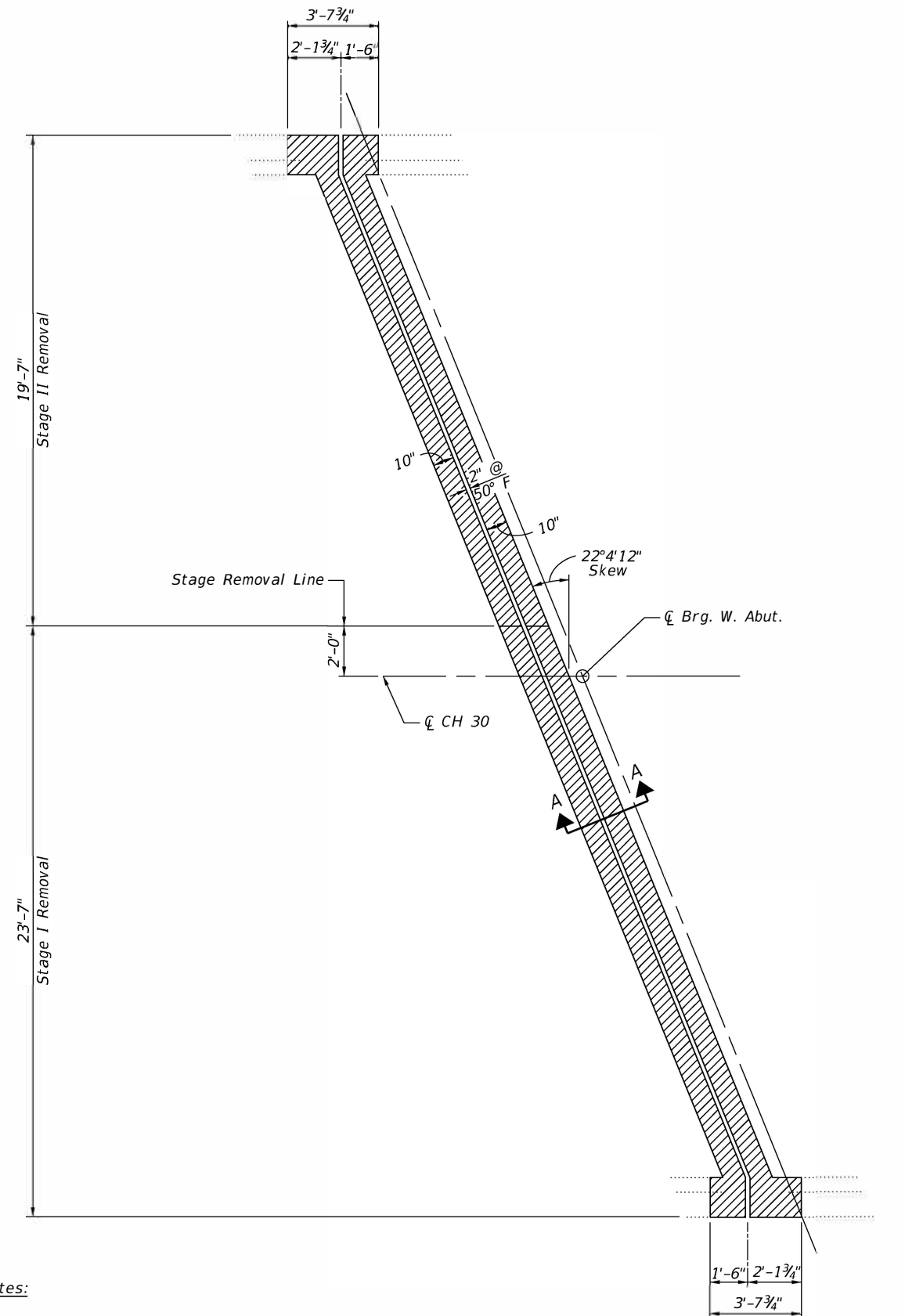

Notes:  
 Hatching indicates concrete removal.  
 See sheet 4 of 6 for Sections A-A and B-B.

**CONCRETE REMOVAL PLAN  
 WEST ABUTMENT**  
 East Abutment Similar, but Opposite

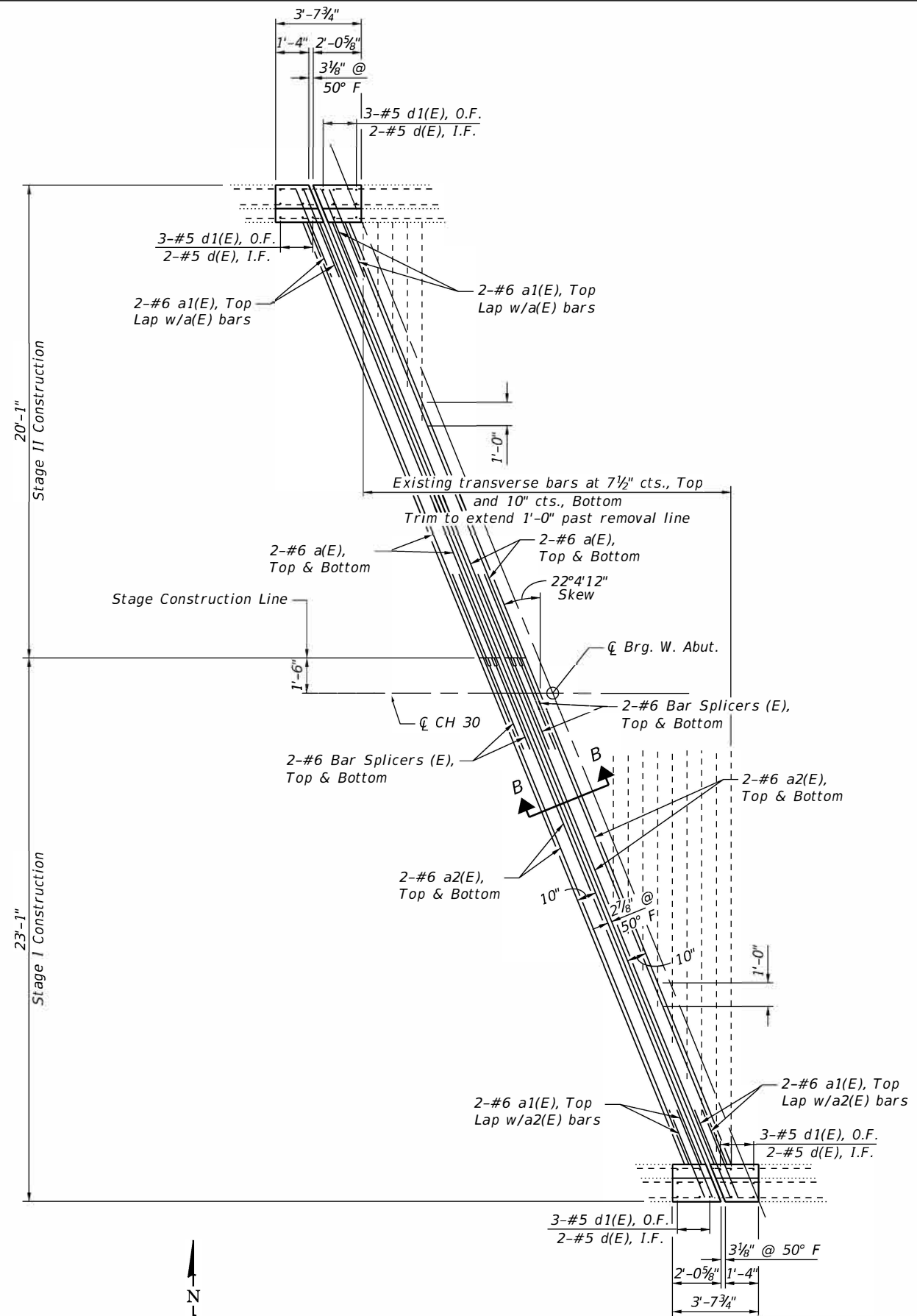

**CONCRETE REPLACEMENT PLAN  
 WEST ABUTMENT**  
 East Abutment Similar, but Opposite

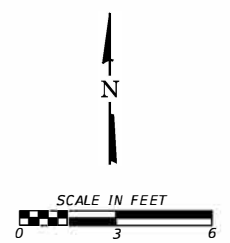

FILE NAME = H:\7322_IDOT_D7_Var\7322_07_W07_74779_US51_BridgeRepairPlans\058-0124\Merged Files\0580124_74779_03_EJ_plan.dgn	REVISD -
USER NAME = klaux	REVI SED -
DESIGNED -	REVI SED -
PLOT SCALE = 6.0000 ' / in.	REVI SED -
DRAWN -	REVI SED -
CHECKED -	REVI SED -
PLOT DATE = 1/28/2020	

**STATE OF ILLINOIS  
 DEPARTMENT OF TRANSPORTATION**

**EXPANSION JOINT REPLACEMENT DETAILS  
 STRUCTURE NO. 058-0124**

F.A.P.	SECTION	COUNTY	TOTAL SHEETS	SHEET NO.
322	(46.47)RS-3 (58-20-1)RS-1	MACON	84	71
ILLINOIS FED. AID PROJECT			CONTRACT NO. 74779	

SCALE: SHEET 3 OF 6 SHEETS STA. TO STA.

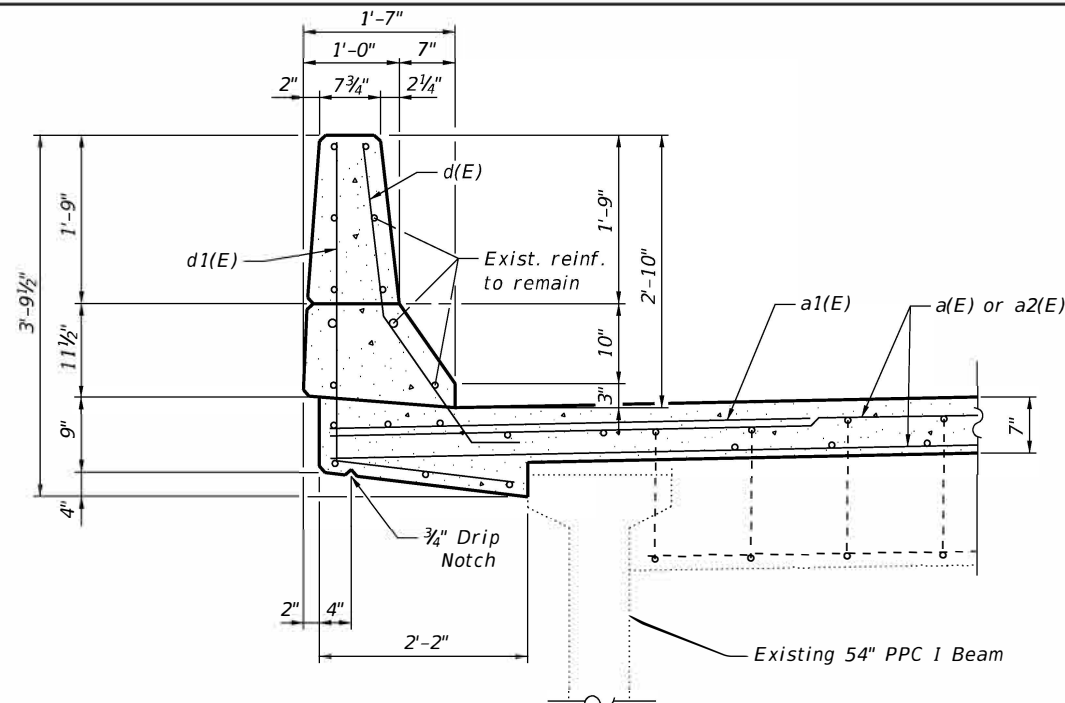

SECTION THRU PARAPET

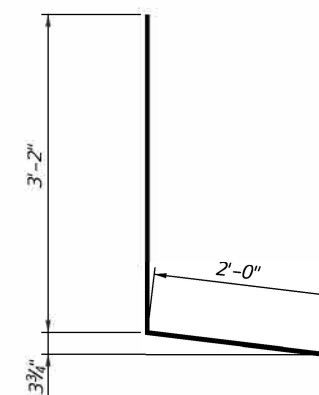

BAR d1(E)

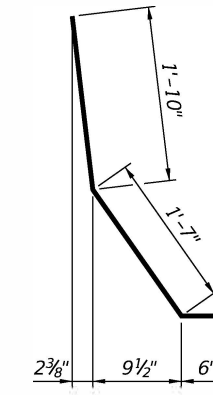

BAR d(E)

BILL OF MATERIAL

Bar	No.	Size	Length	Shape
a(E)	16	#6	21'-0"	—
a1(E)	16	#6	5'-11"	—
a2(E)	16	#6	24'-0"	—
d(E)	16	#5	3'-11"	L
d1(E)	24	#4	5'-2"	L
Concrete Removal		Cu Yd	5.2	
Concrete Superstructure		Cu Yd	5.2	
Reinforcement Bars, Epoxy Coated		Pound	1,380	
Bar Splicers		Each	16	

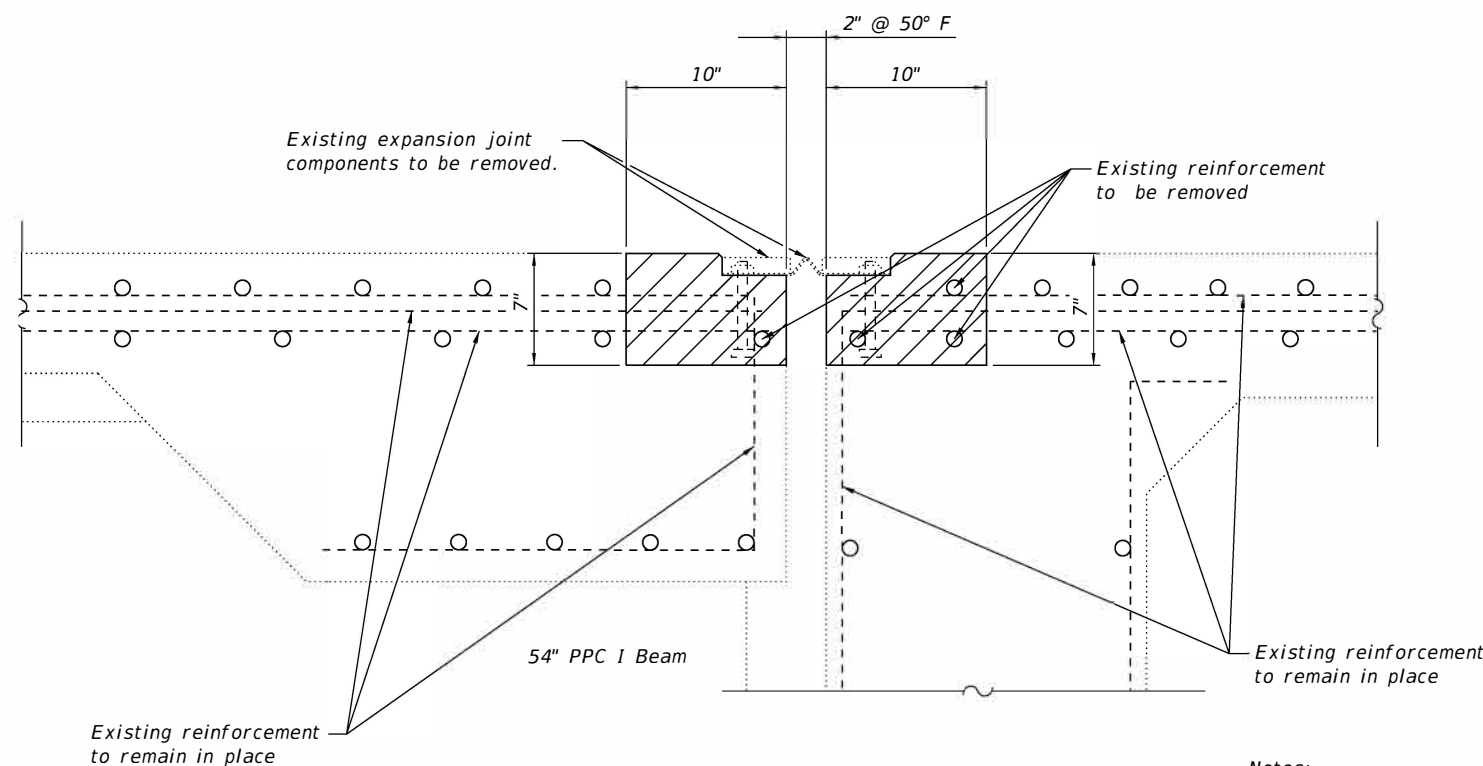

SECTION A-A

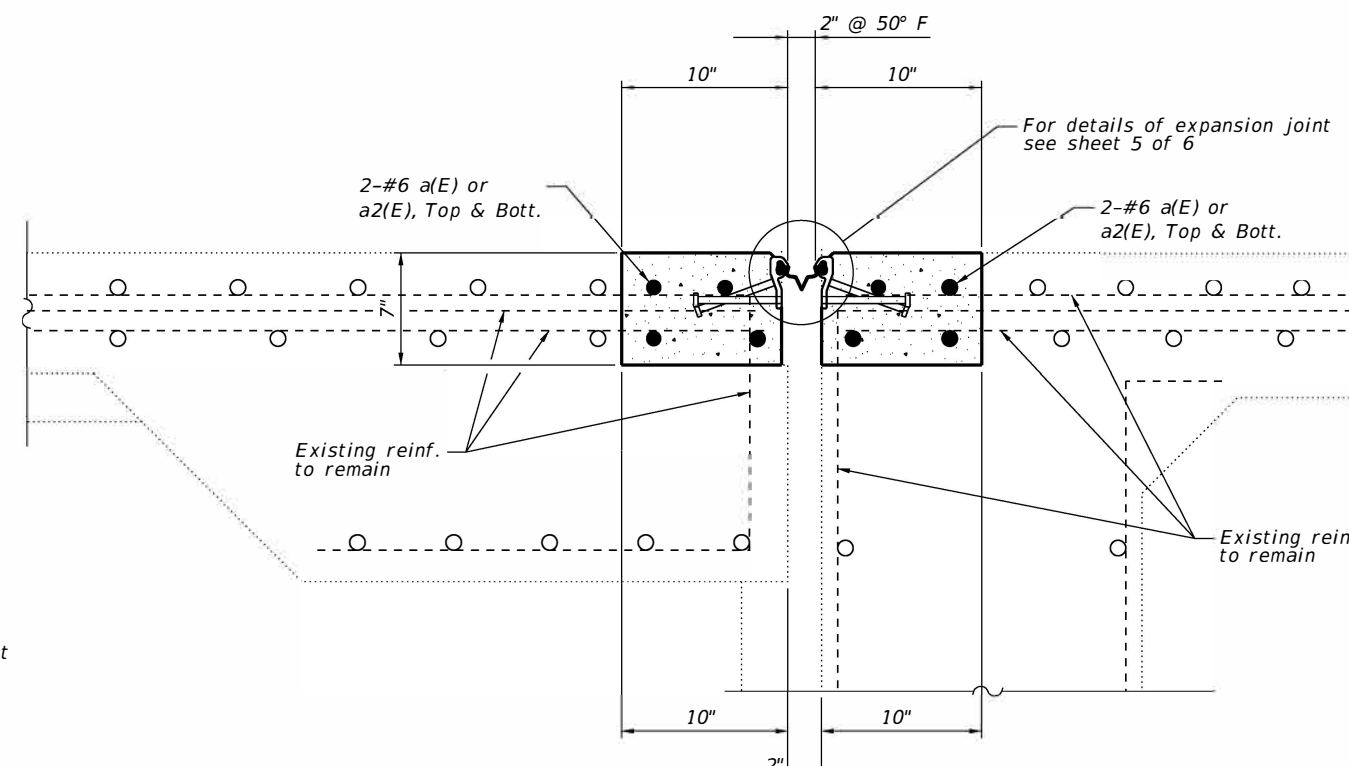

SECTION B-B

Notes:

Hatching indicates concrete removal.

Dimensions are at right angles to end of deck.

The contractor shall use extreme care during concrete removal so as not to damage the PPC I-Beam. Any beam damaged shall be repaired or replaced at the Contractor's expense.

FILE NAME = H:\7322_IDOT_D7_Var\7322_07_W07_74779_US51_BridgeRepairPlans\058-0124\Merged Files\0580124_74779_04.EJ det.dgn	REVISIONS
USER NAME = kl.aux	DESIGNED -
PLOT SCALE = 1.0000/in.	DRAWN -
PLOT DATE = 1/28/2020	CHECKED -
	REVISED -
	REVISED -
	REVISED -

STATE OF ILLINOIS  
DEPARTMENT OF TRANSPORTATION

EXPANSION JOINT REPLACEMENT DETAILS  
STRUCTURE NO. 058-0124

SCALE: SHEET 4 OF 6 SHEETS STA. TO STA.

F.A.P.	SECTION	COUNTY	TOTAL SHEETS	SHEET NO.
322	(46.47)RS-3 (58-20-1)RS-1	MACON	84	72
ILLINOIS FED. AID PROJECT			CONTRACT NO. 74779	

**HMG** ENGINEERS, INC.  
9360 HOLY CROSS LANE  
BREESE, ILLINOIS 62230  
(618) 526-9611



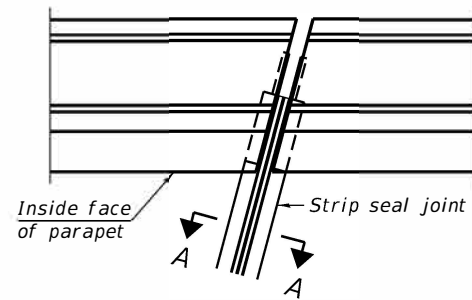

FOR SKEWS  $\leq 30^\circ$

PLAN AT PARAPET

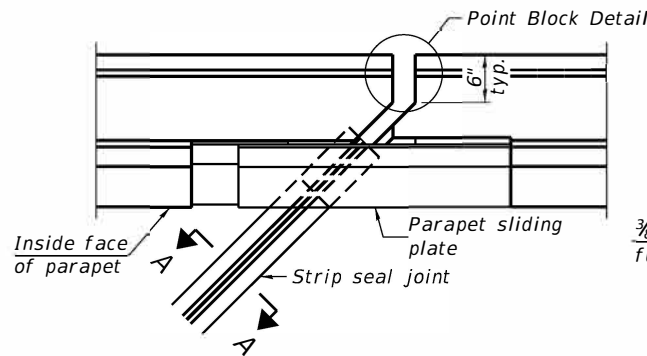

FOR SKEWS  $> 30^\circ$

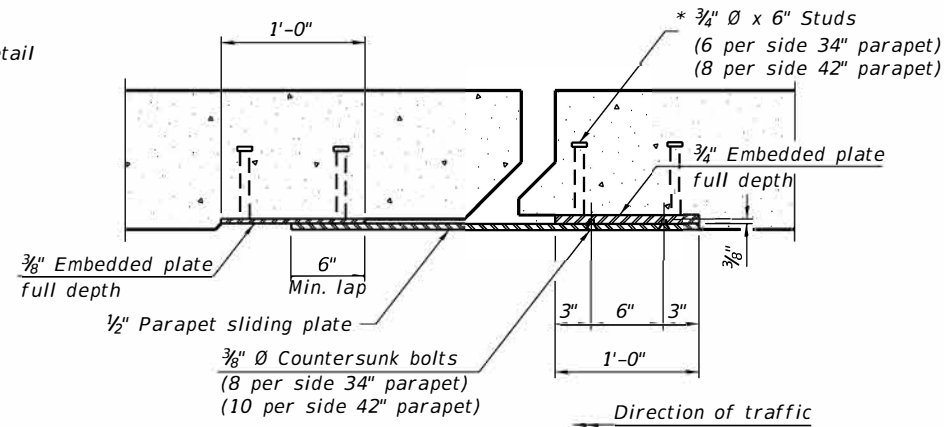

SECTION B-B

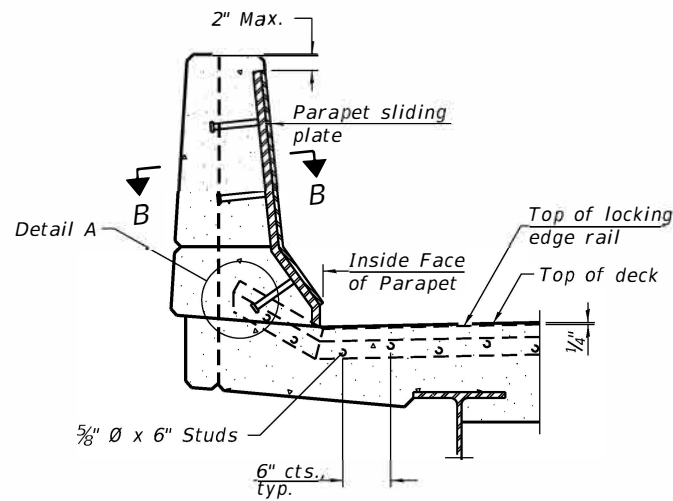

ELEVATION AT PARAPET

(Skews  $> 30^\circ$  shown. Skews  $\leq 30^\circ$  similar except as shown in plan view.)

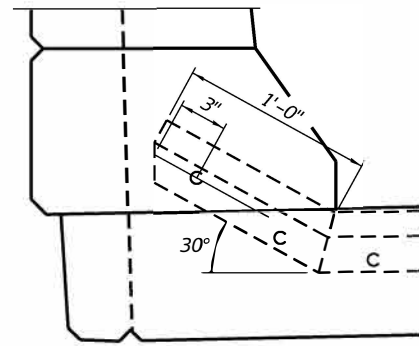

DETAIL A

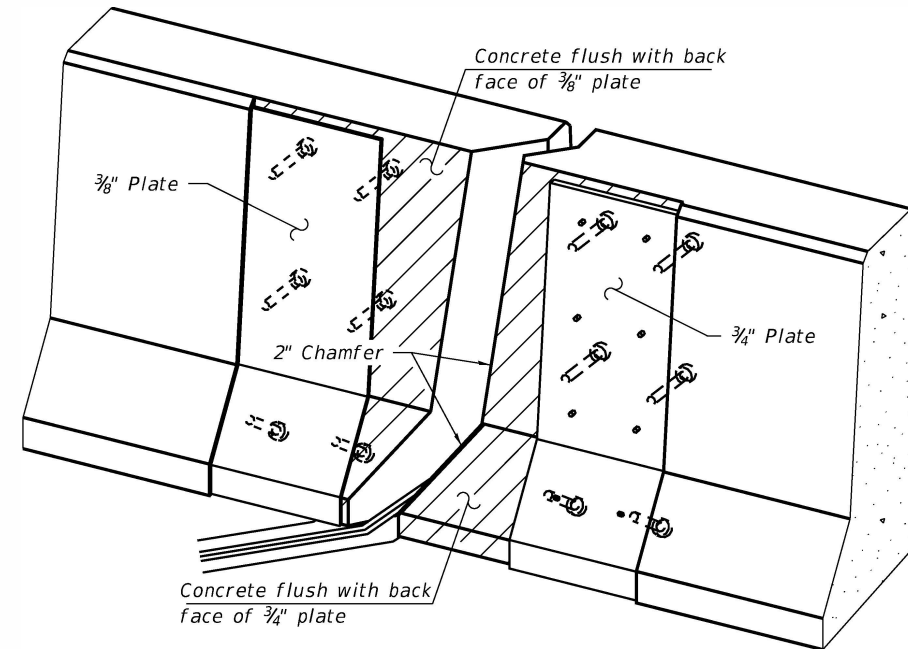

TRIMETRIC VIEW  
(Showing embedded plates only)

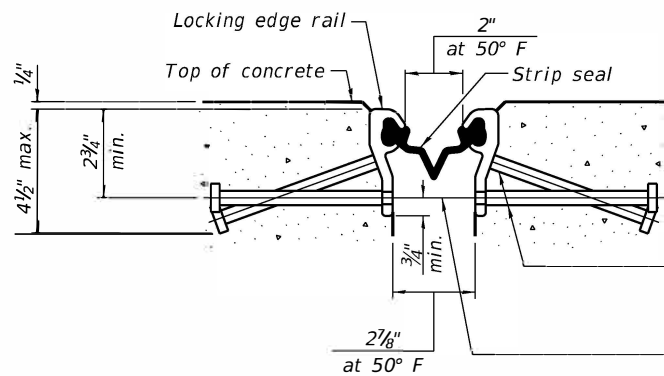

SHOWING ROLLED RAIL JOINT

\*  $5/8$ "  $\phi$  x 6" studs @ 6" cts. (alternate angled/bent studs with horizontal studs)

$3/8$ "  $\phi$  threaded rods in  $7/16$ "  $\phi$  holes at  $\pm 4$ "-0" cts. for holding the proper joint opening based on the temperature during the deck pour. Place to miss studs. All rods shall be burned, or sawed off flush with the plates after concrete is set.

SECTION A-A

\* Granular or solid flux filled headed studs conforming to Article 1006.32 of the Std. Specs., automatically end welded.

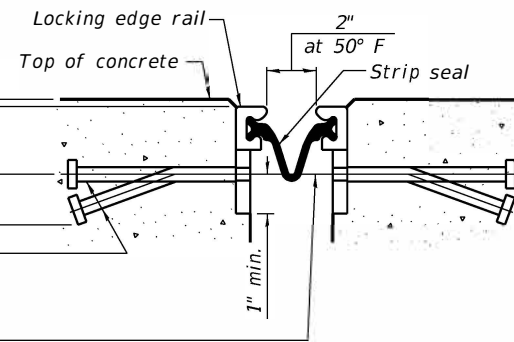

SHOWING WELDED RAIL JOINT

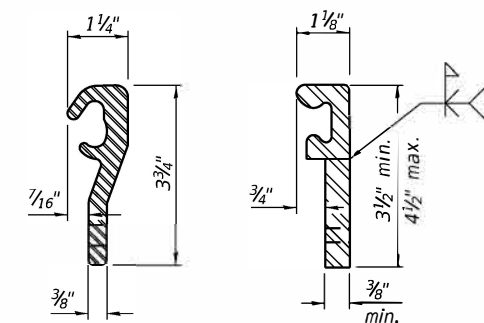

ROLLED (EXTRUDED) RAIL  
WELDED RAIL

LOCKING EDGE RAILS

\*\* Back gouge not required if complete joint penetration is verified by mock-up.

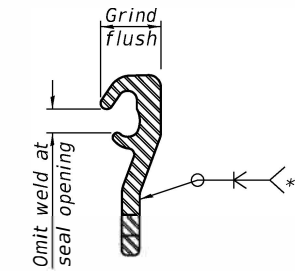

LOCKING EDGE RAIL SPLICE

The inside of the locking edge rail groove shall be free of weld residue. Rolled rail shown, welded rail similar.

BILL OF MATERIAL

Item	Unit	Total
Preformed Joint Strip Seal	Foot	93

EJ-SS

8-11-17

FILE NAME = H:\7322_IDOT_D7_Var\7322_07_W07_74779_US51_BridgeRepairPlans\058-0124\Merged Files\0580124_74779_05.expt.dgn	REVISIONS	DESIGNED -	REVISIONS
HMG ENGINEERS, INC. 9360 HOLY CROSS LANE BREESE, ILLINOIS 62230 (618) 526-9611	USER NAME = klauk	DRAWN -	REVISIONS
	PLOT SCALE = 2.00000 '1 in.	CHECKED -	REVISIONS
	PLOT DATE = 1/28/2020		

STATE OF ILLINOIS  
DEPARTMENT OF TRANSPORTATION

PREFORMED JOINT STRIP SEAL  
STRUCTURE NO. 058-0124

SCALE: SHEET 5 OF 6 SHEETS STA. TO STA.

F.A.P.	SECTION	COUNTY	TOTAL SHEETS	SHEET NO.
322	(46,47)RS-3 (58-20-1)RS-1	MACON	84	73
ILLINOIS FED. AID PROJECT			CONTRACT NO. 74779	

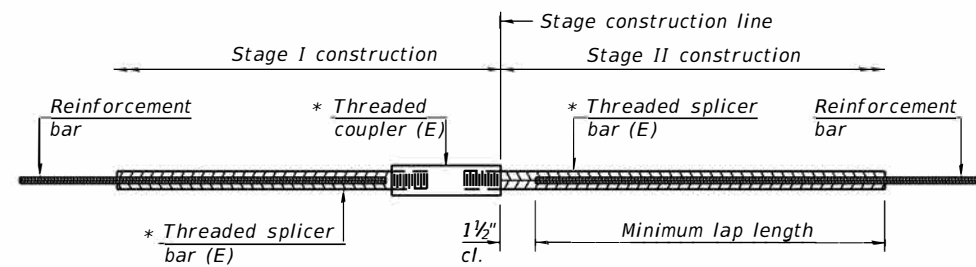

**STANDARD BAR SPLICER ASSEMBLY**

Threaded splicer bar length = min. lap length + 1 1/2" + thread length

\* Epoxy not required on Bar Splicer Assembly components used in conjunction with black bars.

Location	Bar size	No. assemblies required	Minimum lap length
Expansion Joint	#6	16	3'-7"

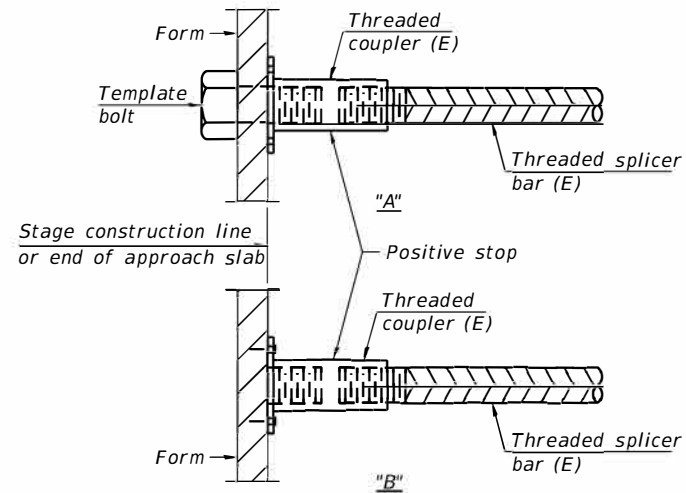

**INSTALLATION AND SETTING METHODS**

"A" : Set bar splicer assembly by means of a template bolt.

"B" : Set bar splicer assembly by nailing to wood forms or cementing to steel forms.

(E) : Indicates epoxy coating.

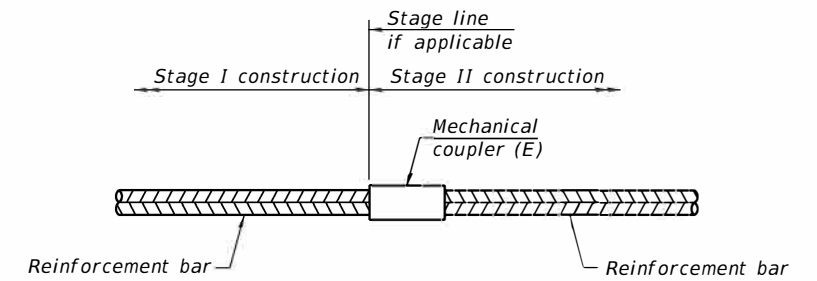

**STANDARD MECHANICAL SPLICER**

Location	Bar size	No. assemblies required

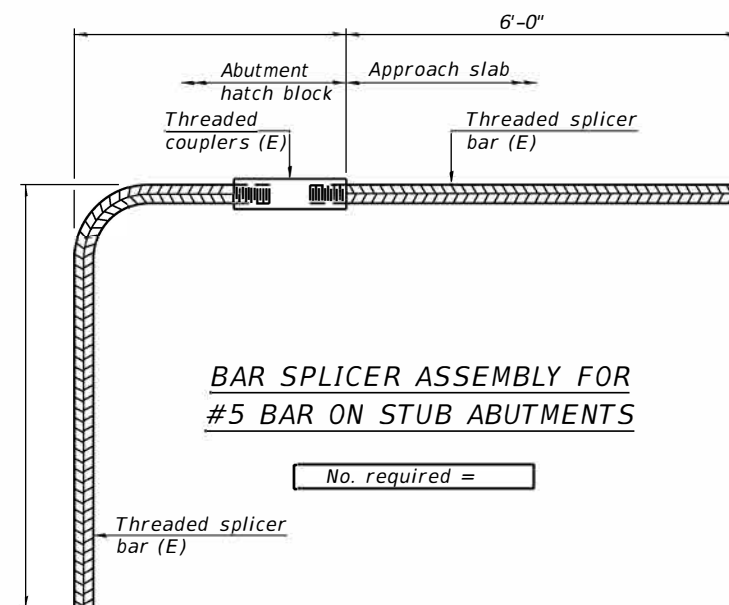

**BAR SPLICER ASSEMBLY FOR #5 BAR ON STUB ABUTMENTS**

No. required =

**NOTES**

Splicer bars shall be deformed with threaded ends and have a minimum 60 ksi yield strength.

All reinforcement shall be lapped and tied to the splicer bars. Bar splicer assemblies shall be epoxy coated according to the requirements for reinforcement bars. See Section 508 of the Standard Specifications.

See approved list of bar splicer assemblies and mechanical splicers for alternatives.

BSD-1 2-17-2017

FILE NAME = H:\17322_IDOT_D7_Var\17322_07_W07_74779_US51_BridgeRepairPlans\058-0124\Merged Files\0580124_74779_06_splicer.dgn	DESIGNED -	REVISOR -
USER NAME = klau.x	DRAWN -	REVISIONS -
PLOT SCALE = 2.0000 ' / in.	CHECKED -	
PLOT DATE = 1/28/2020		

STATE OF ILLINOIS  
DEPARTMENT OF TRANSPORTATION

BAR SPLICER ASSEMBLY AND  
MECHANICAL SPLICER DETAILS  
STRUCTURE NO. 058-0124

SCALE: SHEET 6 OF 6 SHEETS STA. TO STA.

F.A.P.	SECTION	COUNTY	TOTAL SHEETS	SHEET NO.
322	(46.47)RS-3 (58-20-1)RS-1	MACON	84	74
ILLINOIS FED. AID PROJECT			CONTRACT NO. 74779	

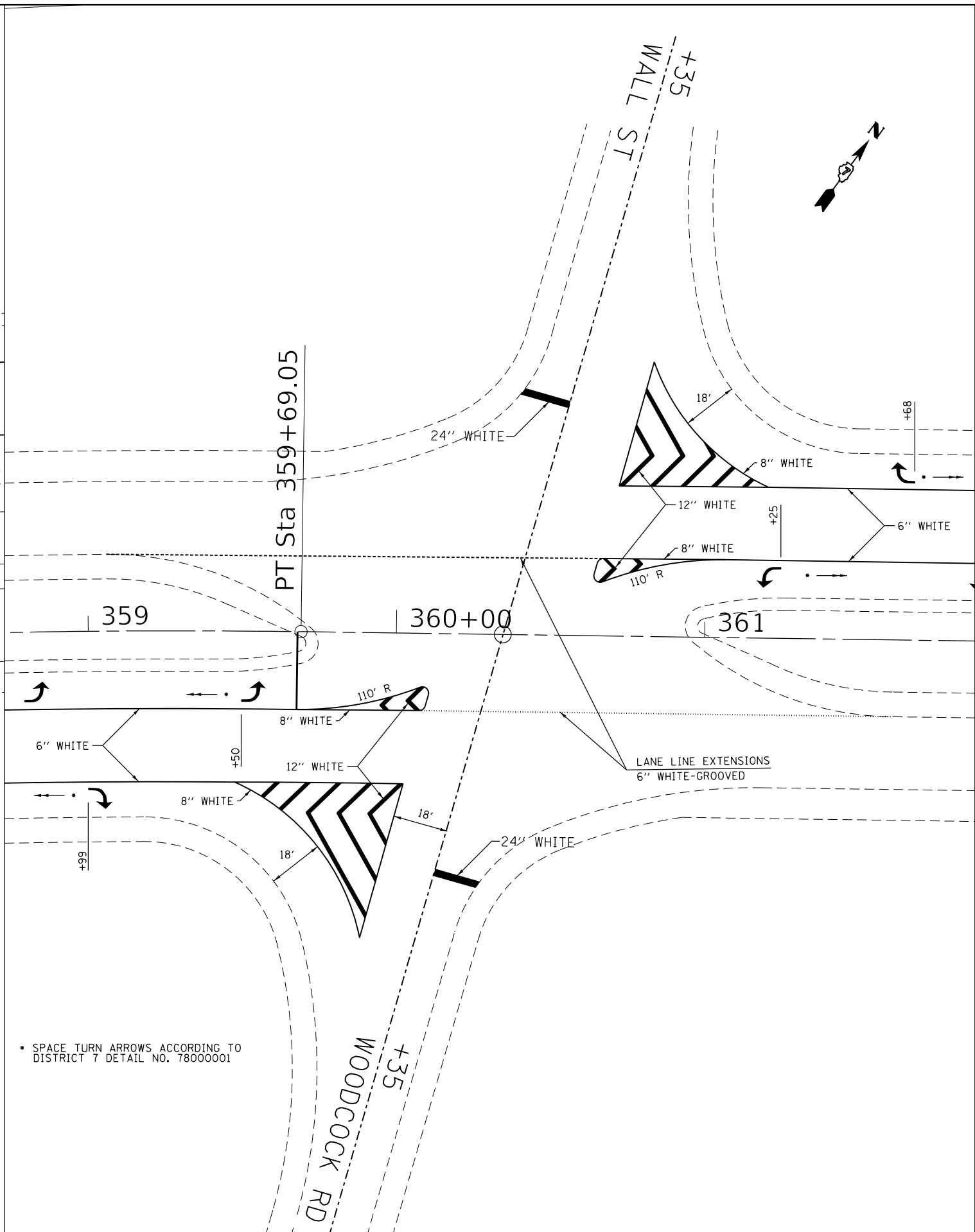
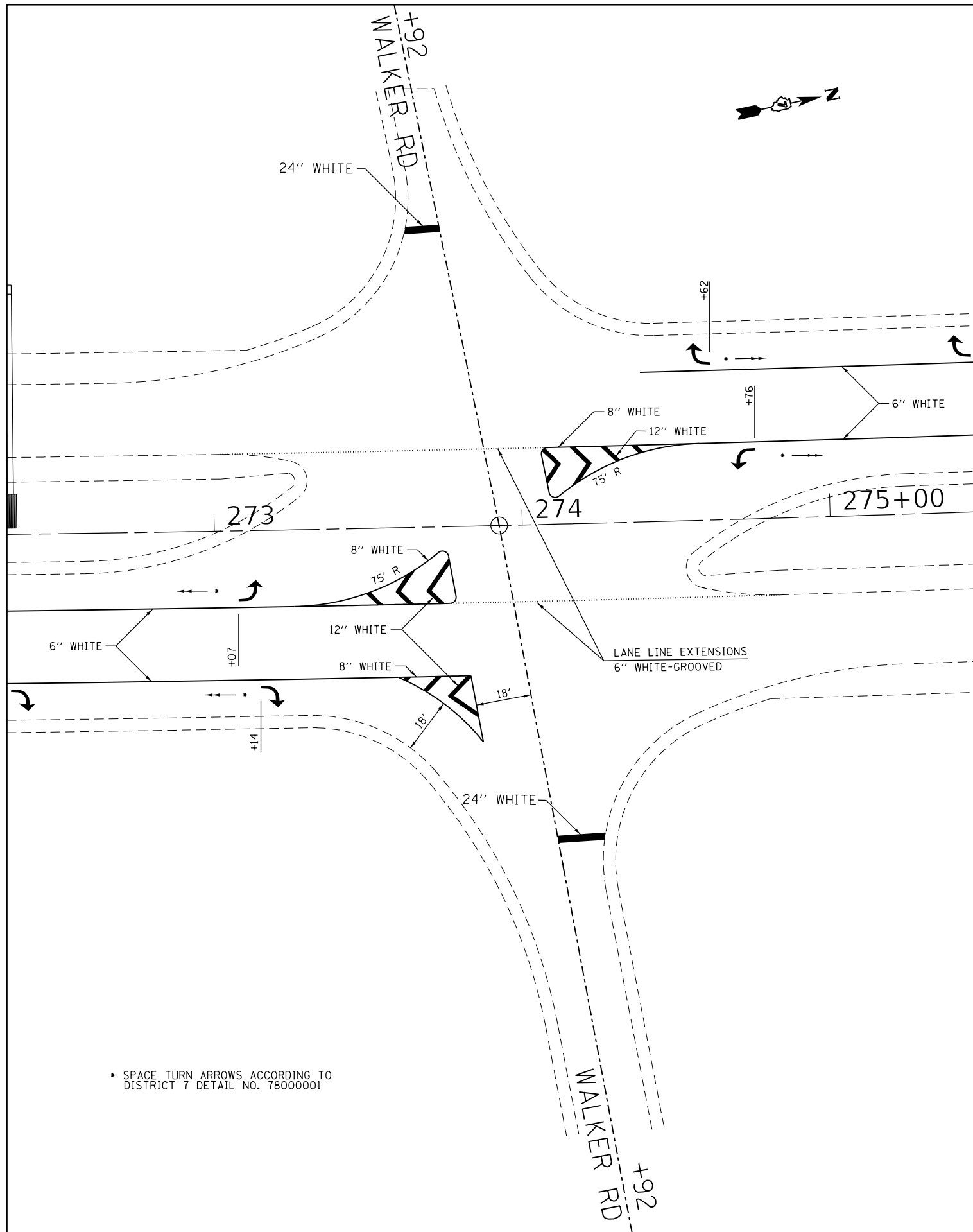

• SPACE TURN ARROWS ACCORDING TO DISTRICT 7 DETAIL NO. 78000001

• SPACE TURN ARROWS ACCORDING TO DISTRICT 7 DETAIL NO. 78000001

FILE NAME =	USER NAME = steffemk	DESIGNED -	REVISED -
pww\planroom.dot\illinois.gov\PWIDOT\Documents\DOT Offices\District 7\Projects\74779\CADDData\CADSheets\DRAWN-shi-details.dgn		DRAWN -	REVISED -
Default	PLOT SCALE = 40.0000 ' / in.	CHECKED -	REVISED -
	PLOT DATE = 1/29/2020	DATE -	REVISED -

**STATE OF ILLINOIS  
DEPARTMENT OF TRANSPORTATION**

**STRIPING DETAILS**

SCALE: 1" = 20' SHEET 1 OF 3 SHEETS STA. TO STA.

F.A.P. RTE.	SECTION	COUNTY	TOTAL SHEETS	SHEET NO.
322A	(46,47)RS-3, (58-20-1)RS-1	MACON	84	75
CONTRACT NO. 74779				
ILLINOIS FED. AID PROJECT				

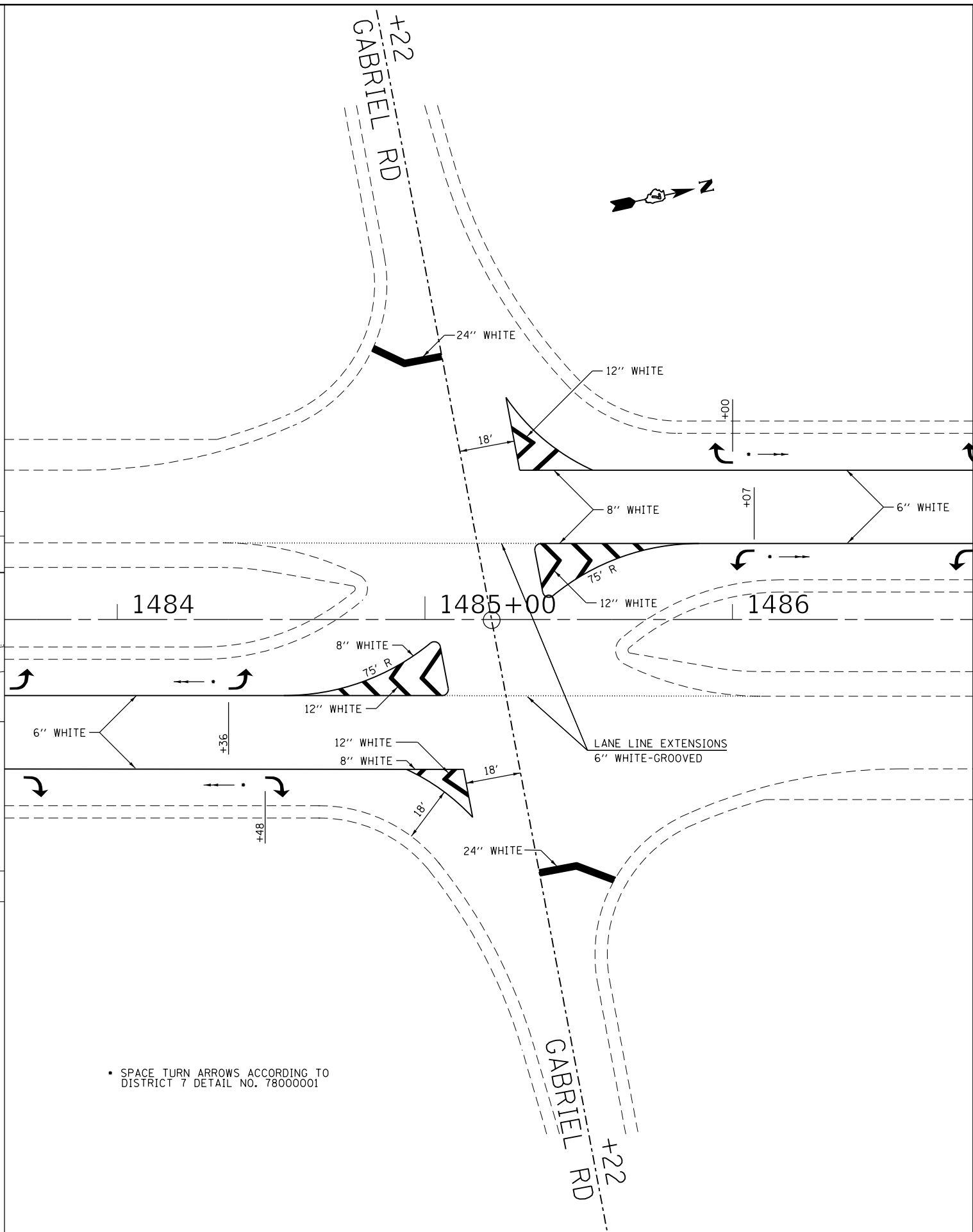
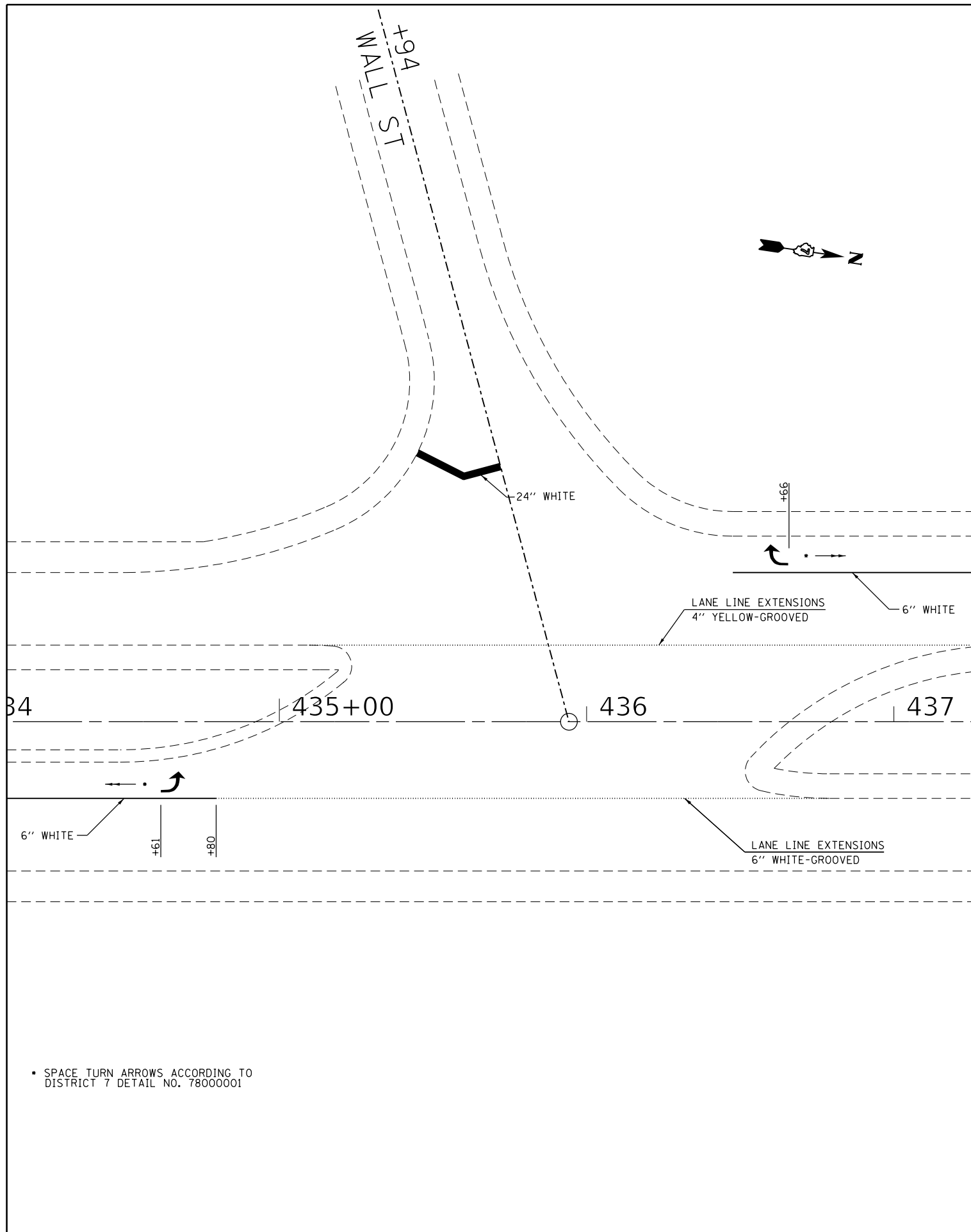

• SPACE TURN ARROWS ACCORDING TO DISTRICT 7 DETAIL NO. 78000001

• SPACE TURN ARROWS ACCORDING TO DISTRICT 7 DETAIL NO. 78000001

FILE NAME =	USER NAME = steffenmk	DESIGNED -	REVISED -
pwz\planroom\dot.illinois.gov\PWIDOT\Documents\DOT Offices\District 7\Projects\74779\CADDData\CADsheets\DRAWN-shi-details.dgn		DRAWN -	REVISED -
	PLOT SCALE = 40.0000 ' / in.	CHECKED -	REVISED -
Default	PLOT DATE = 1/29/2020	DATE -	REVISED -

**STATE OF ILLINOIS  
DEPARTMENT OF TRANSPORTATION**

**STRIPING DETAILS**

SCALE: 1" = 20'    SHEET 2 OF 3 SHEETS    STA.    TO STA.

F.A.P. RTE.	SECTION	COUNTY	TOTAL SHEETS	SHEET NO.
322A	(46,47)RS-3, (58-20-1)RS-1	MACON	84	76
CONTRACT NO. 74779			ILLINOIS FED. AID PROJECT	

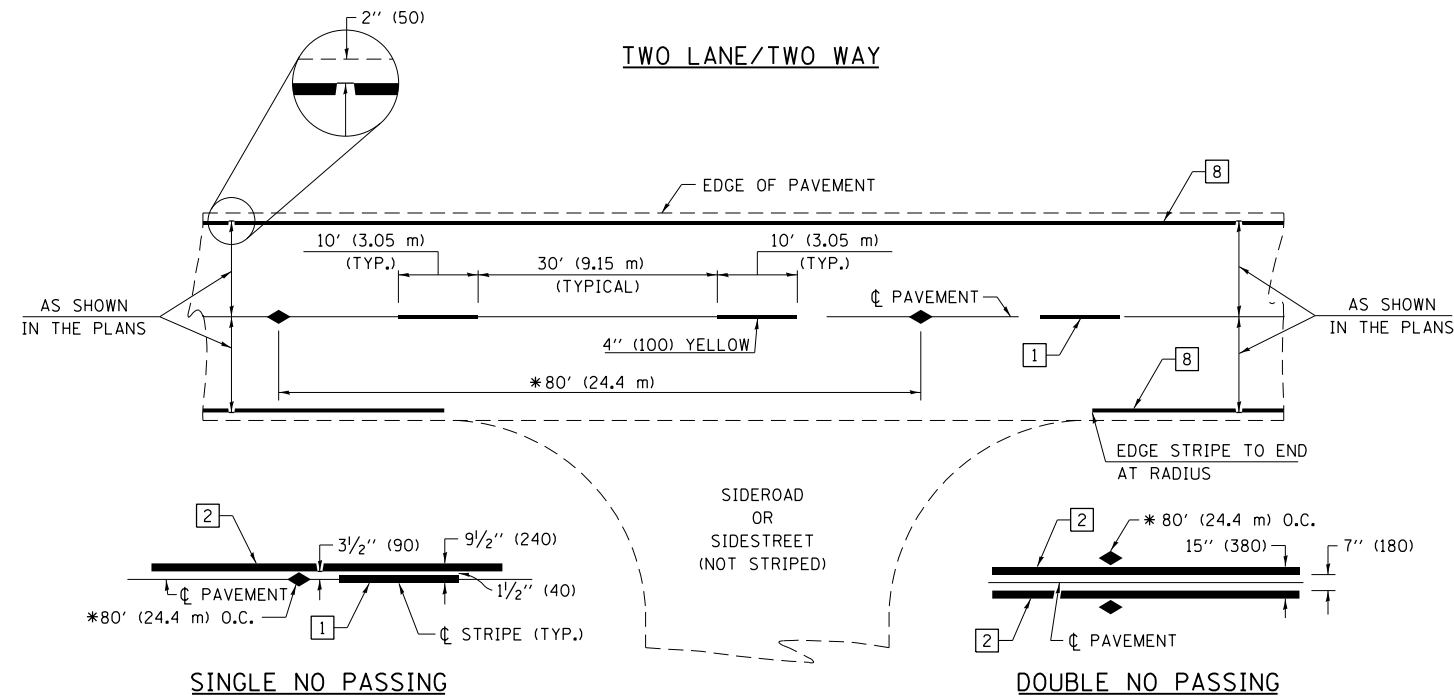

\* REDUCE TO 40' (12.2 m) O.C. ON CURVES WITH POSTED OR ADVISORY SPEEDS OF 45 mph (70 km/h) OR LESS.

**PAVEMENT MARKING LEGEND**

- 1 4" (100) SKIP-DASH (YELLOW)
  - 2 4" (100) SOLID (YELLOW)
  - 3 12" (300) DIAGONAL (YELLOW)
  - 4 4" (100) DOUBLE YELLOW (NARROW)
  - 5 12" (300) SOLID WHITE
  - 6 RESERVED
  - 7 6" (150) SKIP-DASH (WHITE)
  - 8 4" (100) SOLID (WHITE)
  - 9 12" (300) DIAGONAL (WHITE)
  - 10 6" (150) SOLID (WHITE)
  - 11 24" (600) STOP BAR (WHITE)
  - 12 8" (200) SOLID (WHITE)
  - 13 4" (100) PARKING WHITE
- 

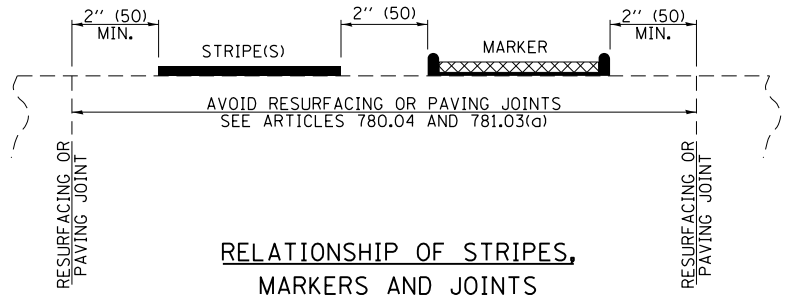

**TYPICAL PAVEMENT MARKERS LEGEND**

- ◆ TWO-WAY AMBER MARKER
- ▶ ONE-WAY AMBER MARKER
- ▷ ONE-WAY CRYSTAL MARKER

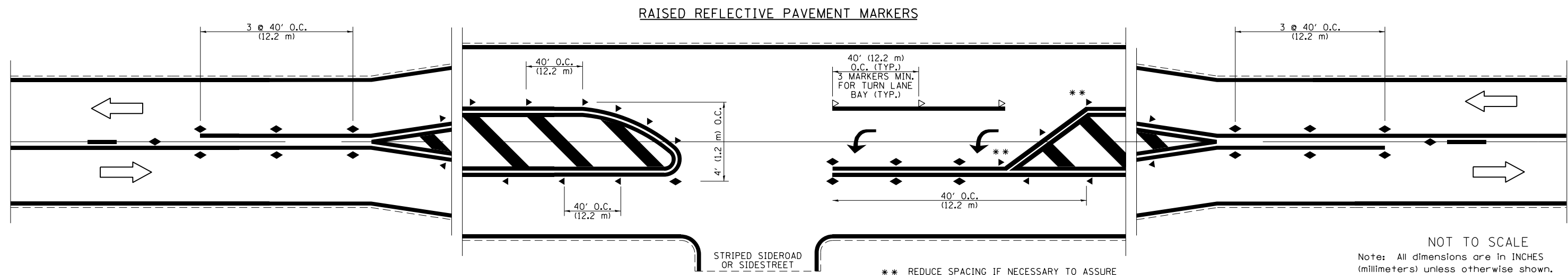

\*\* REDUCE SPACING IF NECESSARY TO ASSURE MARKERS AT CORNER POINTS.

NOT TO SCALE  
Note: All dimensions are in INCHES (millimeters) unless otherwise shown.

FILE NAME =	USER NAME = steffenmk	DESIGNED -	REVISED -	<b>STATE OF ILLINOIS DEPARTMENT OF TRANSPORTATION</b>	<b>PAVEMENT MARKING AND RAISED REFLECTIVE PAVEMENT MARKERS (RURAL &amp; URBAN APPLICATIONS)</b>	F.A.P. RTE.	SECTION	COUNTY	TOTAL SHEETS	SHEET NO.	
pw:\planroom.dot.illinois.gov\PWIDOT\Documents\IDOT Offices\District 7\Projects\74779\DRAWN\CADsheets\0774779-shd-details.dgn		REVISIONS				322A	(46,47)RS-3, (58-20-1)RS-1	MACON	84	77	
		CHECKED -	REVISIONS			CONTRACT NO. 74779					
		DATE -	REVISIONS			ILLINOIS FED. AID PROJECT					
PLOT SCALE = 1/29/2020				SCALE: N/A	SHEET NO. 1 OF 4 SHEETS	STA.	TO STA.				

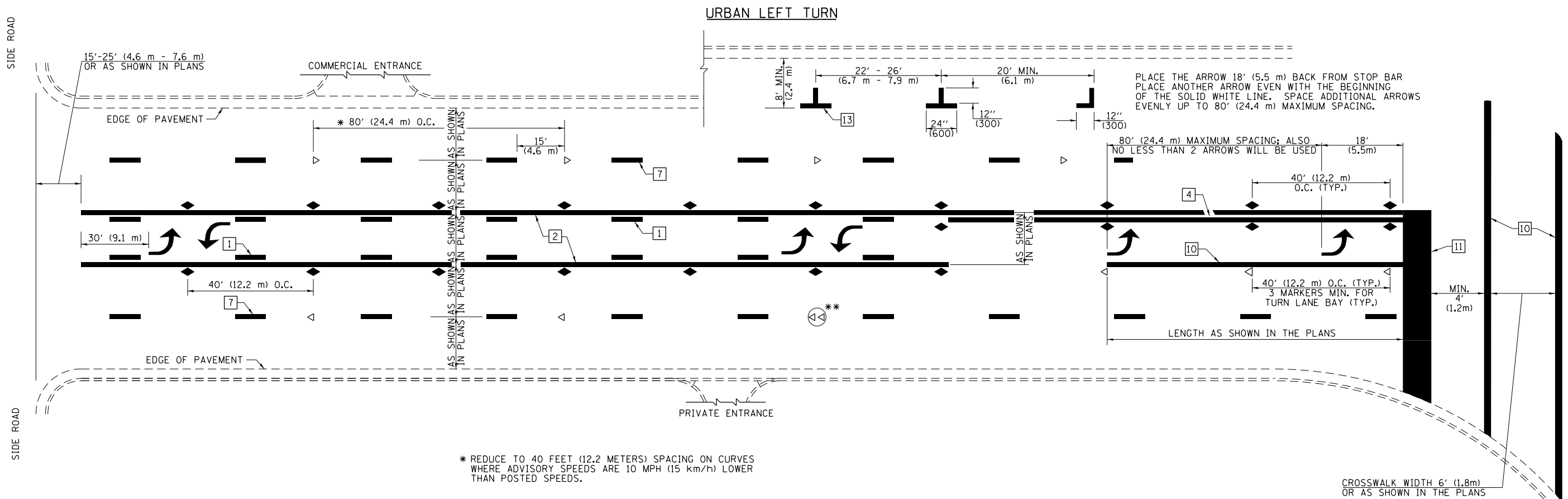

\* REDUCE TO 40 FEET (12.2 METERS) SPACING ON CURVES WHERE ADVISORY SPEEDS ARE 10 MPH (15 km/h) LOWER THAN POSTED SPEEDS.

\*\* DOUBLE LANE LINE MARKERS SHALL BE SPECIFIED AND SPACED AS SHOWN IN HIGHWAY STANDARD 781001 FOR MULTI-LANE DIVIDED AND UNDIVIDED HIGHWAYS.

**PAVEMENT MARKING LEGEND**

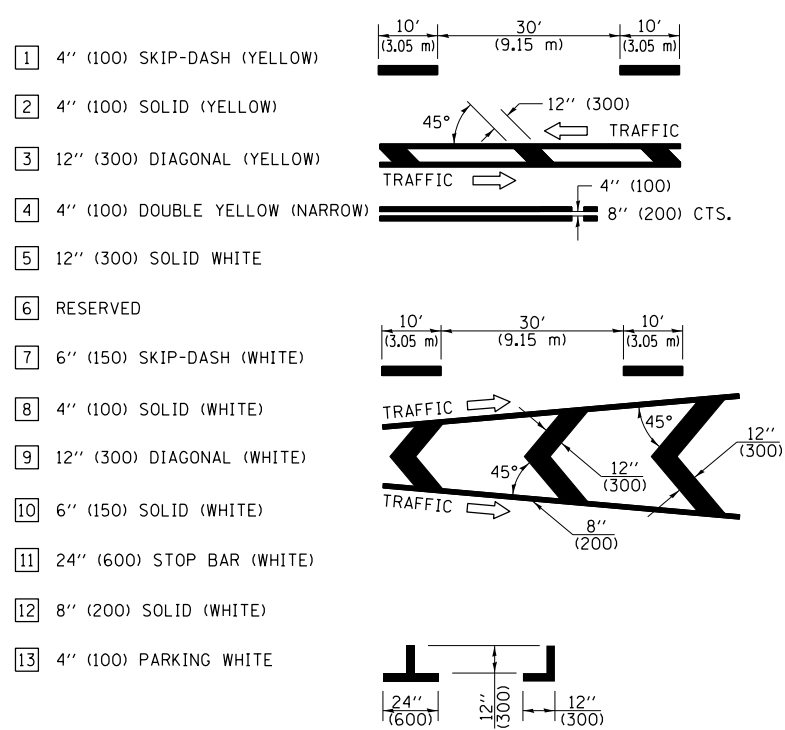

**GENERAL NOTES**

- TURN ARROW PAIRS SHALL BE PLACED AT 250' (75 m) INTERVALS AND SHALL BE EVENLY SPACED BETWEEN BOTH ENDS OF THE BIDIRECTIONAL LEFT TURN LANE. USE A MINIMUM OF TWO PAIRS PER BLOCK.
- THE SOLID YELLOW PAVEMENT MARKINGS [2] SHOULD GENERALLY START OR END NEAR THE RADIUS POINT OF EACH STREET RETURN EXCEPT WHERE ONE OR BOTH ENDS WOULD INCLUDE STOP BARS.
- THE SKIP-DASH PAVEMENT MARKINGS [1] OR [7] SHOULD BE CENTERED BETWEEN BOTH ENDS OF EACH CITY BLOCK AND SHALL BE PLACED SO THEY LINE UP ACROSS FROM EACH OTHER.
- USE LARGE ARROW SIZE FOR BOTH RURAL AND URBAN LOCATIONS. (SEE LAST PAGE OF SECTION 780x FOR SYMBOLS TABLE)
- LANE LINE EXTENSIONS SHALL BE THE SAME COLOR AND WIDTH AS THE LANE LINE BEING EXTENDED.

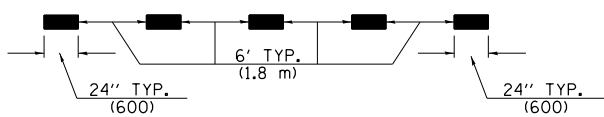

**LANE LINE EXTENSIONS**

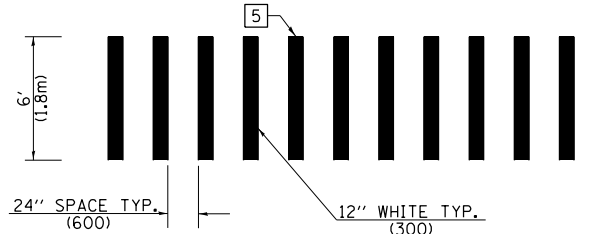

**CROSSWALK DETAIL (DECATUR CITY LIMITS ONLY)**

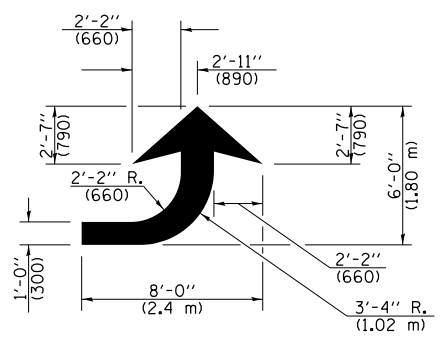

**LEFT ARROW**

REVERSE FOR RIGHT ARROW  
AREA = 15.6 SQ. FT. (1.47 m<sup>2</sup>)  
(WHITE)

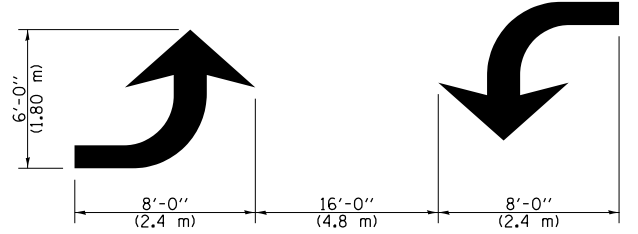

**TYPICAL DOUBLE TURN ARROWS (WHITE)**

NOT TO SCALE

Note: All dimensions are in INCHES (millimeters) unless otherwise shown.

**DISTRICT 7 DETAIL NO. 7800001**

FILE NAME =	USER NAME = steffenmk	DESIGNED -	REVISED -	<b>STATE OF ILLINOIS DEPARTMENT OF TRANSPORTATION</b>	<b>PAVEMENT MARKING AND RAISED REFLECTIVE PAVEMENT MARKERS (RURAL &amp; URBAN APPLICATIONS)</b>			F.A.P. RTE.	SECTION	COUNTY	TOTAL SHEETS	SHEET NO.
pw:\planroom.dot.illinois.gov\PIWIDOT\Documents\IDOT Offices\District 7\Projects\74779\DRAWN\CADsheets\0774779-shd-details.dwg		CHECKED -	REVISED -					322A	(46,47)RS-3, (58-20-1)RS-1	MACON	84	78
PLOT SCALE = 100.0000' / in.		DATE -	REVISED -					CONTRACT NO. 74779				
PLOT DATE = 1/29/2020								ILLINOIS FED. AID PROJECT				
					SCALE: N/A	SHEET NO. 2 OF 4 SHEETS	STA.	TO STA.				

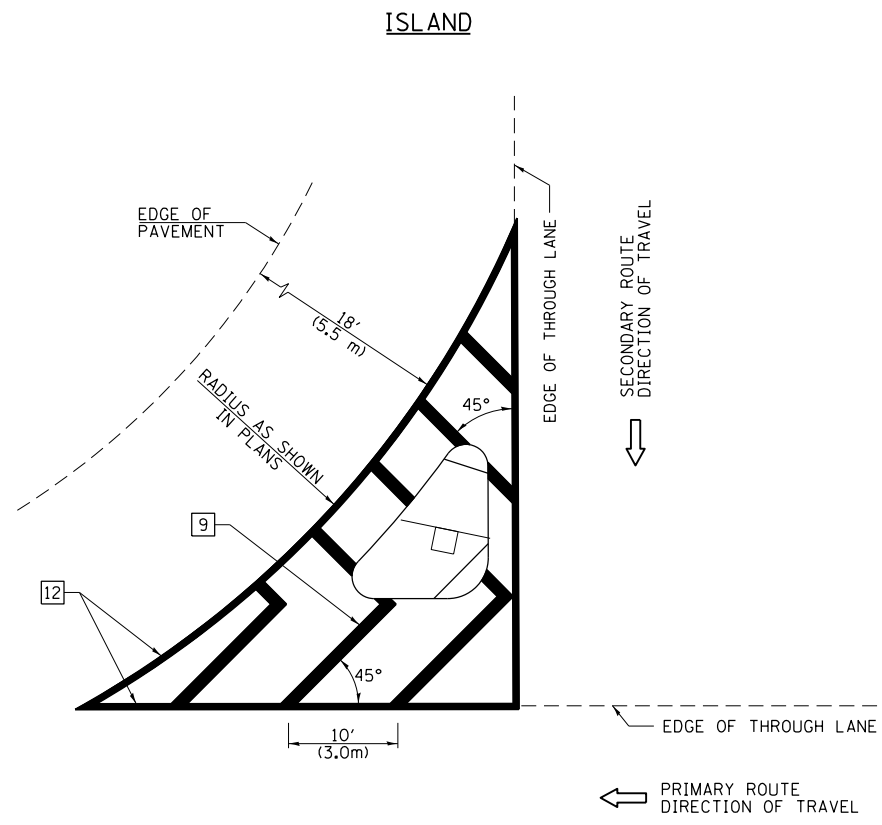

**GENERAL NOTES**

1. RAISED AND CORRUGATED MEDIANS SHALL BE OUTLINED WITH [2] IF PRESENT.
2. SOME OF THE INFORMATION INCLUDED WITH THIS DETAIL MAY NOT BE APPLICABLE TO THIS IMPROVEMENT.
3. PAVEMENT MARKINGS ARE TO BE EXTENDED THROUGH OMISSIONS WHEN APPLICABLE.
4. FINAL PAVEMENT MARKINGS SHALL BE IN PLACE PRIOR TO PLACING ANY RAISED REFLECTIVE PAVEMENT MARKERS.
5. THE FOLLOWING CRITERIA SHALL BE USED FOR SELECTING THE DIAGONAL PAVEMENT MARKING SPACING:
 

< 30 MPH (< 50 km/h)	15' (4.5 m)
30-45 MPH (50-75 km/h)	20' (6.0 m)
> 45 MPH (> 75 km/h)	30' (9.0 m)

**PAVEMENT MARKING LEGEND**

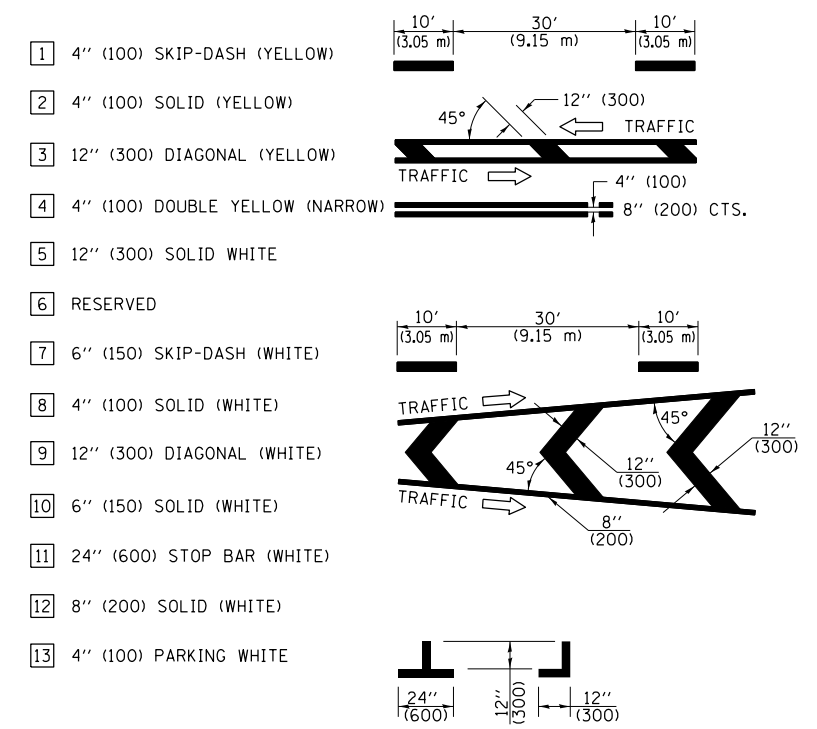

**RURAL LEFT TURN STRIPING**

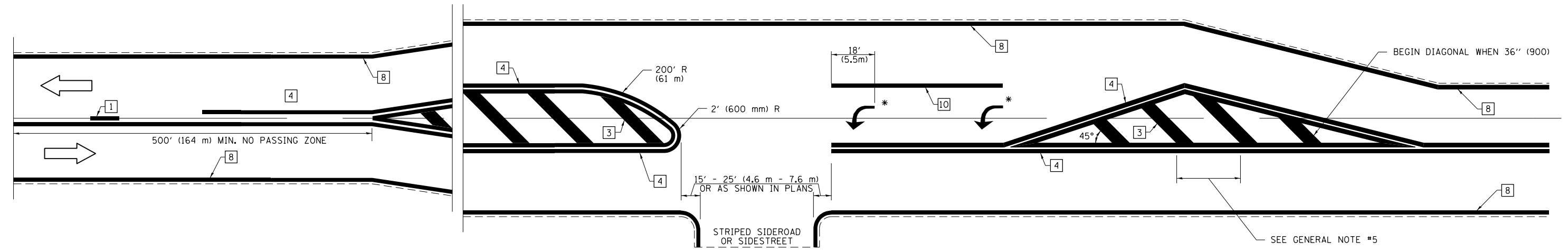

\* PLACE AN ARROW 18' (5.5 m) BACK FROM STOP BAR. PLACE ANOTHER ARROW EVEN WITH THE BEGINNING OF THE SOLID WHITE LINE. SPACE ADDITIONAL ARROWS EVENLY UP TO 80' (24.4 m) MAXIMUM SPACING. USE MINIMUM OF 2 ARROWS.

NOT TO SCALE  
 Note: All dimensions are in INCHES (millimeters) unless otherwise shown.

**DISTRICT 7 DETAIL NO. 7800001**

FILE NAME =	USER NAME = steffenmk	DESIGNED -	REVISED -	<b>STATE OF ILLINOIS DEPARTMENT OF TRANSPORTATION</b>	<b>PAVEMENT MARKING AND RAISED REFLECTIVE PAVEMENT MARKERS (RURAL &amp; URBAN APPLICATIONS)</b>	F.A.P. RTE.	SECTION	COUNTY	TOTAL SHEETS	SHEET NO.	
pw:\planroom.dot.illinois.gov\PIDOT\Documents\IDOT Offices\District 7\Projects\74779\DRAWN\CADsheets\0774779-shd-details.dgn		REVISIONS	REVISIONS			322A	(46,47)RS-3, (58-20-1)RS-1	MACON	84	79	
PLOT SCALE = 100.0000' / in.	CHECKED -	REVISIONS	REVISIONS			CONTRACT NO. 74779					
PLOT DATE = 1/29/2020	DATE -	REVISIONS	REVISIONS			ILLINOIS FED. AID PROJECT					

PAVEMENT MARKINGS AT RAILROAD-HIGHWAY GRADE CROSSING

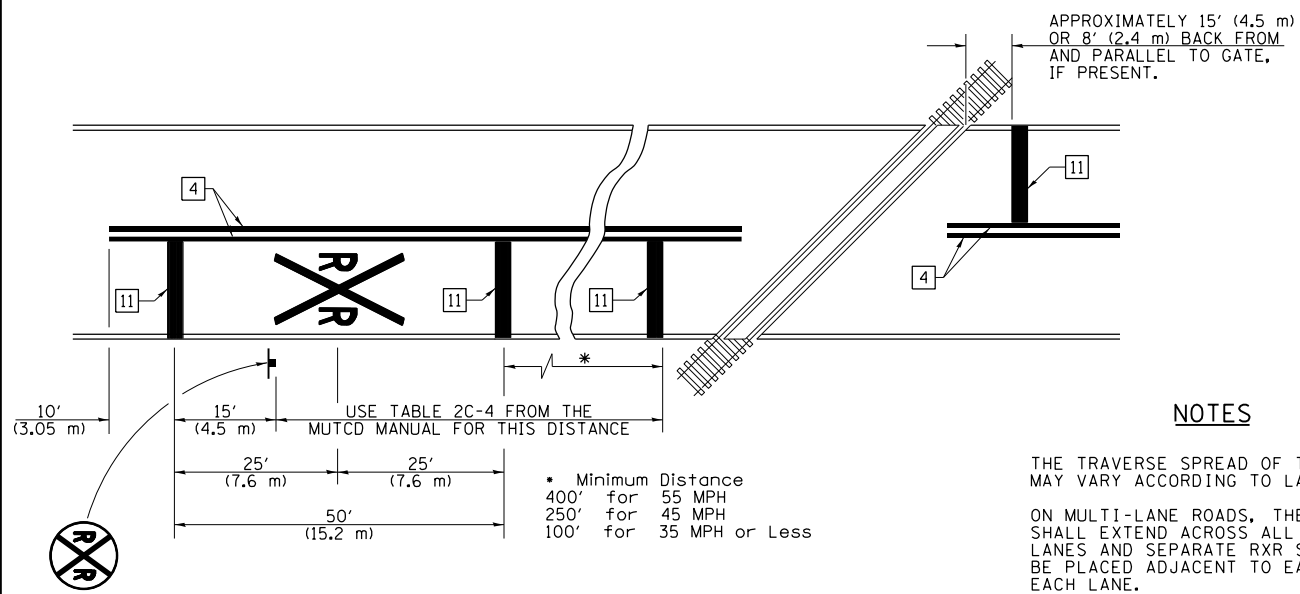

NOTES

THE TRAVERSE SPREAD OF THE "X" MAY VARY ACCORDING TO LANE WIDTH.

ON MULTI-LANE ROADS, THE STOP LINES SHALL EXTEND ACROSS ALL APPROACH LANES AND SEPARATE RXR SYMBOLS SHALL BE PLACED ADJACENT TO EACH OTHER IN EACH LANE.

WHEN THE PAVEMENT MARKING SYMBOL IS USED, A PORTION OF THE SYMBOL SHOULD BE LOCATED DIRECTLY ADJACENT TO THE ADVANCE WARNING SIGN (W10-1) AS PLACED BY TABLE II-1, CONDITION B OF THE MUTCD.

PAVEMENT MARKING LEGEND

- 1 4" (100) SKIP-DASH (YELLOW)
- 2 4" (100) SOLID (YELLOW)
- 3 12" (300) DIAGONAL (YELLOW)
- 4 4" (100) DOUBLE YELLOW (NARROW)
- 5 12" (300) SOLID WHITE
- 6 RESERVED
- 7 6" (150) SKIP-DASH (WHITE)
- 8 4" (100) SOLID (WHITE)
- 9 12" (300) DIAGONAL (WHITE)
- 10 6" (150) SOLID (WHITE)
- 11 24" (600) STOP BAR (WHITE)
- 12 8" (200) SOLID (WHITE)
- 13 4" (100) PARKING WHITE

RAILROAD CROSSING WITH INTERCONNECT ONLY

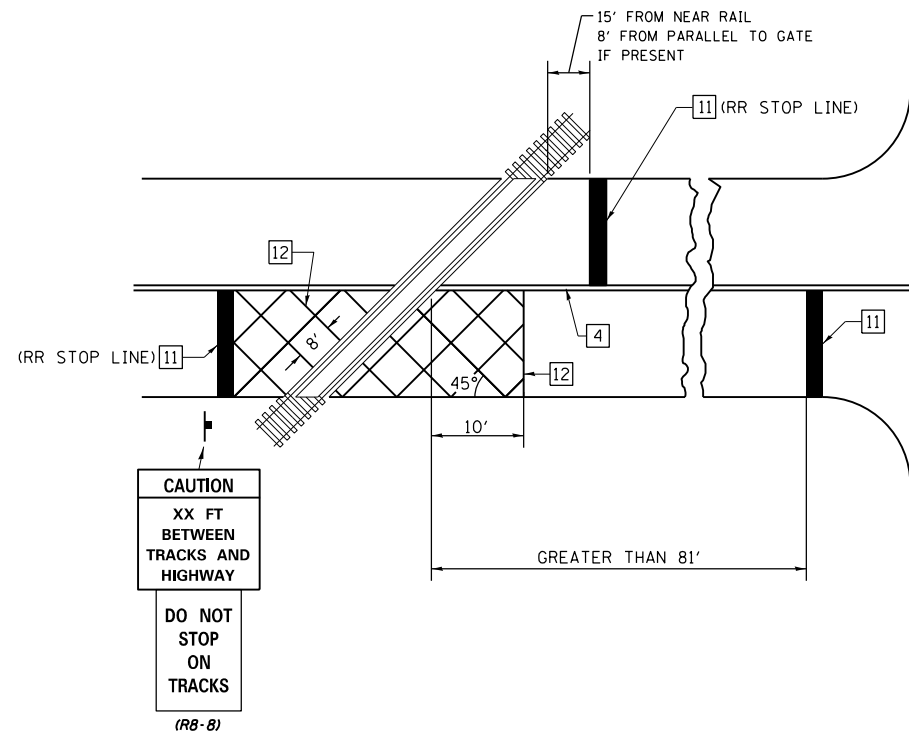

RAILROAD CROSSING WITH INTERCONNECT AND PRE-SIGNALS

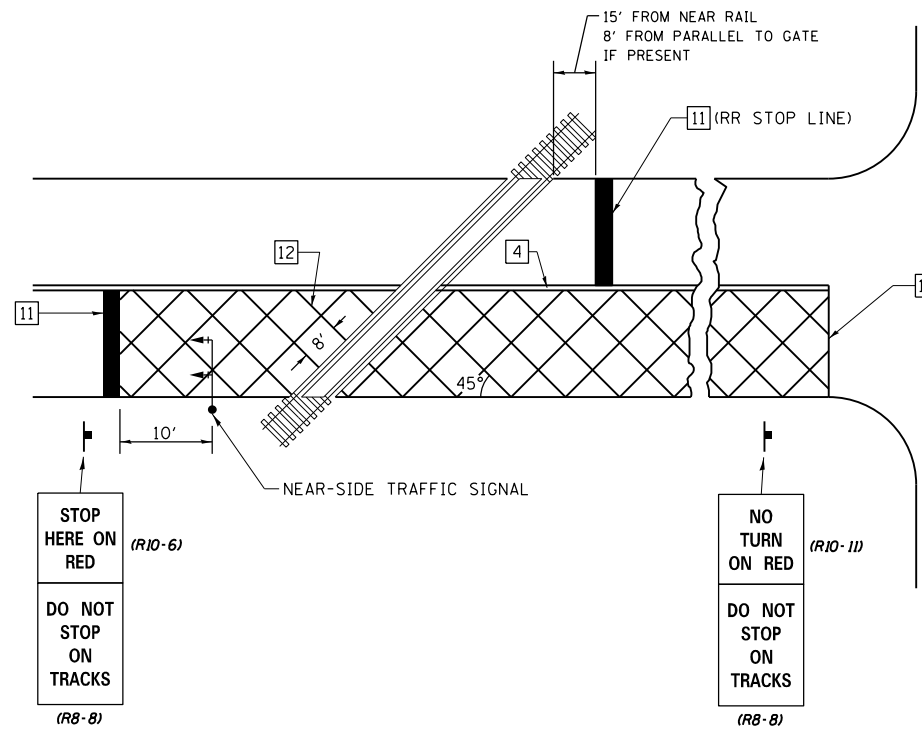

GENERAL NOTES

- SUPPLEMENTAL PAVEMENT MARKINGS TO BE INSTALLED ONLY ON APPROACHES TO INTERSECTIONS CONTROLLED BY TRAFFIC SIGNALS WHICH ARE INTERCONNECTED WITH THE RAILROAD WARNING SIGNALS.
- EXTEND PAVEMENT MARKINGS TO THE INTERSECTION ONLY WHERE NEAR-SIDE TRAFFIC SIGNALS ARE USED.

SUPPLEMENTAL PAVEMENT MARKING TREATMENT FOR RAILROAD-HIGHWAY GRADE CROSSING

NOT TO SCALE

Note: All dimensions are in INCHES (millimeters) unless otherwise shown.

DISTRICT 7 DETAIL NO. 7800001

FILE NAME =	USER NAME = steffenmk	DESIGNED -	REVISED -	<b>STATE OF ILLINOIS DEPARTMENT OF TRANSPORTATION</b>	<b>PAVEMENT MARKING AND RAISED REFLECTIVE PAVEMENT MARKERS (RURAL &amp; URBAN APPLICATIONS)</b>	F.A.P. RTE.	SECTION	COUNTY	TOTAL SHEETS	SHEET NO.	
pw:\planroom.dot.illinois.gov\PIWIDOT\Documents\IDOT Offices\District 7\Projects\74779\DRAWN\CADsheets\0774779-sht-details.dgn		REVISIONS	REVISIONS			322A	(46,47)RS-3, (58-20-1)RS-1	MACON	84	80	
		CHECKED -	REVISIONS			CONTRACT NO. 74779					
		DATE -	REVISIONS			ILLINOIS FED. AID PROJECT					



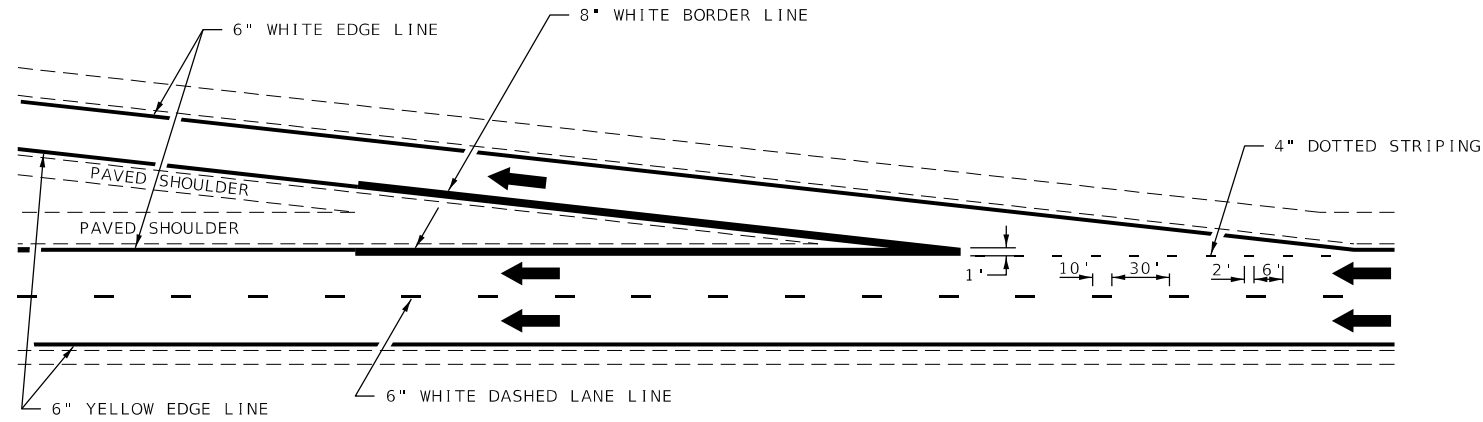

TYPICAL EXIT RAMP MARKING

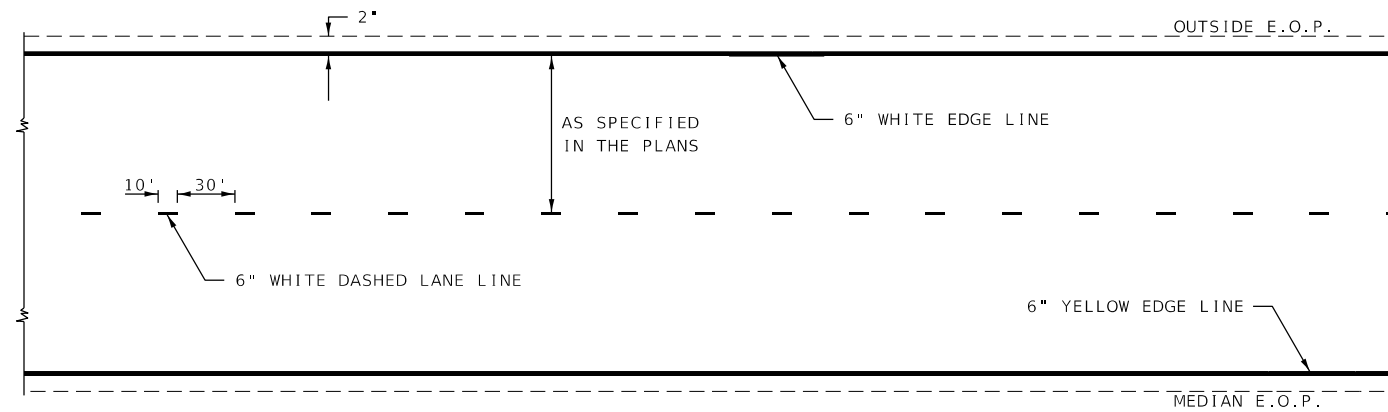

TYPICAL CENTERLING & EDGELINE MARKINGS

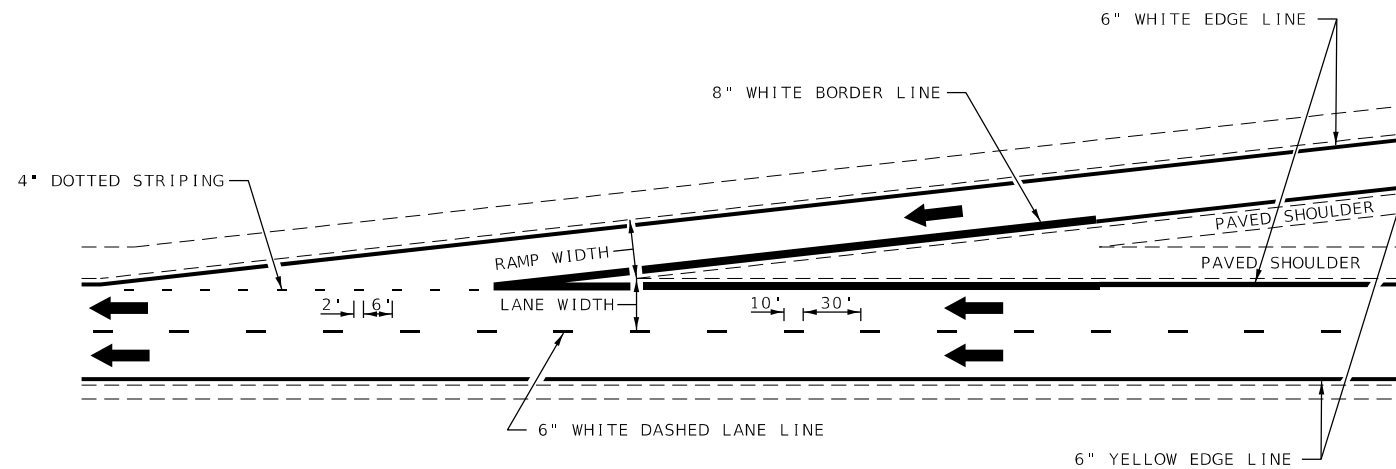

TYPICAL ENTRANCE RAMP MARKING

NOT TO SCALE

**DISTRICT 7 DETAIL NO. 7800002**

MODEL: Default  
FILE: h:\a\c\p\pub\harcourt\dot\Documents\DOT\_Offices\District\_7\Projects\74779\CA00Data\CAD\Drawings\74779-shc-detailed.dgn

USER NAME = steffenmk	DESIGNED -	REVISED - DRM 08-04
	DRAWN -	REVISED - MKS 04-08
PLOT SCALE = 100.0000' / in.	CHECKED -	REVISED - DRM 01-09
PLOT DATE = 1/29/2020	DATE -	REVISED - DRM 12-10

**STATE OF ILLINOIS  
DEPARTMENT OF TRANSPORTATION**

**TYPICAL APPLICATIONS OF FREEWAY/EXPRESSWAY  
PAVEMENT MARKING**

SCALE: SHEET 1 OF 2 SHEETS STA. TO STA.

F.A.P. RTE.	SECTION	COUNTY	TOTAL SHEETS	SHEET NO.
322A	(46,47)RS-3, (58-20-1)RS-1	MACON	84	81
CONTRACT NO. 74779				
ILLINOIS FED. AID PROJECT				



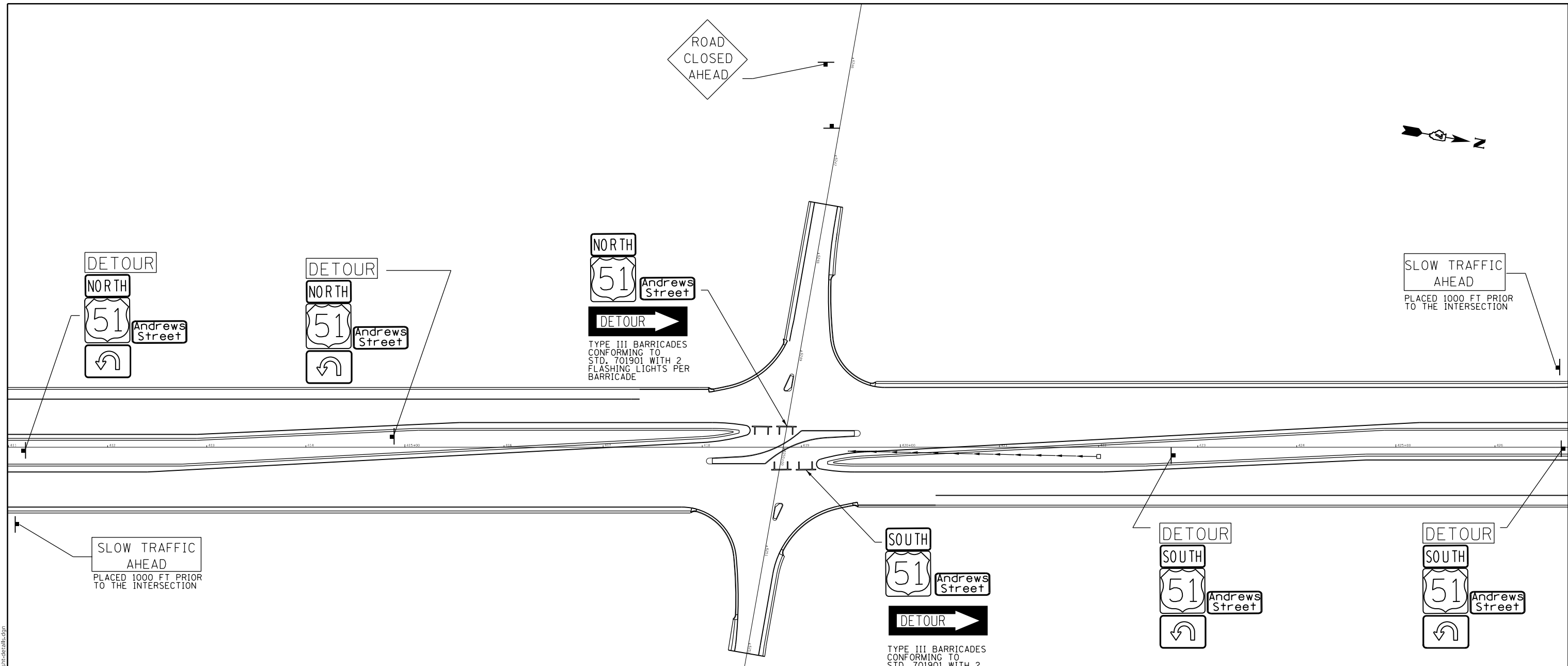

SLOW TRAFFIC AHEAD  
PLACED 1000 FT PRIOR TO THE INTERSECTION

SLOW TRAFFIC AHEAD  
PLACED 1000 FT PRIOR TO THE INTERSECTION

**SIGN LEGEND**

	M4-8-3015		W23-1-4824
	M4-10R(O)-4818		W20-3(30)-36
	M3-1-2412	<p><b>GENERAL NOTES</b>          ALL TRAFFIC CONTROL DEVICES SHALL BE FURNISHED, ERECTED AND MAINTAINED BY THE CONTRACTOR.           ALL SIGNS NOT ATTACHED TO BARRICADES SHALL BE POST MOUNTED UNLESS NOTED OTHERWISE.           LOCATIONS OF TRAFFIC CONTROL DEVICES SHALL BE DETERMINED BY THE ENGINEER.           SEE DETOUR SIGNING SPECIAL PROVISION</p>	
	M3-3-2412		
	M1-4-2424		
	24" x 18"		
	W16-8dP-4824 (O)		

MODEL: Default  
 FILE: h:\m\c\p\pub\barroom.dwg  
 PROJECT: 74779\CADD\Drawings\DOT - Offices\Drawings\74779-4824.dwg

**STATE OF ILLINOIS  
DEPARTMENT OF TRANSPORTATION**

**DETOUR SIGNING**

SCALE: SHEET OF SHEETS STA. TO STA.

F.A.P. RTE.	SECTION	COUNTY	TOTAL SHEETS	SHEET NO.
322A	(46,47)RS-3, (58-20-1)RS-1	MACON	84	83
CONTRACT NO. 74779				
ILLINOIS FED. AID PROJECT				

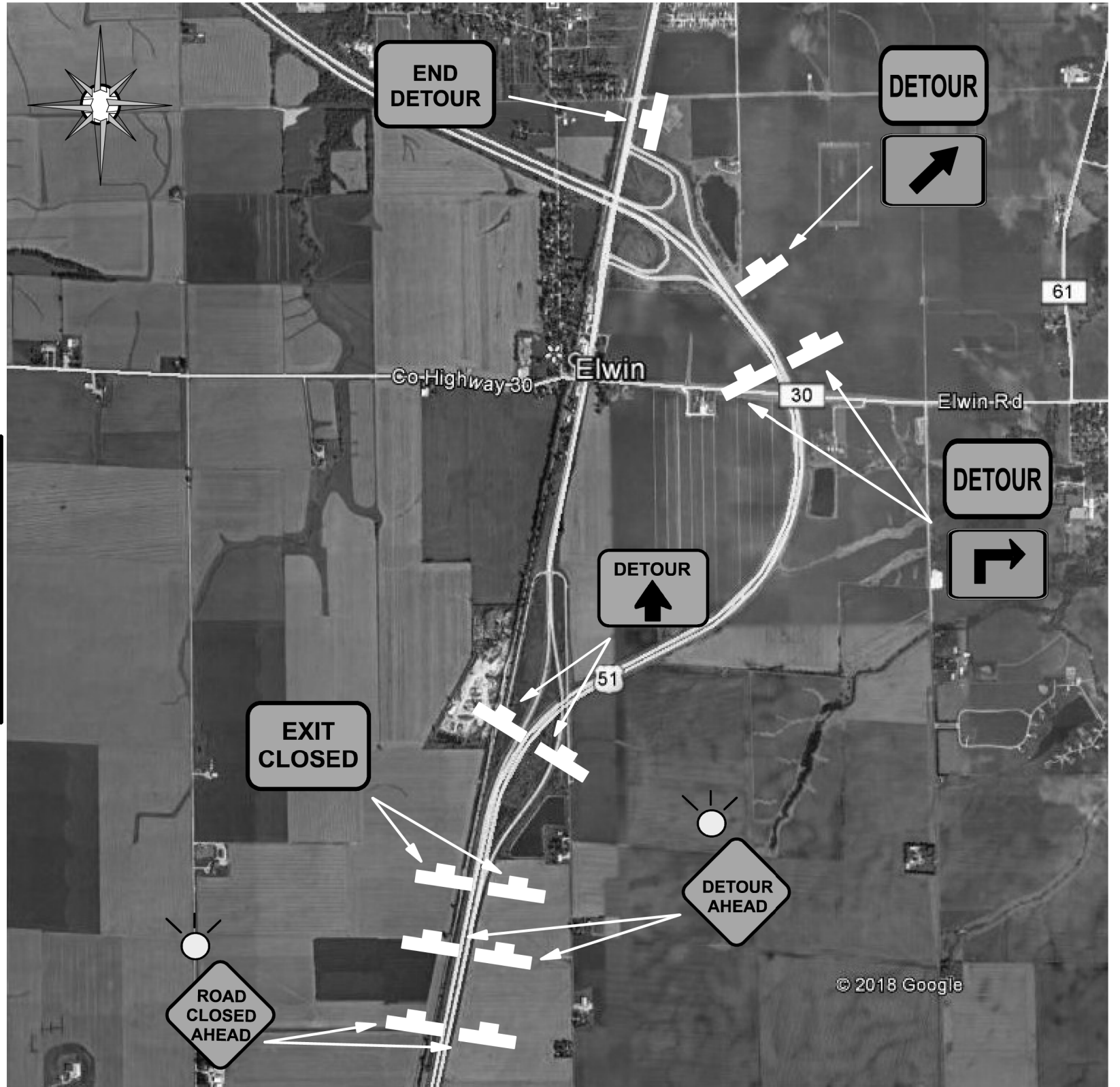

**SIGN LEGEND**

	W20-3(O)-48		M4-8-2412
	W20-2(O)-48		M5-1R(O)-3018
	M4-8a(O)-3024		M4-9(UP)(O)-3024
	E5-2a(O)-4836		M5-2R(O)-3018

Contract No. 74779

MODEL: Default  
 FILE: \\nas01c.psu.edu\pub\baronm.d\at\illinois.gov\PI\DOT\Documents\DOT\_Offices\Distct 7\Projects\74779\CA00DataCAD\chests\074779-shc-detsllk.dgn

USER NAME = steffemk	DESIGNED -	REVISED -
	DRAWN -	REVISED -
PLOT SCALE = 100,0000' / in.	CHECKED -	REVISED -
PLOT DATE = 1/29/2020	DATE -	REVISED -

**STATE OF ILLINOIS  
DEPARTMENT OF TRANSPORTATION**

**DETOUR SIGNING**

SCALE: SHEET OF SHEETS STA. TO STA.

F.A.P. RTE.	SECTION	COUNTY	TOTAL SHEETS	SHEET NO.
322A	(46,47)RS-3, (58-20-1)RS-1	MACON	84	84
CONTRACT NO. 74779				
ILLINOIS FED. AID PROJECT				