

STATE OF ILLINOIS
DEPARTMENT OF TRANSPORTATION

Sheet S14 of S25

F.A.I. RTE.	SECTION	COUNTY	TOTAL SHEETS	SHEET NO.
80	81-IHBY-D	ROCK ISLAND	120	43
FED. ROAD DIST. NO. 2		ILLINOIS	FED. AID PROJECT	

Contract # 64C74

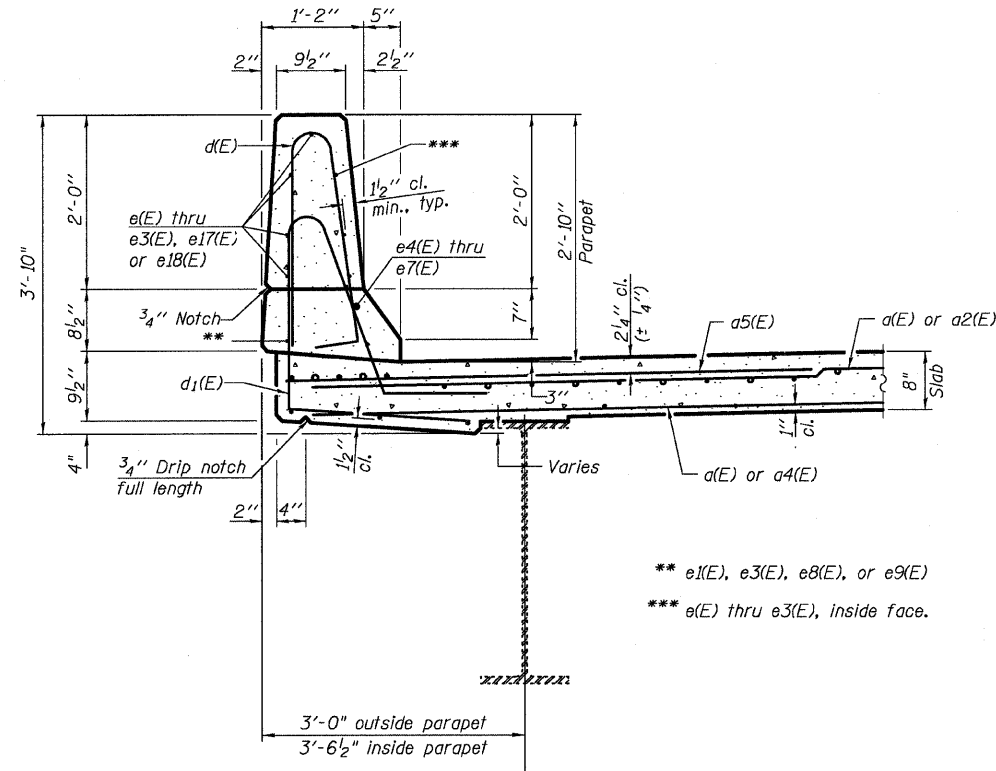

SECTION THRU PARAPET

** e1(E), e3(E), e8(E), or e9(E)
*** e(E) thru e3(E), inside face.

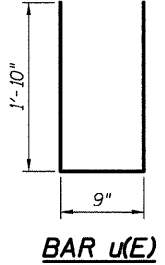

BAR u(E)

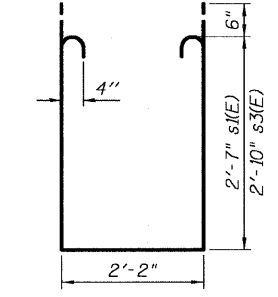

BARS s1(E) & s3(E)

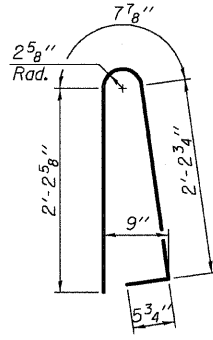

BAR d(E)

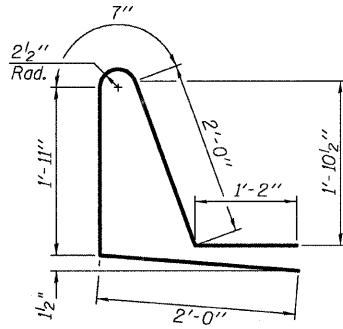

BAR d1(E)

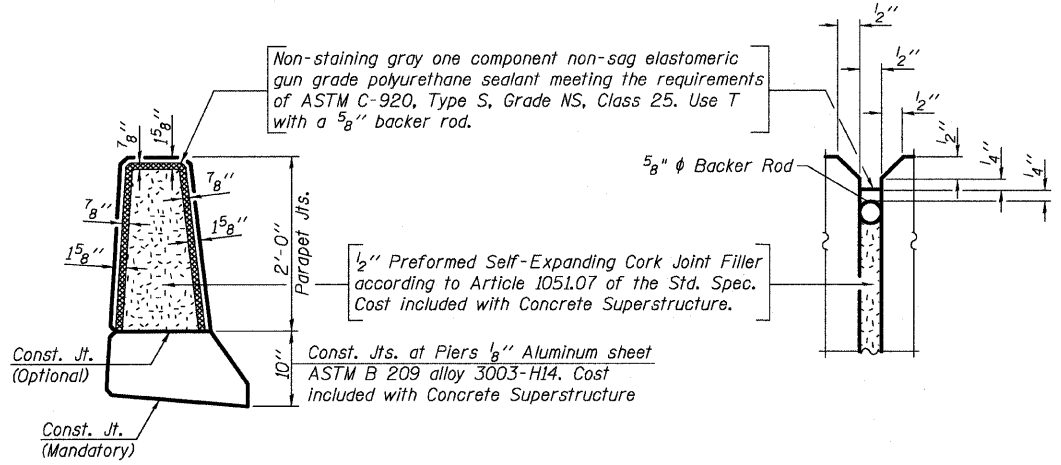

PARAPET JOINT DETAILS

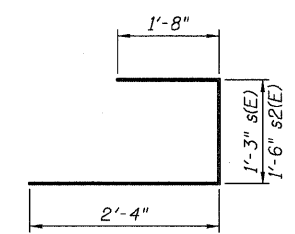

BARS s(E) & s2(E)

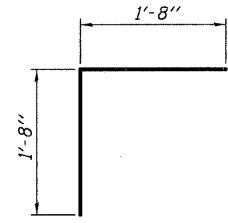

BAR v(E)

SUPERSTRUCTURE
BILL OF MATERIAL

Bar	No.	Size	Length	Shape
a(E)	1264	#5	26'-2"	—
a1(E)	716	#5	10'-11"	—
a2(E)	716	#5	21'-3"	—
a3(E)	548	#5	13'-5"	—
a4(E)	548	#5	18'-9"	—
a5(E)	720	#6	6'-0"	—
a6(E)	8	#5	27'-2"	—
a7(E)	16	#5	16'-7"	—
b(E)	840	#5	29'-1"	—
b1(E)	880	#5	25'-8"	—
b2(E)	336	#6	29'-2"	—
d(E)	848	#5	5'-7"	⌋
d1(E)	848	#5	7'-8"	⌋
e(E)	80	#4	15'-9"	—
e1(E)	128	#4	6'-4"	—
e2(E)	168	#4	14'-0"	—
e3(E)	64	#4	7'-11"	—
e4(E)	8	#8	31'-10"	—
e5(E)	16	#8	6'-4"	—
e6(E)	16	#8	23'-1"	—
e7(E)	8	#8	7'-11"	—
e8(E)	16	#4	16'-10"	—
e9(E)	16	#4	22'-0"	—
e17(E)	16	#4	16'-0"	—
e18(E)	16	#4	15'-4"	—
m(E)	32	#6	27'-4"	—
m1(E)	40	#6	17'-3"	—
m2(E)	32	#6	9'-3"	—
m3(E)	16	#6	7'-11"	—
m4(E)	8	#6	13'-7"	—
m5(E)	8	#6	8'-4"	—
m6(E)	8	#6	3'-4"	—
m7(E)	32	#6	6'-4"	—
m8(E)	8	#6	3'-8"	—
m9(E)	12	#6	8'-1"	—
m10(E)	4	#6	6'-0"	—
m11(E)	8	#6	2'-9"	—
m12(E)	8	#6	2'-3"	—
m13(E)	12	#6	16'-9"	—
m14(E)	12	#6	17'-6"	—
s(E)	164	#5	5'-3"	⌋
s1(E)	136	#4	8'-4"	⌋
s2(E)	84	#5	5'-6"	⌋
s3(E)	76	#4	8'-10"	⌋
u(E)	228	#4	4'-5"	⌋
v(E)	228	#5	3'-4"	⌋
Reinforcement Bars, Epoxy Coated		Pound	174,070	
Concrete Superstructure		Cu. Yds.	726.9	
Bar Splicers		Each	1,560	
Protective Coat		Sq. Yd.	2,618	
Bridge Deck Grooving		Sq. Yd.	2,208	

Bars indicated thus 20 x 3-#5 etc. indicates 20 line of bars with 3 lengths per line.

ILLINOIS DEPARTMENT OF TRANSPORTATION
SUPERSTRUCTURE DETAILS III
PARAPET DETAILS
INTERSTATE 80 OVER INTERSTATE 88
F.A.I. ROUTE 80 - SECTION 81-IHBY-D
ROCK ISLAND COUNTY
STATION 217+81.50
EB S.N. 081-0012 & WB 081-0013
DRAWN BY: A. Durbak
CHECKED BY: R. Koye
DATE: FEBRUARY 27, 2008

FILES
SIZES
REVISED
PATRICK
ENGINEERING INC.
LISLE, ILLINOIS