

STATE OF ILLINOIS
DEPARTMENT OF TRANSPORTATION

ROUTE NO.	SECTION	COUNT	DATE	NO. OF SHEETS
FAP 310		McDONOUGH	14	14
FED. ROAD DIST. NO. 7	ILLINOIS		FID. AID PROJECT	

SHEET NO. 5
5 SHEETS

Contract Number: 68779

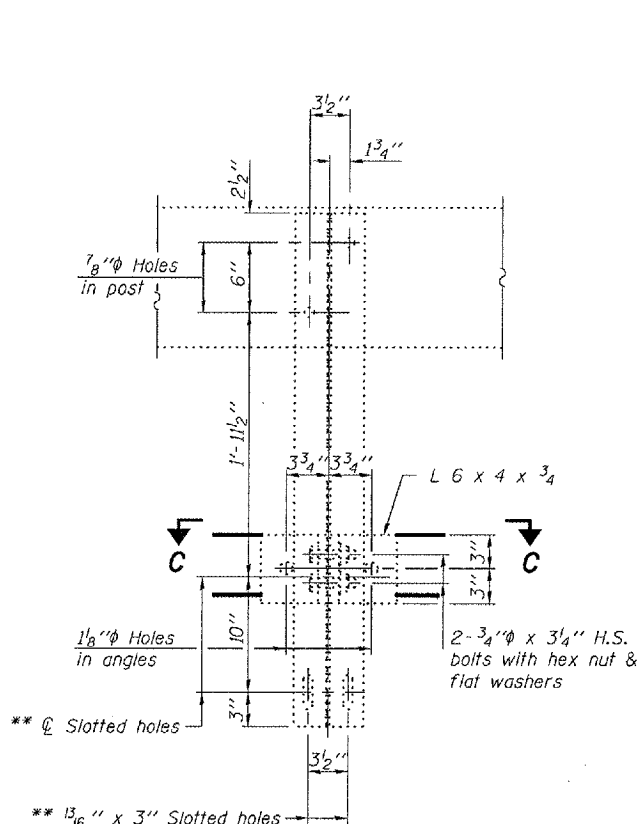

SECTION B-B

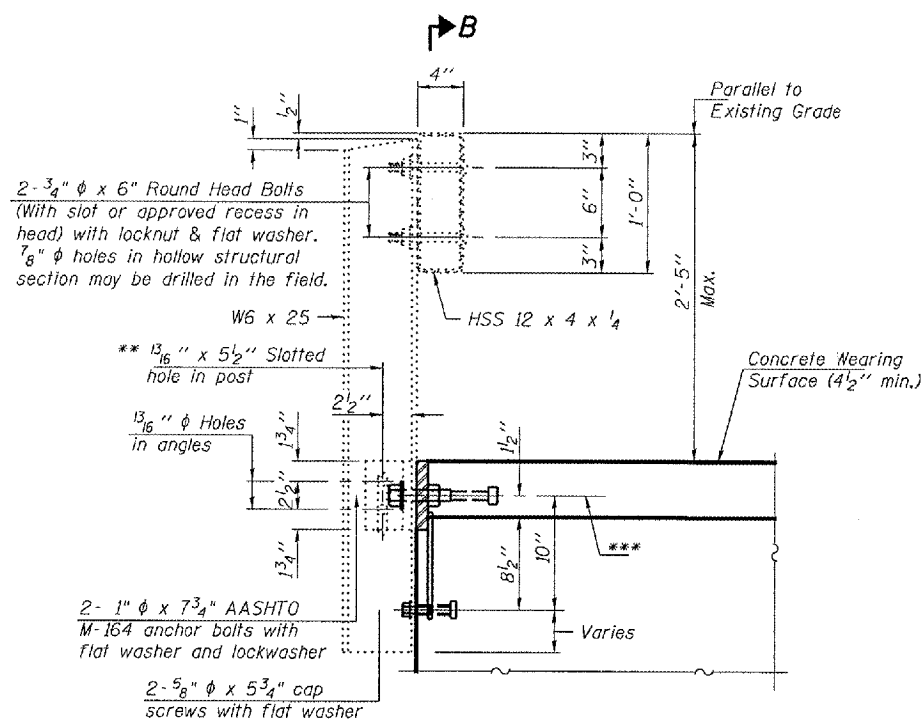

SECTION AT RAILING POST

Notes:
All field drilled holes shall be coated with an approved zinc rich paint before erection.
All steel rail elements shall be galvanized according to Article 509.05 of the Standard Specifications.
Removal and re-erection of the existing railing shall be accomplished in a manner that will avoid scratching, denting or other damage that may affect the durability or appearance of the railing.
The length paid for will be overall length along the rail from end to end, in place, at the location of re-erection.
This work will be paid for at the contract unit price per foot for Removing and Re-erecting Existing Railing, which price shall include removal, temporary storage, re-erection, asphalt paint or new bearing pads, shims, and all new hardware required to satisfactorily complete the work.

*** The studs of the anchor devices shall be placed below the top reinforcement bars and the outermost longitudinal reinforcement bar shall be placed directly above the studs of the rail post anchor device.

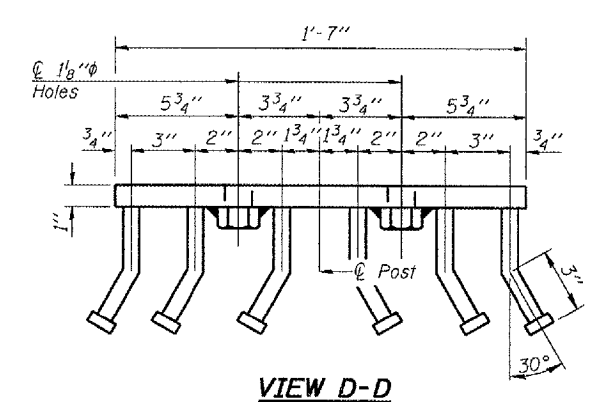

VIEW D-D

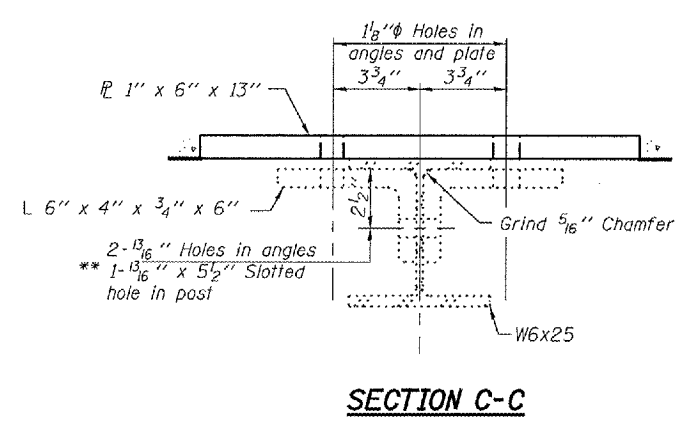

SECTION C-C

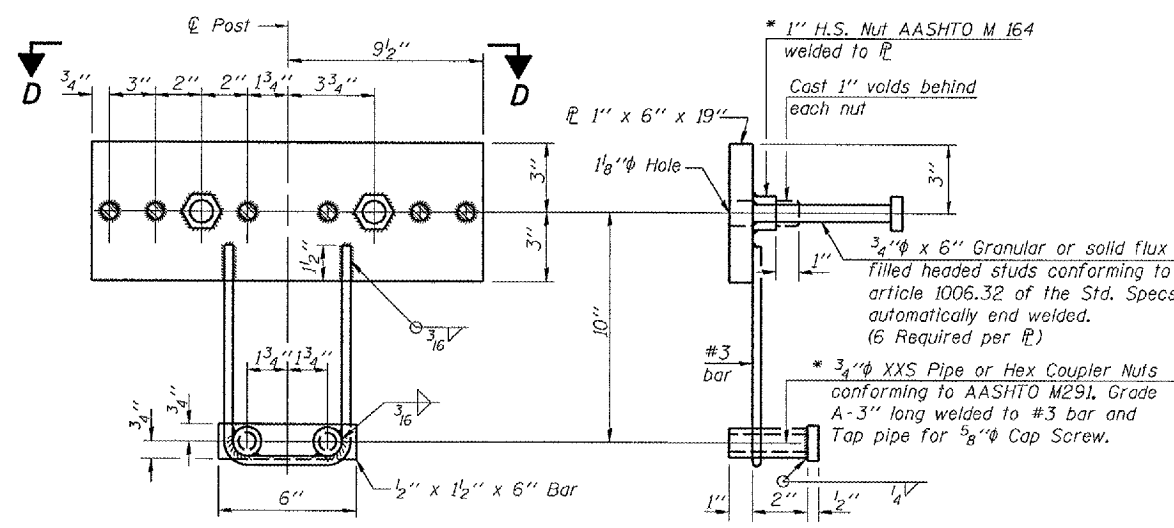

ANCHOR DEVICE

* Threaded areas shall be plugged or blocked off during casting of beam. Galvanized after fabrication.

** Extend slotted holes in Existing Post if required to adjust rail height.

DESIGNED	VHV
CHECKED	ATH
DRAWN	Steffen
CHECKED	VHV

FEBRUARY 26, 2008
EXAMINED *[Signature]*
PASSED *[Signature]*
ENGINEER OF STRUCTURAL SERVICES
ENGINEER OF BRIDGES AND STRUCTURES

REPAIR DETAILS
FAP RT. 310 OVER
FARMERS CREEK
McDONOUGH COUNTY
SN 055-0003