

F.A.P. RTE.	SECTION	COUNTY	TOTAL SHEETS	SHEET NO.
304	5BR-2	CALHOUN	68	5
STA.		TO STA.		
FED. ROAD DIST. NO.		ILLINOIS FED. AID PROJECT		

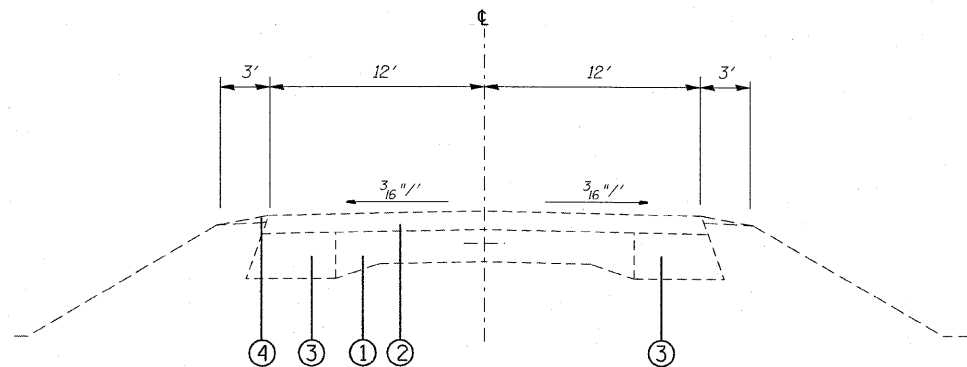

EXISTING TYPICAL SECTION

STA. 463+70.00 TO STA. 471+65.00

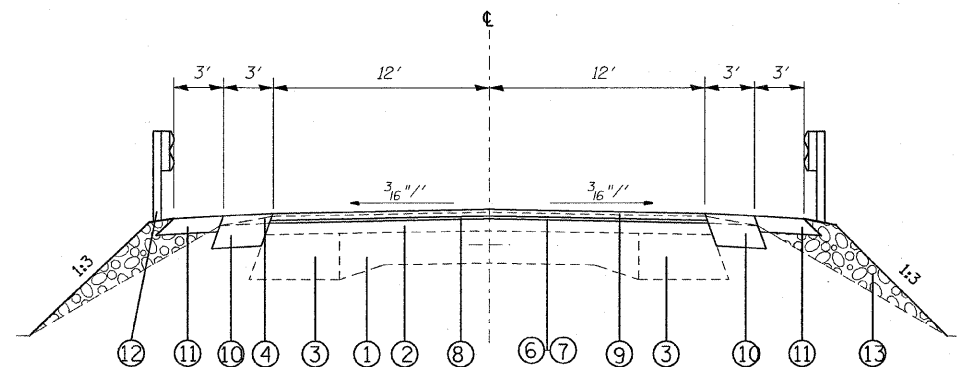

PROPOSED TYPICAL SECTION

STA. 464+15.00 TO STA. 470+15.00

STONE RIPRAP:

STA. 463+58.00 TO STA. 471+13.00 (LT)

STA. 464+15.00 TO STA. 471+05.00 (RT)

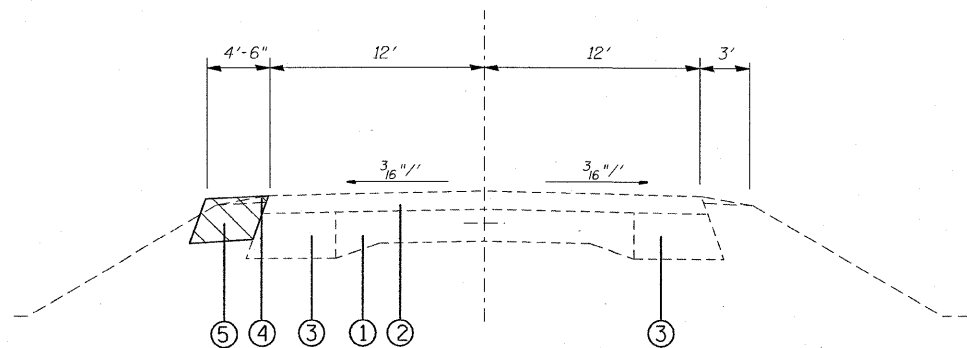

PROPOSED TYPICAL SECTION

STA. 463+70.00 TO STA. 471+21.00 - LT

PAVEMENT REMOVAL

LEGEND

- ① EXISTING P.C.C. PAVEMENT 9-7-9
- ② EXISTING BITUMINOUS OVERLAY 6" (±)
- ③ EXISTING BASE COURSE WIDENING 8"
- ④ EXISTING AGGREGATE SHOULDERS
- ⑤ PROPOSED HOT-MIX ASPHALT BASE COURSE WIDENING, 9"
- ⑥ PROPOSED BITUMINOUS MATERIALS (PRIME COAT)
- ⑦ PROPOSED AGGREGATE (PRIME COAT)
- ⑧ PROPOSED HOT-MIX ASPHALT BINDER COURSE VARIABLE DEPTH (0.75" TO 14.3")
- ⑨ PROPOSED HOT-MIX ASPHALT SURFACE COURSE, 1 1/2"
- ⑩ PROPOSED HOT-MIX ASPHALT SHOULDER, 8 "
- ⑪ PROPOSED AGGREGATE SHOULDER, TYPE B 6"
- ⑫ PROPOSED GUARDRAIL
- ⑬ PROPOSED STONE RIPRAP

MIXTURE REQUIREMENTS

MIXTURE USE	SURFACE	INCIDENTAL SURF	BINDER	WIDENING COURSE	SHOULDERS	TOP LIFT SHOULDERS
AC/PG	PG 64-22	PG 64-22	PG 64-22	PG 64-22	PG 58-22	PG 58-22
RAP % (MAX)	10%	10%	15%	15%	30%	30%
DESIGN AIR VOIDS	4.0% @ Ndes= 70	4.0% @ Ndes=70	4.0% @ Ndes= 70	4.0% @ Ndes= 70	2.0% @ Ndes=30	**2.0% @ Ndes=30
MIX COMPOSITION						
(GRADATION MIXTURE)						
FRICITION AGG	MIXTURE "D"	MIXTURE "C"	MIXTURE "B"	MIXTURE "B"	BAM	BAM

** TOP LIFT SHOULDERS - DESIGN THIS MIX AT 2.0% VOIDS AND ADD ASPHALT TO REDUCE VOIDS TO 1.5%.

PLAN QUANTITIES FOR BITUMINOUS CONCRETE SURFACE COURSE ITEMS ARE CALCULATED USING A UNIT WEIGHT OF 112 LB/SQ YD/IN (59.8 KG/SQ M/25 MM THICKNESS).

REVISIONS	
NAME	DATE

ILLINOIS DEPARTMENT OF TRANSPORTATION
TYPICAL SECTIONS
MIXTURE REQUIREMENT
 FAP ROUTE 304
 SECTION 5BR-2
 CALHOUN COUNTY

SCALE: VERT.
 HORIZ.
 DATE

DRAWN BY
 CHECKED BY