

STATE OF ILLINOIS
DEPARTMENT OF TRANSPORTATION

ROUTE NO.	SECTION	COUNTY	SHEET NO.	SHEET NO.
F.A.U. 6761	#	Tazewell	154	96
FED. ROAD DIST. NO. 7	ILLINOIS	FED. AID PROJECT-		

*Section 04-00057-06-WR

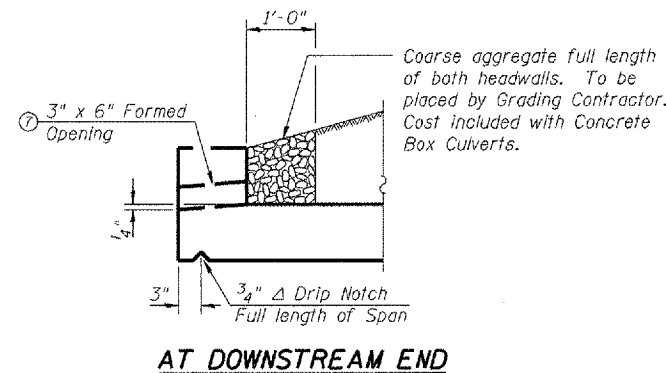
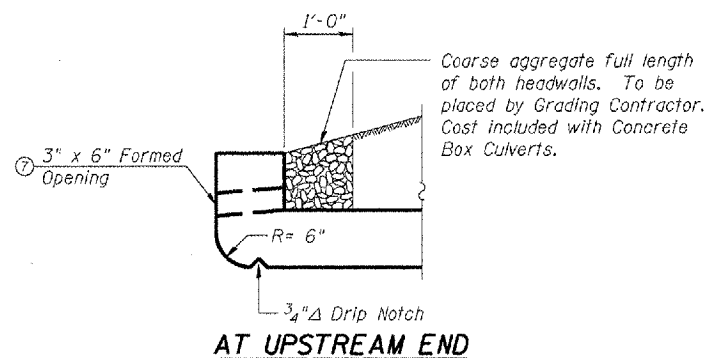

DRAIN DETAIL

⑦ Four 3" H x 6" W formed drain openings thru upstream and downstream headwalls, located at midspan of barrels. Space reinforcing bars to miss openings min. 1/2" clear.

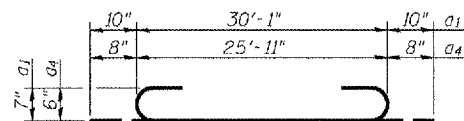

BARS a1 & a4

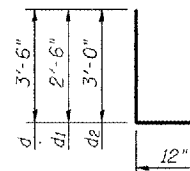

BARS d, d1, & d2

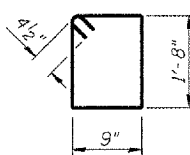

BAR s

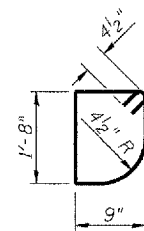

BAR s1

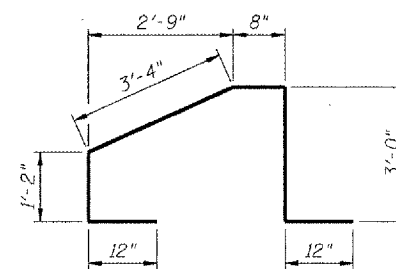

BAR s2

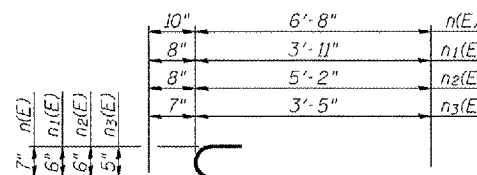

BARS n(E), n1(E), n2(E), & n3(E)

BILL OF MATERIAL

Bar	No.	Size	Length	Shape
a	15	#7	30'-1"	U
a1	22	#7	31'-9"	U
a2	15	#7	29'-11"	U
a3	41	#9	25'-11"	U
a4	110	#6	27'-3"	U
a5	41	#9	25'-9"	U
d	94	#4	4'-6"	L
d1	31	#4	3'-6"	L
d2	31	#6	4'-0"	L
h	108	#6	10'-8"	U
h1	108	#6	33'-10"	U
h2	30	#7	10'-8"	U
h3	24	#6	33'-11"	U
h4	8	#6	29'-5"	U
h5	21	#6	29'-11"	U
h6	23	#4	21'-11"	U
h7	23	#4	12'-5"	U
h8	20	#4	17'-11"	U
h9	20	#4	10'-2"	U
n(E)	37	#7	7'-6"	U
n1(E)	37	#6	4'-7"	U
n2(E)	35	#6	5'-10"	U
n3(E)	35	#5	4'-0"	U
s	93	#4	5'-7"	U
s1	31	#4	5'-5"	U
s2	16	#5	10'-2"	U
t	79	#4	7'-11"	U
t1	88	#4	6'-8"	U
v	45	#6	10'-6"	U
v1	178	#6	4'-3"	U
v2	141	#6	8'-6"	U
v3	37	#5	11'-0"	U
v4	10	#4	14'-3"	U
v5	35	#5	10'-6"	U
v6	8	#4	12'-0"	U
v7	8	#6	7'-0"	U
w	12	#5	21'-10"	U
w1	12	#5	12'-4"	U
w2	10	#5	10'-1"	U
w3	10	#5	17'-10"	U
Concrete Box Culverts	Cu. Yd.		215.2	
Reinforcement Bars	Pound		33,900	
Reinforcement Bars, Epoxy Coated	Pound		1,270	
Name Plates	Each		1	
3/4" φ Expansion Bolts	Each		116	

**BILL OF MATERIAL
AND BAR BENDS**
F.A.U. RT. 6761
LICK CREEK TRIBUTARY
SECTION 04-00057-06-WR
TAZEWELL COUNTY, STA. 73+39.50
STRUCTURE NO. 090-5004

DESIGNED	PJL
CHECKED	LLV
DRAWN	MGM
CHECKED	PJL

STS CONSULTANTS
111 NE Jefferson Ave.
Peoria, Illinois 61602
Ph(309)676-8464
FAX(309)676-5445
IL Design Firm Reg. No. 184-001518