

ROUTE	SECTION	COUNTY	TOTAL SHEETS	SHEET NO.
	06-00054-00-SW	FRANKLIN	8	8
WEST FRANKFORT		MAIN STREET		

CONTRACT NO. 99302  
PROJECT NO. TE-00D9(93)

**BROWN AND ROBERTS, INC.**  
CONSULTING ENGINEERS & LAND SURVEYORS  
1 WEST RIDGE ROAD HARRISBURG, IL 62946 (618) 252-8111

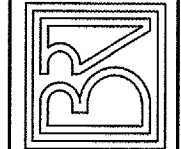

CITY OF WEST FRANKFORT  
STREETSCAPE IMPROVEMENTS  
TYPICAL DETAILS

Drawn By:	Checked By:
ECB	MWR
Revisions	
Item	Date By
Scale:	Field Bk:
AS SHOWN	
Job Number:	Date:
05-136	03/2007
Sheet	

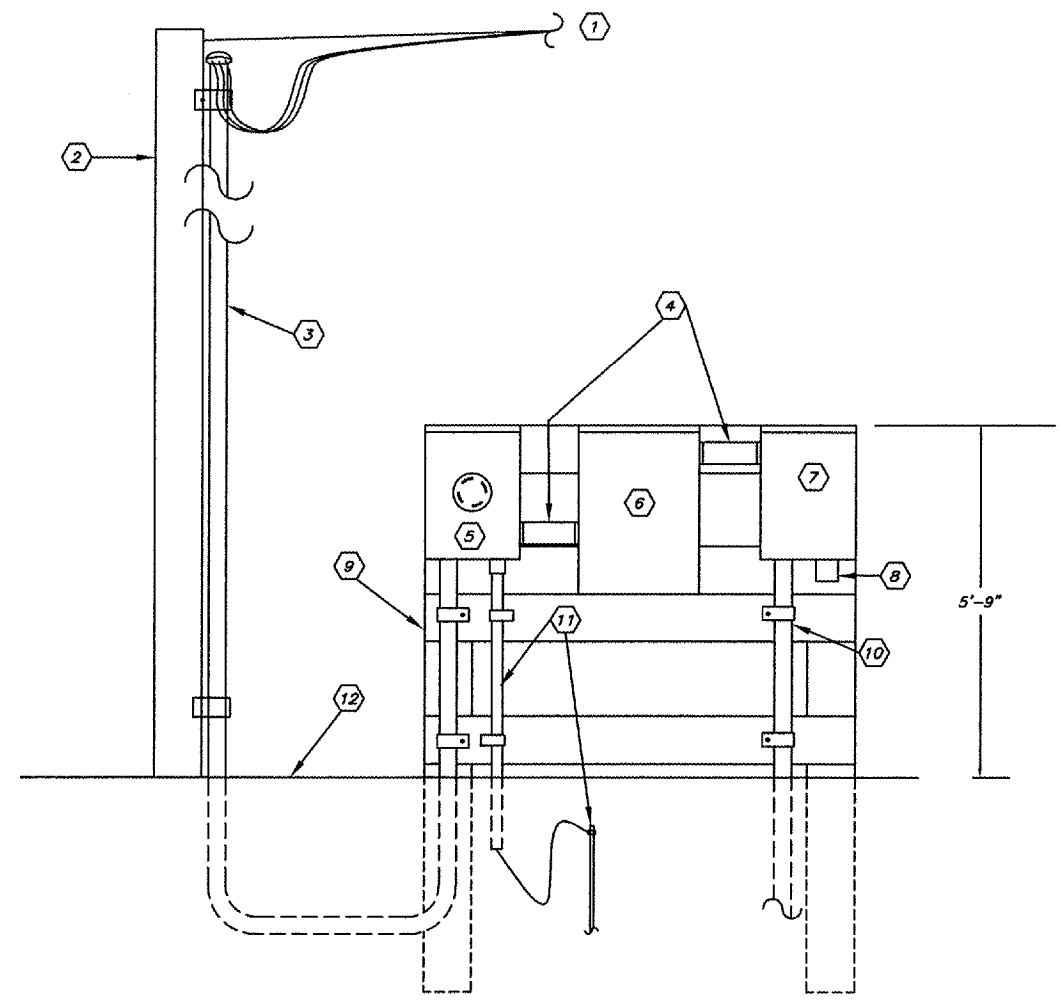

**SERVICE AND CONTROL EQUIPMENT**  
NO SCALE

- DETAIL NOTES**
- ① OVERHEAD 100 AMP, 120/240 VOLT SERVICE DROP BY AMEREN CIPS.
  - ② EXISTING UTILITY POLE
  - ③ STUB SERVICE RISER UP POLE TO HEIGHT REQUIRED BY AMEREN AND TERMINATE WITH A WEATHERHEAD.
  - ④ SEE 1-LINE DIAGRAMS, THIS SHEET.
  - ⑤ 100 AMP, 120/240 VOLT, SINGLE PHASE METER BASE BY CONTRACTOR TO AMEREN STANDARDS.
  - ⑥ MAIN DISTRIBUTION PANEL (MDP) - 100 AMP, 120/240 VOLT, SINGLE PHASE, 3-WIRE S/N, 20 CIRCUIT, NEMA 3R LOAD CENTER -- SQUARE D #QO120M100RB, OR EQUAL. PROVIDE TYPE QO BRANCH BREAKERS PER SYSTEM 1-LINE DIAGRAM, THIS SHEET.
  - ⑦ CONTACTOR PANEL SHALL CONSIST OF TWO SIZE 1, 4-POLE, OPEN LIGHTING CONTACTORS WITH 120 VOLT COIL - SQUARE D, CLASS 8903, #LO40VD2, OR EQUAL. ENCLOSURE SHALL BE NEMA 4X, 12" x 14" x 6" MINIMUM SIZE, WITH MOUNTING PANEL, AND SHALL BE LOCKABLE.
  - ⑧ 1800 WATT, 120 VOLT, SPST, PHOTOCONTROL - PARAGON #LB201, OR EQUAL. MOUNT IN BOTTOM OF PANEL TO FACE DOWN.
  - ⑨ TREATED WOOD MOUNTING FRAME SHALL CONSIST OF TWO 6"x6"x9' POSTS, AND SUFFICIENT NUMBER OF 2X6 CROSS-MEMBERS TO PROVIDE TOP AND BOTTOM SUPPORT FOR ALL ENCLOSURES PLUS CONDUIT FASTENING AS SHOWN. LOCATE FRAME WITHIN FOUR FEET OF EXISTING UTILITY POLE. SETBACK FROM CURB LINE SHALL BE DIRECTED BY THE ENGINEER.
  - ⑩ 1" PVC FOR BRANCH WIRING. SEE SYSTEM 1-LINE DIAGRAM, THIS SHEET. SEE SHEET 5 FOR CONTINUATION.
  - ⑪ 1 - #6 STRANDED COPPER GROUNDING ELECTRODE CONDUCTOR IN 1/2" SCHEDULE 80 PVC FROM NEUTRAL BUS TO 5/8" X 8' GROUND ROD DRIVEN 1' TO THE TOP BELOW GRADE.
  - ⑫ SAW CUT, REMOVE AND REPLACE EXISTING CONCRETE AS REQUIRED FOR UNDERGROUND SERVICE AND BRANCH WIRING.

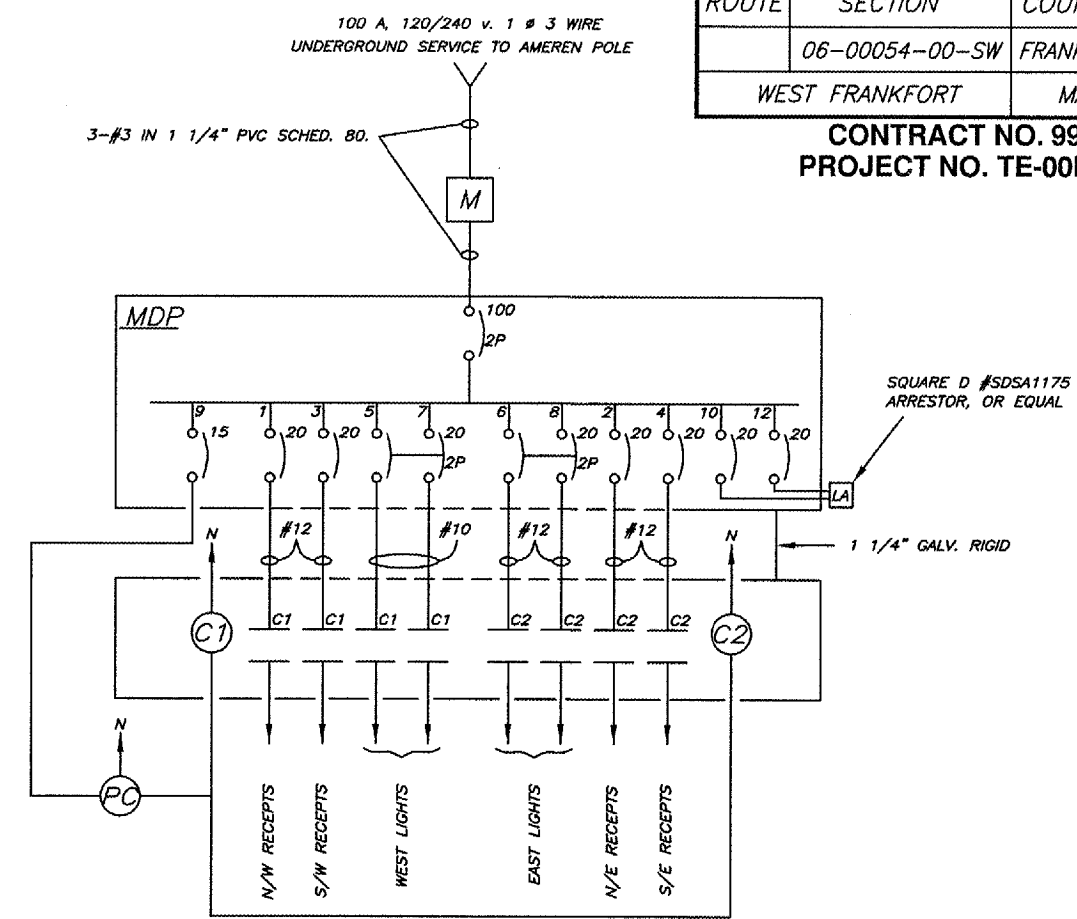

**SYSTEM 1 - LINE DIAGRAM**

MARK	PHASE COND.	PHASE COND. QUAN.	EQUIP. GRND.*	CONDUIT SIZE
①	#10	5	#10	3/4"
②	#10	10	#10	1"
③	#10	4	#10	3/4"

\* BOND THIS EGC TO THE INDIVIDUAL GROUND ROD AT EACH LIGHT FOUNDATION, SEE DETAIL, THIS SHEET.

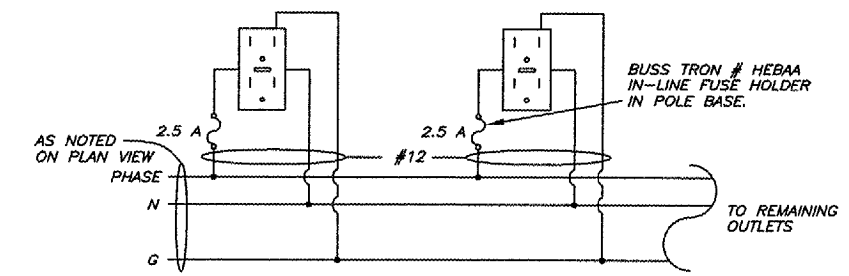

**DUPLEX GFI RECEPT PHASE DISTRIBUTION**

31 Jan 2008 - 9:55am \\Server6\shared\2005\05136\oc\plans\quantity and detail sheets.dwg: Layout Tab Model