

**JOINTING AT SKEWED EDGE**  
 N.T.S.

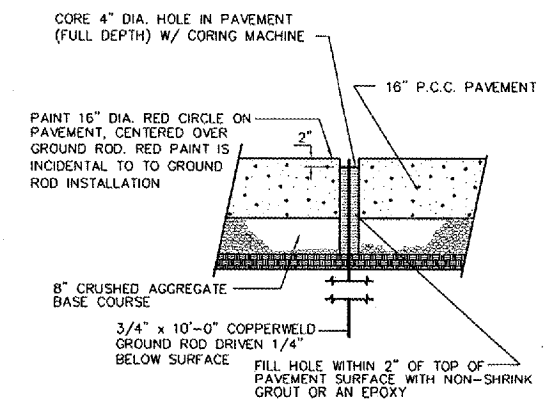

**GROUND ROD DETAIL**  
 NO SCALE

| REVISIONS |    |      |
|-----------|----|------|
| NUMBER    | BY | DATE |
|           |    |      |
|           |    |      |
|           |    |      |

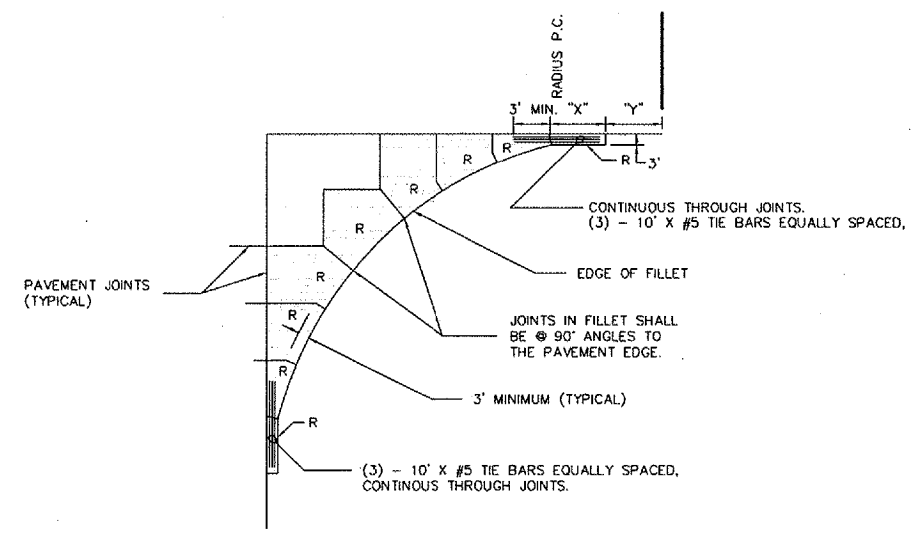
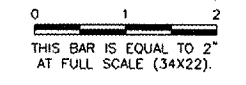

**FILLET DETAIL AND FILLET REINFORCING LAYOUT**  
 N.T.S.

Ⓡ DENOTES ODD SHAPED REINFORCED PANELS TO BE REINFORCED WITH DEFORMED WIRE FABRIC AS SHOWN ON JOINTING DETAILS SHEET. ALL NON RECTANGULAR SHAPED PANELS SHALL BE REINFORCED. (REINFORCEMENT NOT SHOWN)

| FILLET RADIUS | "X" (IN FEET) | "Y" (IN FEET) |
|---------------|---------------|---------------|
| 20            | 4.30          | 6.24          |
| 25            | 4.88          | 7.00          |
| 30            | 5.40          | 7.68          |
| 50            | 7.11          | 9.95          |
| 75            | 8.79          | 12.21         |
| 85            | 9.38          | 13.00         |
| 100           | 10.21         | 14.11         |
| 125           | 11.44         | 15.78         |
| 150           | 12.56         | 17.29         |
| 175           | 13.58         | 18.68         |
| 200           | 14.53         | 19.98         |

**CHICAGO ROCKFORD INTERNATIONAL AIRPORT  
 ROCKFORD, ILLINOIS**

**JOINTING DETAILS - SHEET 2**

© Copyright: CMT, Inc.  
**CMT**  
 CRAWFORD, MURPHY & TILLY, INC.  
 CONSULTING ENGINEERS  
 License No. BR-000613

**Chicago Rockford International Airport**

|  |           |
|--|-----------|
| DESIGN BY:   | DKP / JRL |
| DRAWN BY:  | JRO       |
| CHECKED BY:  | CAL       |
| APPROVED BY:   |           |
| DATE:  | 02/29/08  |
| JOB No:  | 07258-06  |
| ILLINOIS PROJECT: RFD-3787<br>A.I.P. PROJECT: 3-17-0088-XX |           |
| <b>FINAL SUBMITTAL</b>                                     |           |
| SHEET 16 OF 83 SHEETS                                      |           |