

1-PH COMPT TR PAD - ESS/RSS 167KVA MAXIMUM CAPACITY

ITEM	MATERIAL DESCRIPTION (BY ComEd)	MIG	SI	UNIT	QTY
A	GROUNDING INSTALLATION (1) C8550_G0	G			1
C	Wire, Copper; #1/0-19 Strand, Soft Drawn, Tin Coated, Bare, (1)	G	355082	FT	35
D	Connector, Compression; 1/0 Or 2/0 Strd Cu. Run & Tap,	U	368545	EA	1

NOTES:

APPLICATION

- THIS STANDARD SHALL BE USED FOR THE INSTALLATION OF AN ELECTRIC OR RESIDENTIAL SERVICE STATION FOUNDATION AS DESCRIBED IN THE "INFORMATION AND REQUIREMENTS FOR THE SUPPLY OF ELECTRIC SERVICE BOOK", SECTIONS 2.02 AND 2.07.

SUPPLEMENTARY MATERIAL

- WHEN BARE LEAD COVERED CABLES ARE LOCATED OR PLANNED WITHIN 200 FEET, OMIT ITEM "C" AND REPLACE WITH 1/0 LEAD CLAD COPPER CONDUCTOR (SI 360809). SPECIFY STAINLESS STEEL GROUNDS PER C8550.G0.
- PRECAST ALTERNATIVES TO THIS POURED DESIGN MAY BE AVAILABLE. CONTACT CONSTRUCTION STANDARDS GROUP.

INFORMATION

- THE CUSTOMER TO INSTALL THE TRANSFORMER FOUNDATION, 1 INCH CONDUITS, AND TRENCH FOR ComEd GROUND WIRE.
- ComEd TO PROVIDE AND INSTALL THE GROUND WIRE AND GRID.
- AFTER PRIMARY AND SECONDARY CONDUITS ARE IN PLACE, BACKFILL WITH SCREENINGS, SAND, OR FINE EXCAVATED MATERIAL. COMPACT THOROUGHLY BEFORE POURING FOUNDATION.
- CONCRETE TO BE IN ACCORDANCE WITH THE LATEST EDITION OF THE APPLICABLE ACI CODE AND AIR ENTRAINED. IT SHALL HAVE A MINIMUM COMPRESSIVE STRENGTH OF 3000 PSI AT 28 DAYS. AIR ENTRAINMENT SHALL BE 4 TO 7 PERCENT OF THE VOLUME OF CONCRETE.

- TOP OF FOUNDATION TO BE SMOOTH AND LEVEL.
- GRADE AWAY FROM FOUNDATION. FINAL GRADE SHALL BE WELL DRAINED AT ALL TIMES.
- PRIMARY AND SECONDARY CONDUIT MUST COME THROUGH FOUNDATION IN DESIGNATED AREAS.
- SEE C7723 FOR BURNDY-HUSKY DIE SET CROSS REFERENCE.
- DO NOT PLACE CONDUITS UNDER THIS SECTION OF FOUNDATION IF AVOIDABLE.
- DO NOT DISTURB EARTH IN FOUNDATION AREA MORE THAN NECESSARY WHEN INSTALLING CONDUIT.
- TERMINATE PRIMARY AND SECONDARY CONDUITS FLUSH WITH TOP OF FOUNDATION.
- BOX OUT CONDUIT OPENING.
- SECONDARY CONDUIT LOCATION.
- PRIMARY CONDUIT LOCATION.
- PLEASE CONSULT GP 346 (SPCC) OR ENVIRONMENTAL SERVICES IF EITHER OF THE FOLLOWING EXISTS:
 - A SINGLE ABOVE GROUND TANK WITH A CAPACITY OF 660 GALLONS OR MORE.
 - MORE THAN ONE ABOVE GROUND TANK WITH TOTAL CAPACITY EQUAL TO OR EXCEEDING 1320 GALLONS.

ITEM	TOOL & DIE	NO. OF CRIMPS
	Y-35	
D	U-O	1
	U-E	3



NORTH ARROW

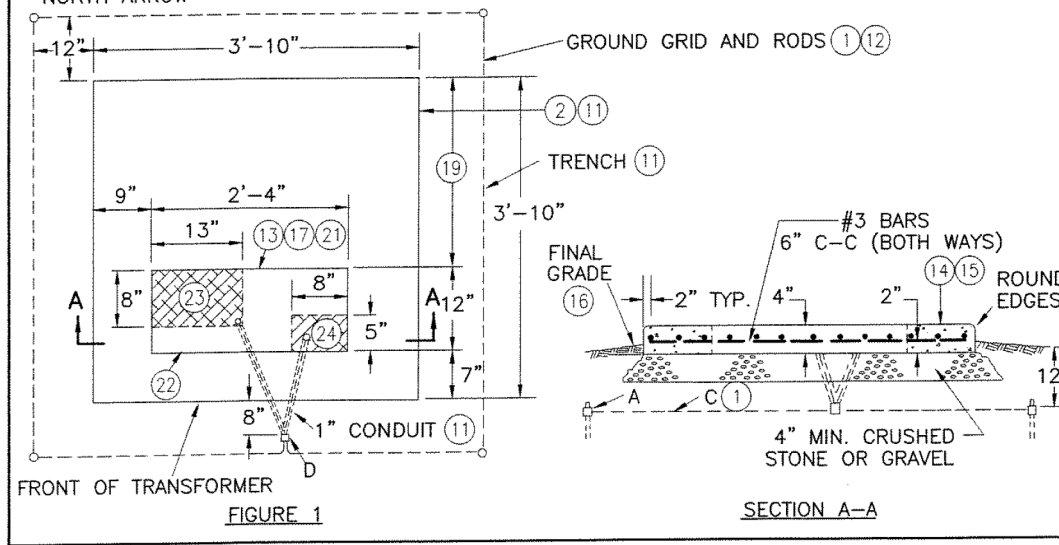

FIGURE 1

SECTION A-A

ACAD

© Notice: The information contained on this page is the sole property of ComEd and is to be used only in conjunction with electric service provided by ComEd.

ComEd SYSTEM STANDARD

NOTES:

- THIS WORK SHALL BE INSTALLED UNDER THE "ELECTRIC SERVICE INSTALLATION" PAY ITEM, UNLESS NOTED OTHERWISE.
- COMMONWEALTH EDISON COMPANY (COMED) SHALL FURNISH AND INSTALL THE PAD MOUNTED TRANSFORMER COMPLETE WITH GROUNDING SYSTEM INCLUDING GROUND RODS, GROUNDING CONDUCTOR, PRIMARY CABLE, CUT-OUT SWITCH, LIGHTNING ARRESTOR, CONNECTORS, AND ANY OTHER EQUIPMENT AND LABOR DEEMED NECESSARY. SEE COMED SYSTEM STANDARD C5288 FOR INSTALLATION REQUIREMENTS.
- ELECTRIC SERVICE CONDUCTORS FROM THE INSIDE OF THE CABINET TO THE TRANSFORMER. PROVIDE 10 FT OF SLACK FOR CONNECTION TO TRANSFORMER BY COMED. CABLE SHALL CONFORM TO THE REQUIREMENTS SPECIFIED FOR ELECTRIC CABLE IN CONDUIT. LABEL CABLE ON BOTH ENDS. SEE PLAN DRAWINGS FOR CABLE TYPE AND SIZE.
- UNDERGROUND CONDUIT. SEE PLAN DRAWINGS FOR CONDUIT MATERIAL AND SIZE.
- RGC 90 DEGREES LONG SWEEP ELBOW IN TRENCH, SEE PLAN DRAWINGS FOR CONDUIT, TYPE, SIZE, AND QUANTITY. THIS WORK SHALL BE INSTALLED UNDER THE "ELECTRIC SERVICE INSTALLATION" PAY ITEM.
- UNDER THE "ELECTRIC UTILITY SERVICE CONNECTION" PAY ITEM, COMED SHALL FURNISH AND INSTALL METER ON CONTROLLER CABINET.
- SEE DRAWING E-21 FOR LIGHTING CONTROLLER AND FOUNDATION DETAILS.
- SUBMIT A PLAN DRAWING SHOWING THE PROPOSED PRIMARY CONDUIT INSTALLATION TO COMED FOR THEIR APPROVAL. THIS WORK SHALL BE COVERED UNDER THE "ELECTRIC UTILITY SERVICE CONNECTION" PAY ITEM. SEPARATE PAYMENT WILL NOT BE MADE.
- COORDINATE DETAILS WITH COMED. FOR BID, ASSUME 200 FEET OF 4" DIA. UNDERGROUND RGC WITH 3-1/C #2/0 12KV CABLES.

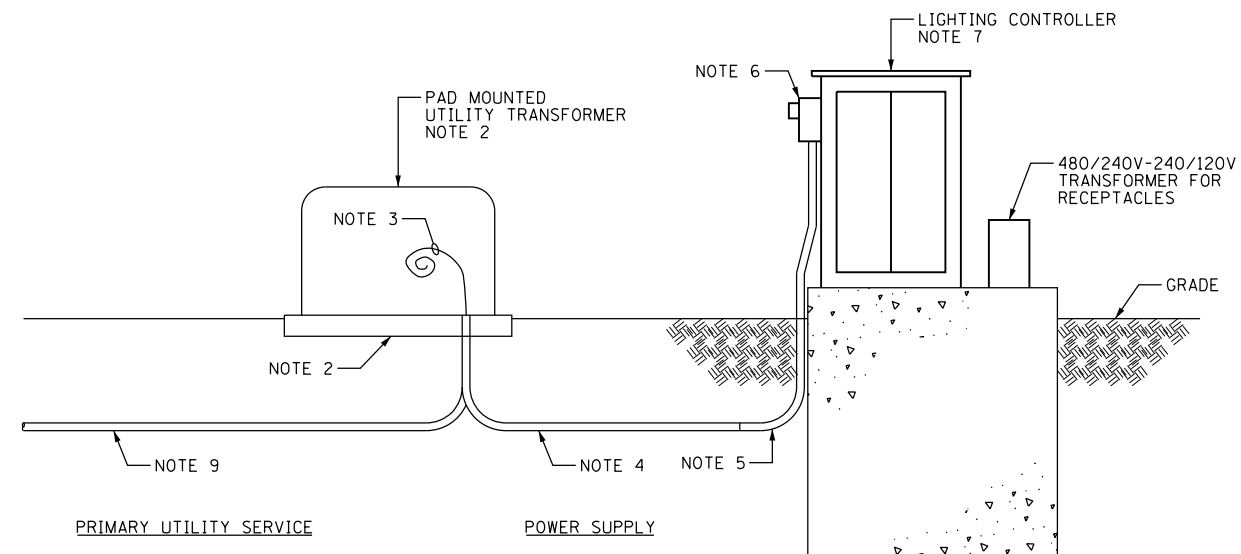

ELECTRIC SERVICE INSTALLATION DETAIL
N.T.S.

FILE NAME = D160F05-SHT-E24.dgn	USER NAME = Frank.Stallone	DESIGNED - MAE	REVISED -
SHT.PLAN	PLOT SCALE = 2:8.000000 '1' / in.	DRAWN - WM	REVISED -
	PLOT DATE = 3/14/2013	CHECKED - DAD	REVISED -
		DATE - 03/13/13	REVISED -

F.A.P. RTE.	SECTION	COUNTY	TOTAL SHEETS	SHEET NO.
330	103R-3	COOK	932	550
E-24			CONTRACT NO. 60F05	
ILLINOIS FED. AID PROJECT				