

EXISTING TYPICAL SECTION  
HARRISON STREET  
STA. 2+62 TO STA. 39+18

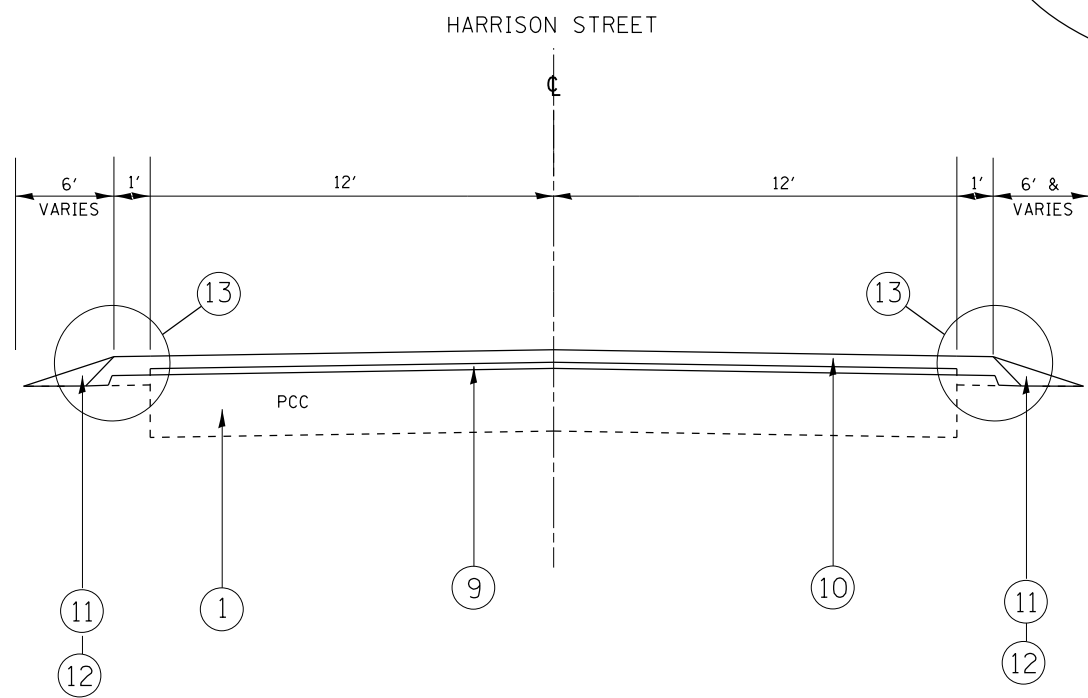
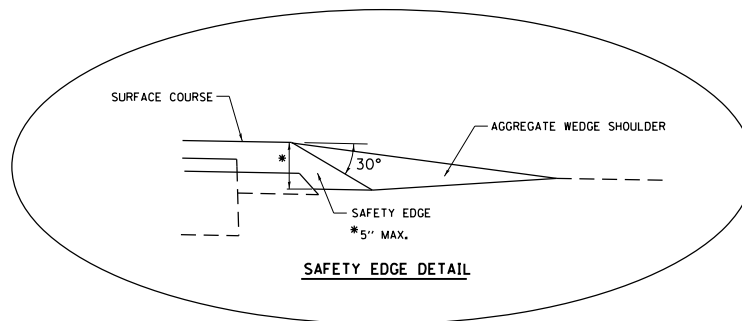

PROPOSED TYPICAL SECTION  
HARRISON STREET  
STA. 2+62 TO STA. 39+18

**LEGEND:**

- ① EXISTING PCC BASE COURSE, 10" (±)
- ② EXISTING CURB & GUTTER
- ③ EXISTING HOT-MIX ASPHALT SURFACE, 3" (±)
- ④ EXISTING HOT-MIX ASPHALT BASE, 7"(±)
- ⑤ EXISTING AGGREGATE SHOULDERS
- ⑥ EXISTING HOT-MIX ASPHALT SAFETY SHOULDER
- ⑦ PROPOSED HOT-MIX ASPHALT SURFACE REMOVAL, 3"
- ⑧ PROPOSED HOT-MIX ASPHALT SURFACE REMOVAL, 2"
- ⑨ PROPOSED POLYMERIZED LEVELING BINDER (MACHINE METHOD), IL-4.75, N50, 1"
- ⑩ PROPOSED HOT-MIX ASPHALT SURFACE COURSE, MIX "D", N50, 2"
- ⑪ PROPOSED AGGREGATE WEDGE SHOULDER, TYPE B
- ⑫ PROPOSED GRADING AND SHAPING SHOULDERS
- ⑬ PROPOSED SAFETY EDGE (SEE DETAIL)

NOTE  
THE CONTRACTOR SHALL PATCH THE ROADWAY:  
BEFORE MILLING: FROM STATION 4+90± TO STATION 46+00±  
AFTER MILLING: FROM STATION 0+77 TO STATION 4+90± AND  
FROM STATION 46+00± TO STATION 60+04.6

HOT-MIX ASPHALT MIXTURE REQUIREMENTS	
MIXTURE TYPE	AIR VOIDS at Ndes
PAVEMENT RESURFACING	
* HOT-MIX ASPHALT SURFACE COURSE, MIX "D", N50 (IL-9.5MM)	3.0% at 50 GYR.
POLYMERIZED LEVELING BINDER (MM), IL-4.75, N50	3.5% at 50 GYR.
PATCHING	
CLASS D PATCHES, HMA BINDER IL-19 MM	4% at 70 GYR.
HMA REPLACEMENT OVER PATCHES (HMA BINDER IL-19 mm)	4% at 70 GYR.

\*SEE SPECIAL PROVISION

**NOTE:**

THE UNIT WEIGHT USED TO CALCULATE ALL HMA SURFACE MIXTURE QUANTITIES IS 112 LBS./SQ. YD./IN.

THE "AC TYPE" FOR POLYMERIZED HMA MIXES SHALL BE "SBSSBR PG 76-22" AND FOR NON-POLYMERIZED HMA THE "AC TYPE" SHALL BE "PG 64-22" UNLESS MODIFIED BY DISTRICT ONE SPECIAL PROVISIONS..

FOR USE OF RECYCLED MATERIALS SEE SPECIAL PROVISIONS.

FILE NAME =	USER NAME = pencepl	DESIGNED -	REVISED -
et:\pw\work\p1dot\pencepl\d0251727\0133711-sht-plen.dgn		DRAWN -	REVISED -
		CHECKED -	REVISED -
		DATE -	REVISED -

STATE OF ILLINOIS  
DEPARTMENT OF TRANSPORTATION

HARRISON STREET-ILL 38 (ROOSEVELT ROAD) TO WOLF ROAD  
EXISTING AND PROPOSED TYPICAL SECTIONS

SCALE: SHEET NO. OF SHEETS STA. TO STA.

F.A.U. RTE.	SECTION	COUNTY	TOTAL SHEETS	SHEET NO.
1427	3205B-R5-1	COOK	22	5
			CONTRACT NO. 60N67	
ILLINOIS FED. AID PROJECT				