

INDEX OF SHEETS

- S1. General Plan and Elevation
- S2. General Notes, Bill of Materials, Index of Sheets, and Details

GENERAL NOTES

1. Plan dimensions and details relative to existing plans are subject to nominal construction variations. The Contractor shall field verify existing dimensions and details affecting new construction and make necessary approved adjustments prior to construction or ordering of materials. Such variations shall not be cause for additional compensation for a change in scope of the work, however, the Contractor will be paid for the quantity actually furnished at the unit price bid for the work.
2. Staged construction shall be utilized to maintain traffic during construction. See Civil Drawings.
3. The Contractor shall exercise care during removal of existing joints to ensure that the slab, beams and diaphragms' integrity will not be detrimentally impacted. The Contractor shall repair any damage(s) to the slab, beams or diaphragms caused by his operation as directed by the Engineer at no additional cost to the Department.
4. Joint openings shall be adjusted according to Article 520.04 of the Std. Specs. when the deck is poured at an ambient temperature other than 50° F.
5. Cost for removal and disposal of existing expansion joints is included in the cost of Silicone Joint Sealer, 2 1/2".
6. The Contractor must take extra care to achieve proper bondage at the ends of the joint repair to the existing joint assembly.

BILL OF MATERIAL

ITEM DESCRIPTION	UNIT	QUANTITY
Concrete Removal	Cu. Yd.	0.1
Silicone Joint Sealer, 2 1/2"	Foot	6.0
Polymer Concrete	Cu. Ft.	1.9

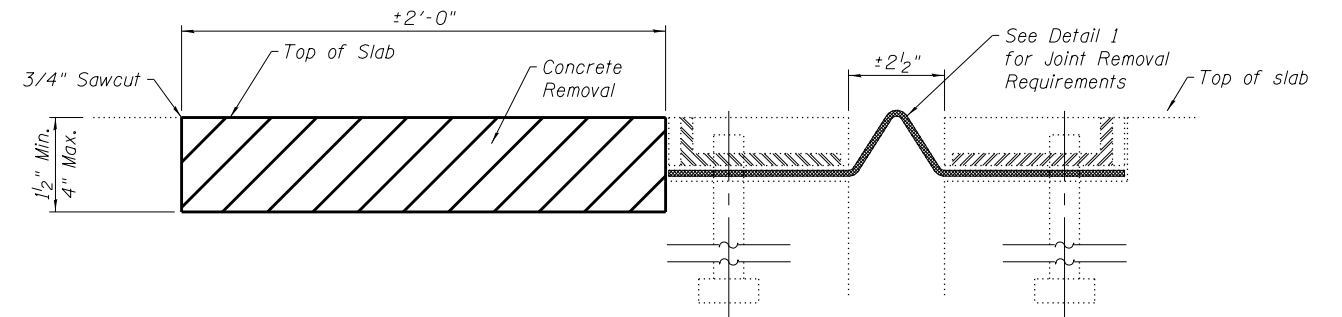

EXISTING CONDITIONS

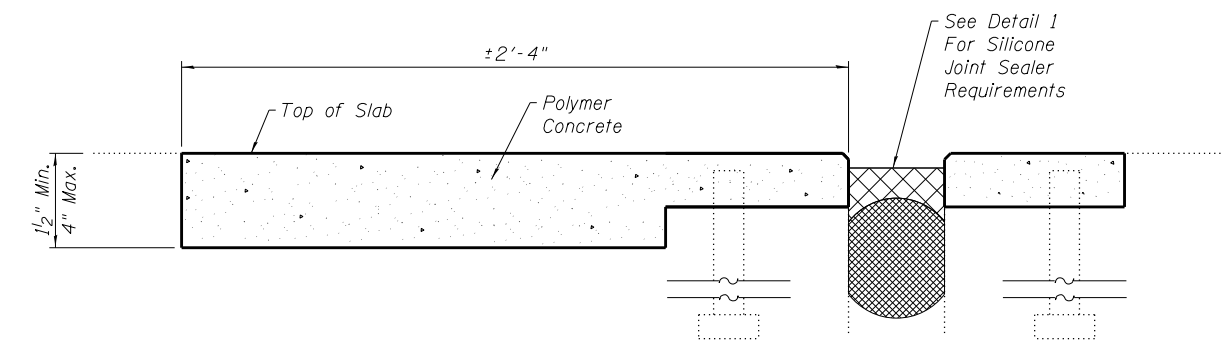

PROPOSED CONDITIONS

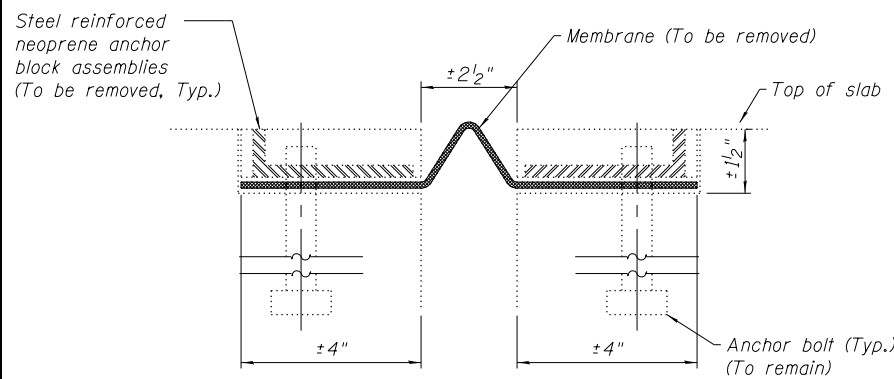

SECTION THROUGH EXISTING NEOPRENE JOINT

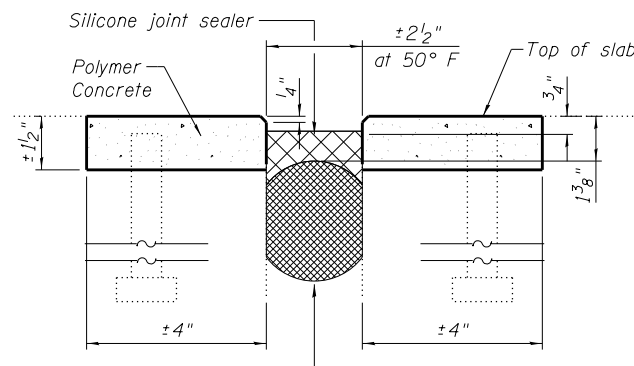

SECTION THROUGH PROPOSED SILICONE JOINT SEALER

DETAIL 1

DETAIL 2

USER NAME =	DESIGNED - AMS	REVISED -
DRAWN - AMS	REVISED -	
PLOT SCALE =	CHECKED - JMH	REVISED -
PLOT DATE =	DATE - DECEMBER 2012	REVISED -

F.A.I. RTE. 90/94	SECTION 2012-055BR	COUNTY COOK	TOTAL SHEETS 107	SHEET NO. 17
ILLINOIS FED. AID PROJECT			CONTRACT NO. 60V58	