

**ELEVATION AT SOUTH ABUTMENT**

**SOUTH ABUTMENT TYPE I ELASTOMERIC EXP. BRG.**

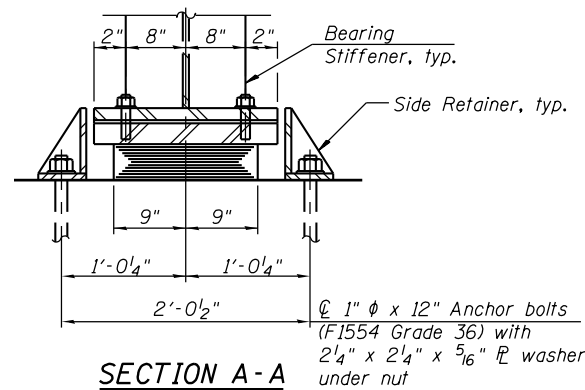

**SECTION A-A**

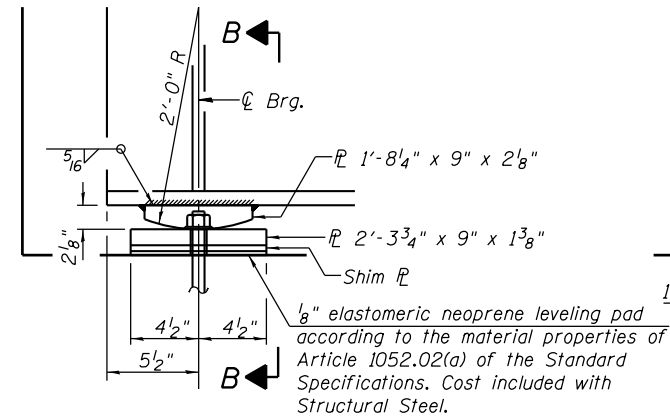

**ELEVATION AT NORTH ABUTMENT**

**NORTH ABUTMENT FIXED BEARING**

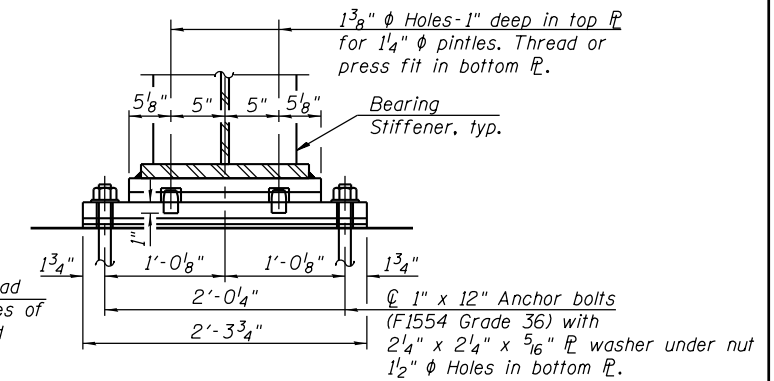

**SECTION B-B**

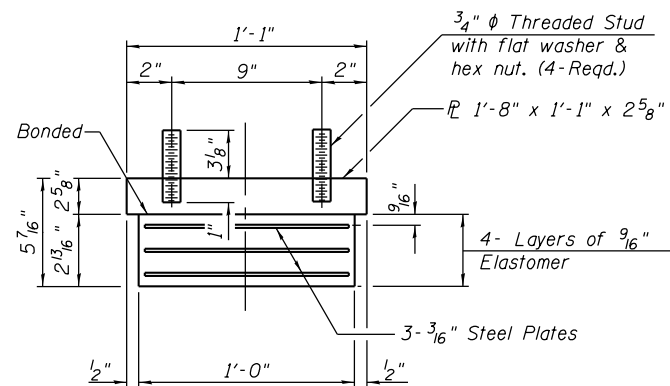

**SOUTH ABUTMENT BEARING ASSEMBLY**

Note:  
Shim plates shall not be placed under Bearing Assembly.

Notes:  
Anchor bolts shall be ASTM F1554 all-thread (or an Engineer-approved alternate material) of the grade(s) and diameter(s) specified. The corresponding specified grade of AASHTO M314 anchor bolts may be used in lieu of ASTM F1554.  
Anchor bolts of fixed bearings may be either cast in place or installed in holes drilled after the supported member is in place.  
Anchor bolts for side retainers may be cast in place or installed in holes drilled before or after members are in place.  
Drilled and set anchor bolts shall be installed according to Article 521.06 of the Standard Specifications.  
Side retainers and other steel members required for the elastomeric bearing assembly shall be included in the cost of Elastomeric Bearing Assembly, Type I.

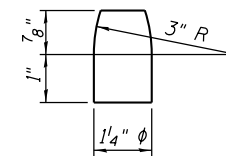

**PINTLE**

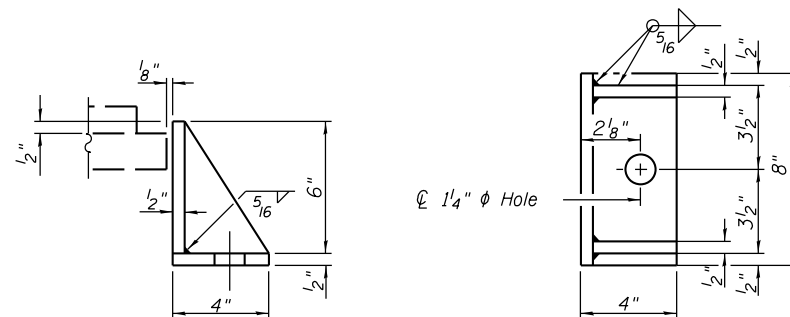

**SOUTH ABUTMENT SIDE RETAINER**

Equivalent rolled angle with stiffeners will be allowed in lieu of welded plates.

**BILL OF MATERIAL**

Item	Unit	Total
Elastomeric Bearing Assembly Type I	Each	16
Anchor Bolts, 1"	Each	64

FILE NAME = S:\JOL\6300-6399\6346\025\Micro\Sha\Structural\Plans\0980015-64C17-020-BEAR.dgn