

# TYPICAL BENCHING ON EXISTING EMBANKMENT

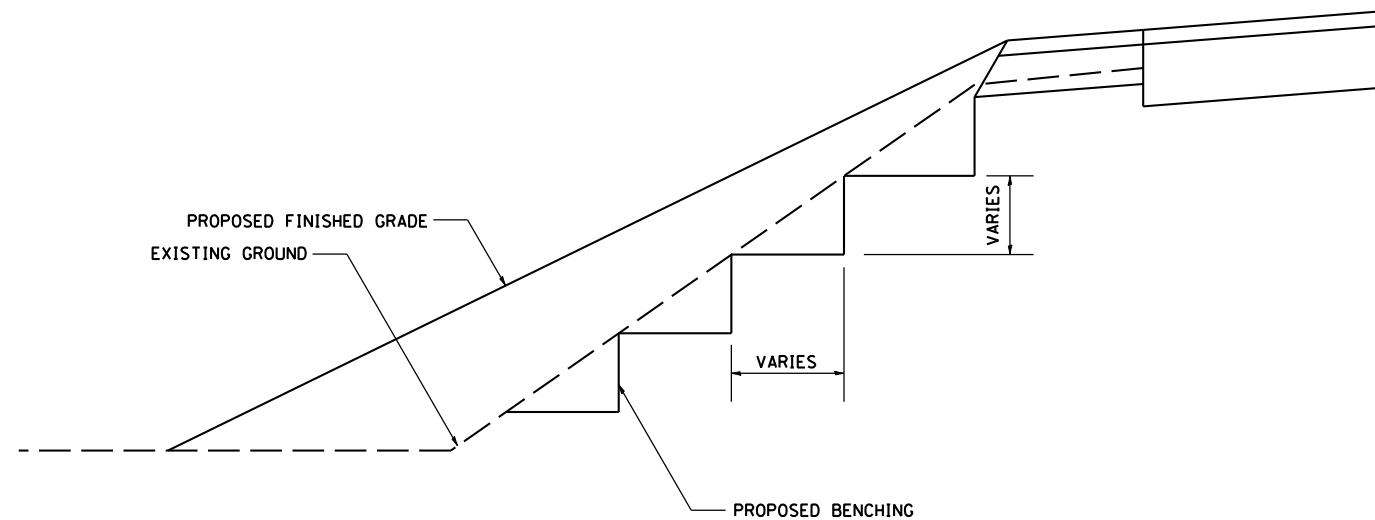

REVISED - 2-22-06

**TYPICAL BENCHING ON EXISTING EMBANKMENT 50.4**

# WITNESS MARKER FOR PERMANENT SURVEY MARKERS, TYPE II

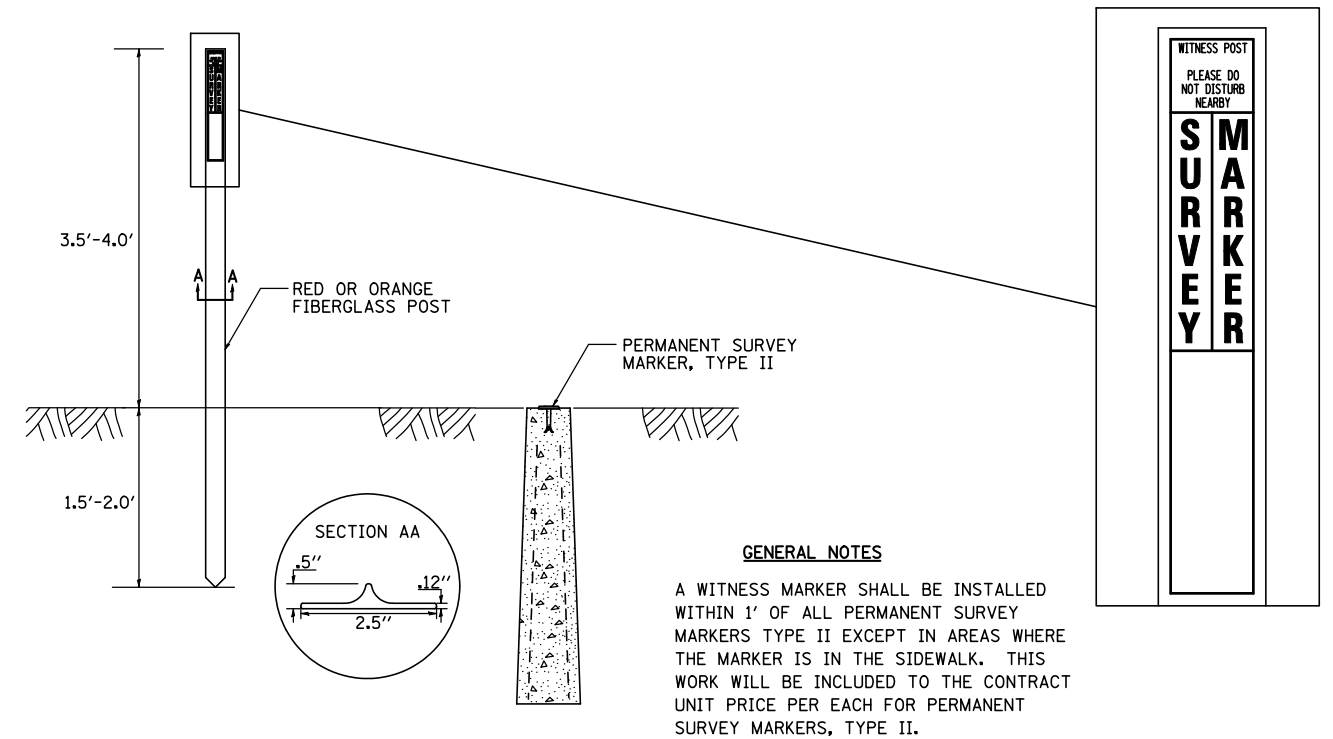

# PERMANENT SURVEY MARKERS, TYPE II

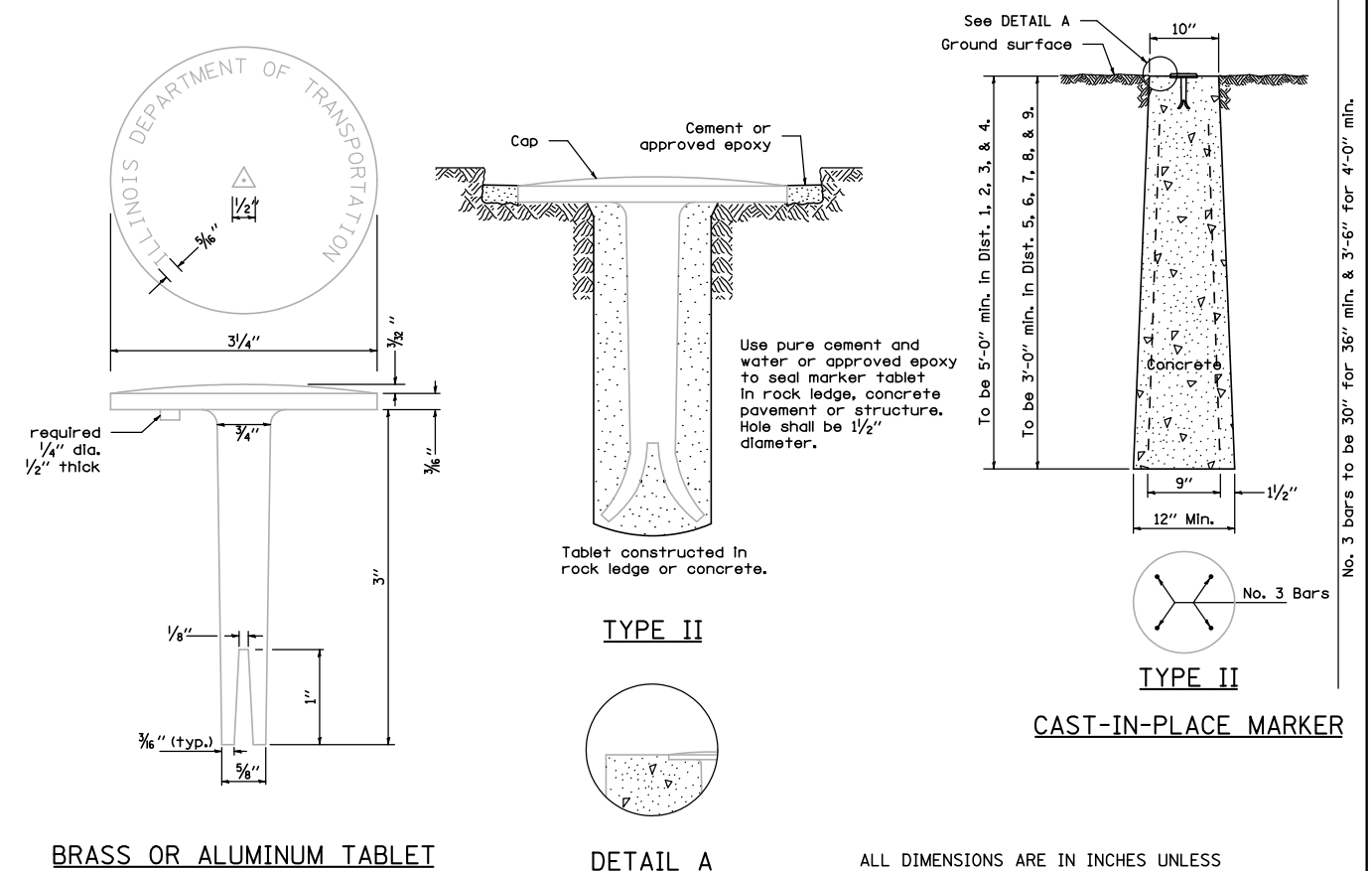

**BRASS OR ALUMINUM TABLET**

**DETAIL A**

**TYPE II CAST-IN-PLACE MARKER**

ALL DIMENSIONS ARE IN INCHES UNLESS OTHERWISE NOTED.

REVISED - 10-14-11	<b>REGION 2 / DISTRICT 2 STANDARD</b>			F.A.P. RTE.	SECTION	COUNTY	TOTAL SHEETS	SHEET NO.	
REVISED -				646	101 BR-3	WHITESIDE	113	94	
REVISED -				SCALE: 2.0000' / IN.		SHEET NO. OF SHEETS STA. TO STA.		CONTRACT NO. 64C17	
REVISED -				FED. ROAD DIST. NO. 2 ILLINOIS FED. AID PROJECT					

PLOT DATE = 10/12/2012