

DETAIL OF MEDIAN CROSSOVER TO BE RECONSTRUCTED

STATION 732+05 & 805+43

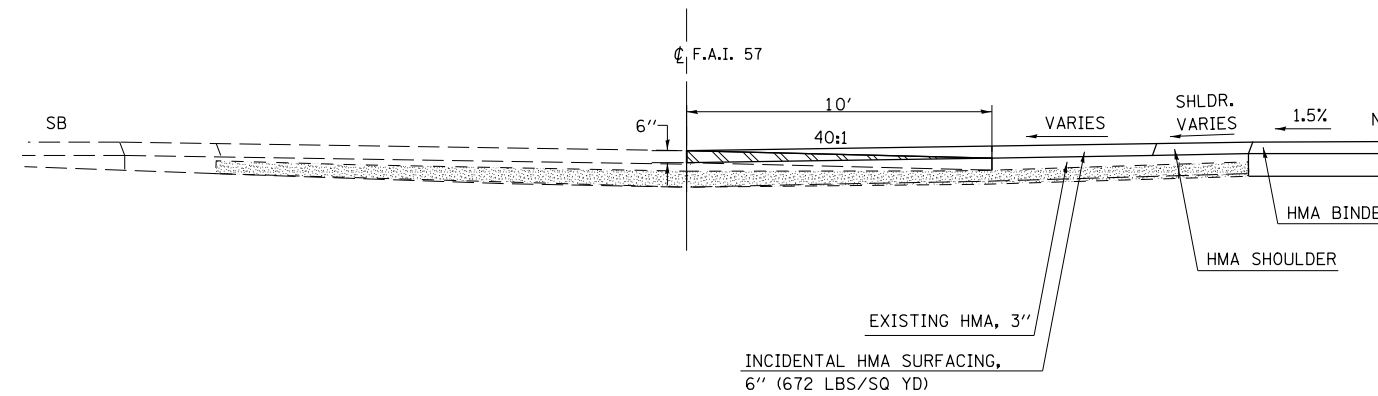
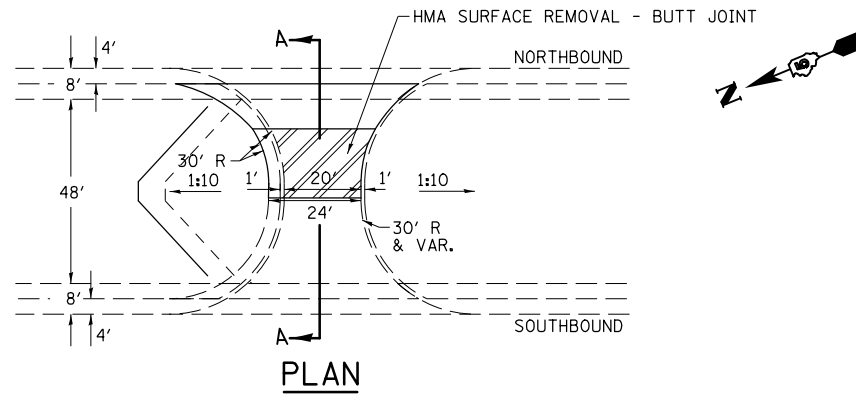
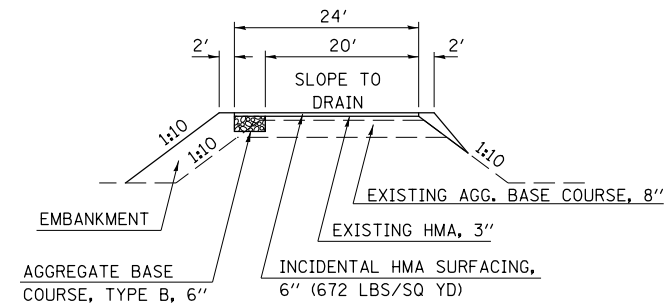

NOTES

1. OMIT RUMBLE STRIPS ON SHOULDERS THROUGHOUT MEDIAN CROSSOVER.
2. THE COST OF REMOVAL OF EXISTING AGGREGATE SHOULDERS IS INCLUDED IN THE COST PER SQ. YD. OF PROPOSED AGGREGATE BASE COURSE TYPE B, 6".
3. EXACT LOCATIONS OF BUTT JOINTS ON THE CROSSOVERS SHALL BE DETERMINED IN THE FIELD BY THE ENGINEER.

FILE NAME =	USER NAME = keysrb	DESIGNED -	REVISED -	STATE OF ILLINOIS DEPARTMENT OF TRANSPORTATION	MEDIAN CROSSOVER DETAILS			F.A.I. RTE.	SECTION	COUNTY	TOTAL SHEETS	SHEET NO.	
et:\pwork\pwork\keysrb\0158448\05707	6-sht-details.dgn	DRAWN -	REVISED -		SCALE:	SHEET NO. 1 OF 1 SHEETS	STA.	TO STA.	57	(10-34, 10-35)RS-2(NB)	CHAMPAIGN	53	37
	PLOT SCALE = 40.0000' / in.	CHECKED -	REVISED -					CONTRACT NO. 70716			ILLINOIS FED. AID PROJECT		
	PLOT DATE = 11/13/2012	DATE -	REVISED -										