

NOTE:
PROPOSED SAWCUTS ARE TO BE INCLUDED IN THE COSTS FOR "HMA SURFACE REMOVAL, 2 1/4".

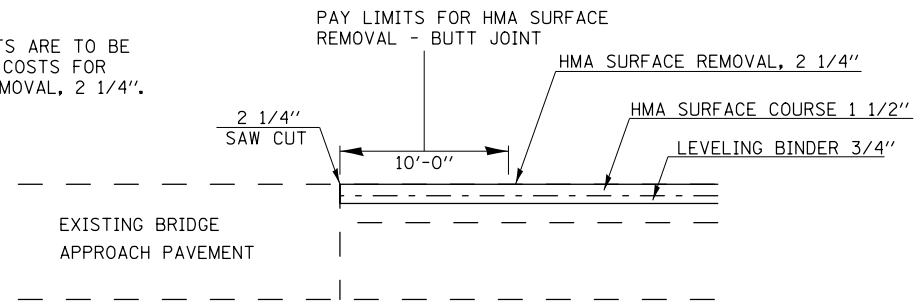

BUTT JOINT DETAIL #1

- STA 382+14.24 - STA 382+24.24
- STA 384+04.12 - STA 384+14.12
- STA 452+95.16 - STA 453+05.16
- STA 453+51.28 - STA 453+61.28
- STA 489+85.07 - STA 489+95.07
- STA 492+05.00 - STA 492+15.00
- STA 572+21.94 - STA 572+31.94
- STA 575+21.97 - STA 575+31.97

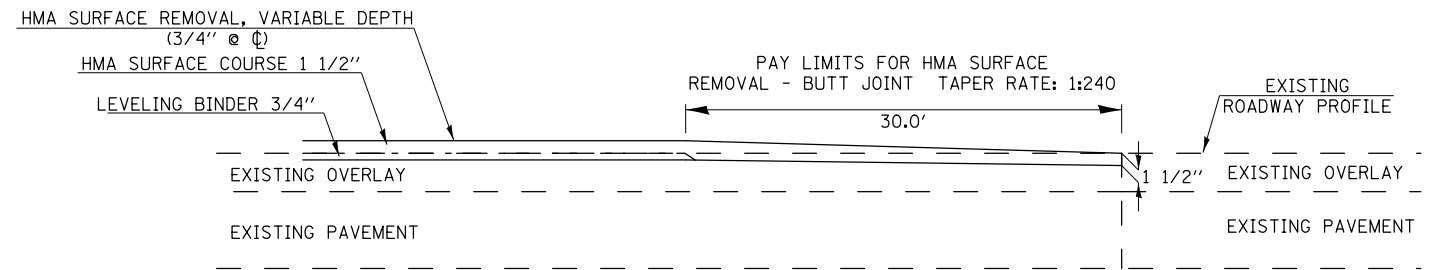

BUTT JOINT DETAIL #2

- STA 325+19.08 - STA 325+49.08
- STA 730+98.89 - STA 731+28.89

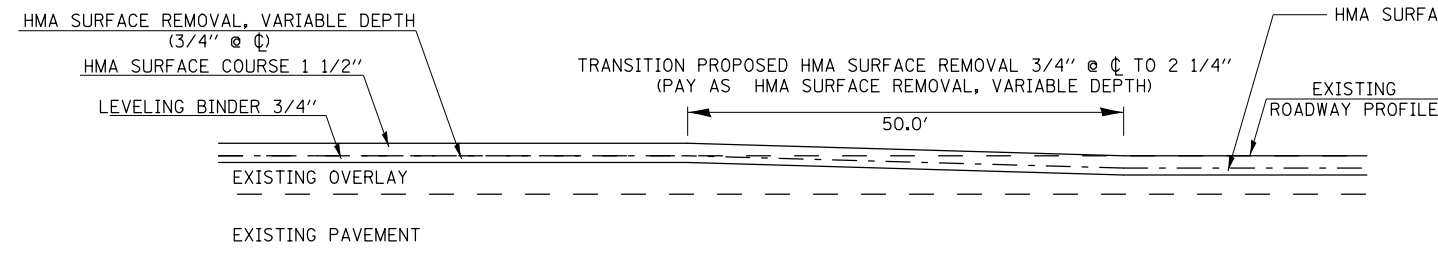

TRANSITION RAMP DETAIL #1

- STA 379+50.00 - STA 380+00.00
- STA 451+50.00 - STA 452+00.00
- STA 487+50.00 - STA 488+00.00
- STA 567+00.00 - STA 567+50.00
- STA 620+78.30 - STA 621+28.30

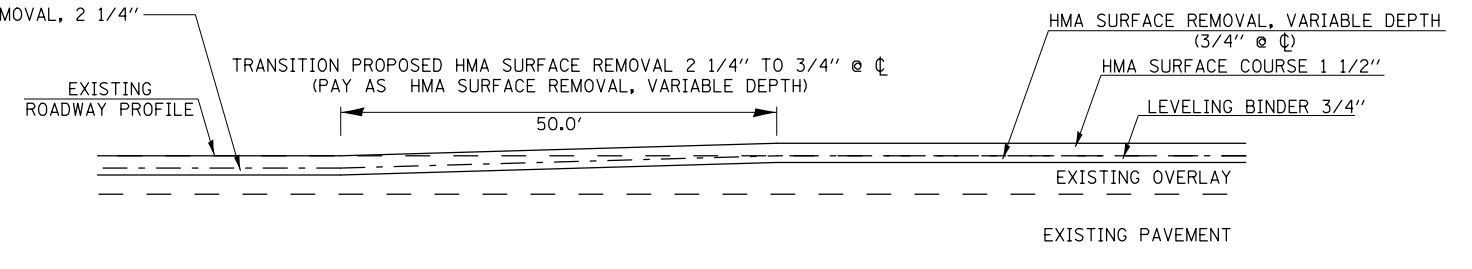

TRANSITION RAMP DETAIL #2

- STA 386+00.00 - STA 386+50.00
- STA 454+50.00 - STA 455+00.00
- STA 494+00.00 - STA 494+50.00
- STA 577+00.00 - STA 577+50.00
- STA 681+66.92 - STA 682+16.92