

Notes:
 See sheet 10 of 26 for Detail A.
 Approach slab concrete shall be paid for as Concrete Superstructure.
 Approach footing concrete shall be paid for as Concrete Structures.
 Reinforcement shall be paid for as Reinforcement Bars, Epoxy Coated.
 The approach footing maximum applied service bearing pressure (Qmax) = 2.0 ksf.
 For bar splicer details, see sheet 26 of 26.
 Cost of excavation for approach footing included with Concrete Structures.
 For Porous Granular Embankment (Special) and drainage treatment details, see sheet 2 of 26.

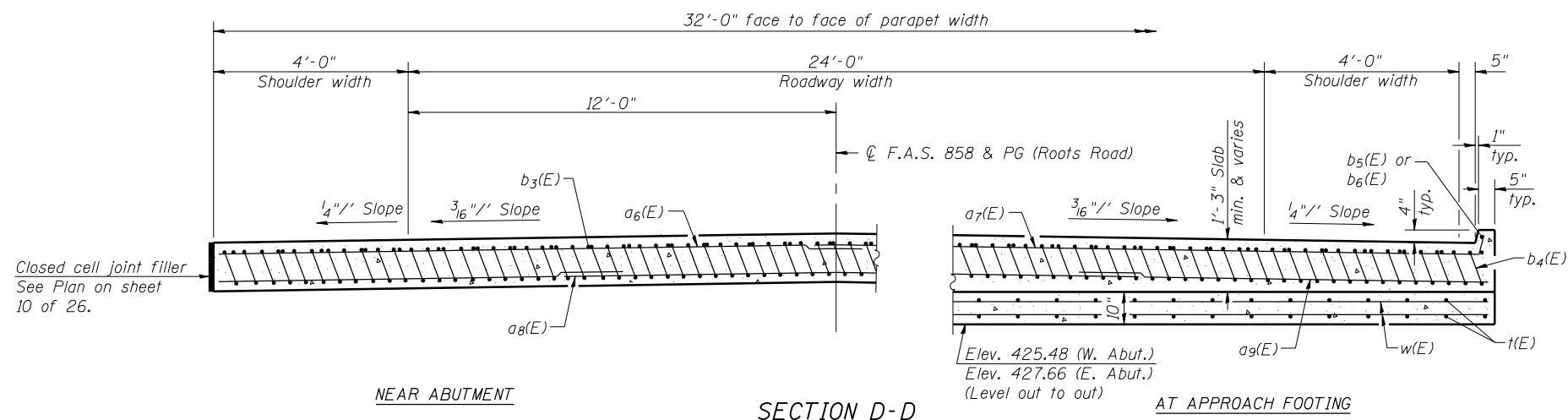

* Tilt #9 b4(E) bars as required to maintain clearance.
 ** Cost included with Concrete Superstructure.

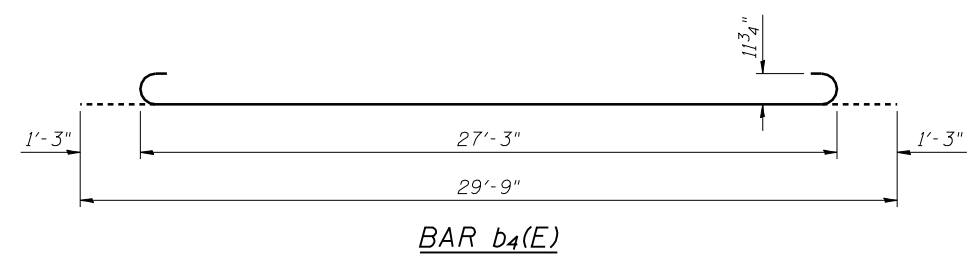
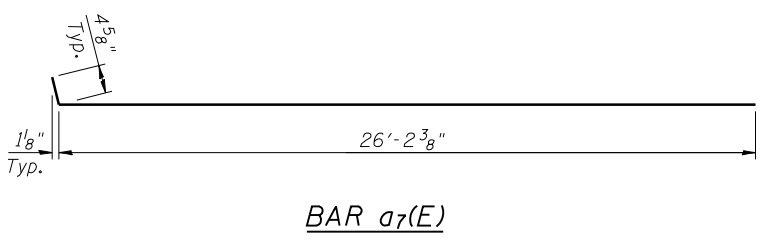
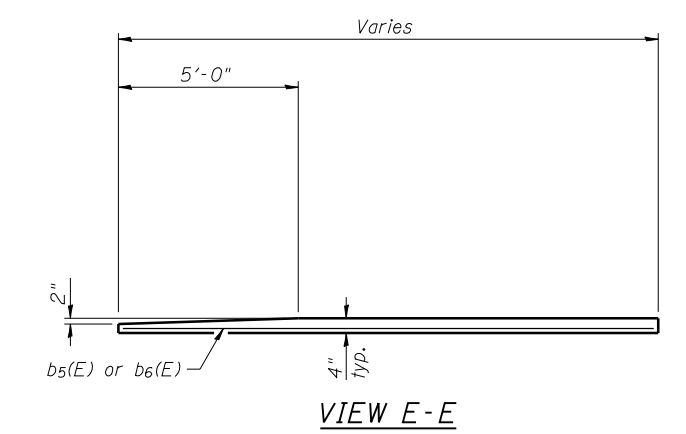

**TWO APPROACHES
 BILL OF MATERIAL**

Bar	No.	Size	Length	Shape
a6(E)	52	#4	25'-3"	—
a7(E)	48	#4	26'-7"	—
a8(E)	138	#5	17'-10"	—
a9(E)	138	#5	18'-8"	—
b3(E)	54	#4	29'-8"	—
b4(E)	154	#9	29'-9"	—
b5(E)	2	#4	17'-3"	—
b6(E)	2	#4	15'-1"	—
t(E)	140	#4	14'-11"	—
w(E)	160	#5	26'-9"	—
Concrete Superstructure			Cu. Yd.	101.6
Concrete Structures			Cu. Yd.	31.8
Reinforcement Bars, Epoxy Coated			Pound	29,540