

PAVEMENT UNDERCUT DETAIL

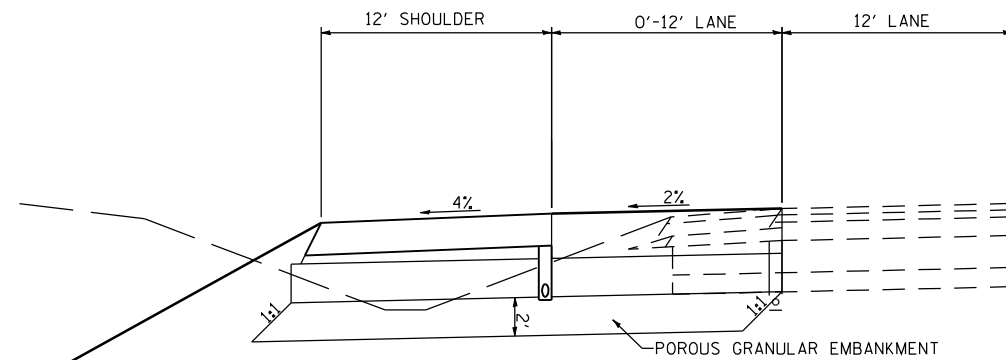

NOTE
FOR PAVEMENT SECTION DETAILS SEE TYPICAL SECTIONS

LEGEND

PROPOSED

- ⑫ STEEL PLATE BEAM GUARDRAIL, TYPE A, 6' POSTS
- ⑬ HOT-MIX ASPHALT STABILIZATION 6" AT STEEL PLATE BEAM GUARDRAIL

NOTES

1. EXISTING PIPE UNDERDRAINS, OUTLET PIPES, AND HEADWALLS TO BE REMOVED. COST INCLUDED IN EARTH EXCAVATION.

PAVEMENT STRUCTURE DESIGN

STRUCTURAL DESIGN TRAFFIC;	YEAR 2020
PV = 31,950	SU = 2820 MU = 9450
ROAD/STREET CLASSIFICATION	CLASS 1
PERCENT OF STRUCTURAL DESIGN TRAFFIC IN DESIGN LANE;	
P = 20	S = 40 M = 40
TRAFFIC FACTOR	ACTUAL TF = 39.49 AC TYPE = SBS
	MANUAL TF = NA
PG GRADE;	BINDER = 76-22 SURFACE = 76-22

TYPICAL SECTIONS - GUARDRAIL AND TRAFFIC BARRIER TERMINALS ADJACENT TO SHOULDER

NORTHBOUND:

- STA. 165+77.20 - STA. 169+22.84 (OUTSIDE)
- STA. 175+91.23 - STA. 178+92.79 (OUTSIDE)
- STA. 180+18.45 - STA. 182+87.19 (INSIDE)
- STA. 180+48.42 - STA. 183+90.57 (OUTSIDE)
- STA. 226+74.41 - STA. 228+01.58 (INSIDE)
- STA. 227+23.32 - STA. 228+50.49 (OUTSIDE)
- STA. 228+70.74 - STA. 231+01.98 (INSIDE)
- STA. 229+19.65 - STA. 231+50.89 (OUTSIDE)
- STA. 254+82.49 - STA. 257+44.99 (INSIDE)
- STA. 255+00.53 - STA. 258+33.67 (OUTSIDE)
- STA. 346+77.08 - STA. 350+56.11 (INSIDE)
- STA. 363+24.78 - STA. 366+70.43 (OUTSIDE)
- STA. 363+37.30 - STA. 365+74.80 (INSIDE)

SOUTHBOUND:

- STA. 224+99.11 - STA. 227+30.35 (OUTSIDE)
- STA. 225+48.02 - STA. 227+79.26 (INSIDE)
- STA. 227+99.51 - STA. 229+26.68 (OUTSIDE)
- STA. 228+48.42 - STA. 229+75.59 (INSIDE)
- STA. 252+69.93 - STA. 255+32.43 (INSIDE)
- STA. 344+68.30 - STA. 348+47.10 (INSIDE)
- STA. 361+40.81 - STA. 363+78.30 (INSIDE)
- STA. 373+30.64 - STA. 375+30.63 (INSIDE)
- STA. 401+54.37 - STA. 403+66.87 (INSIDE)

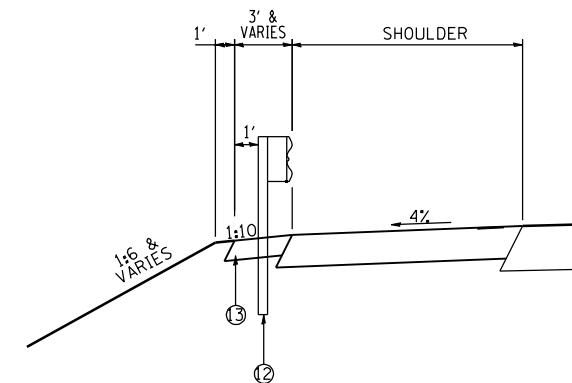

EFK Moen, LLC
Civil Engineering Design

FILE NAME =	USER NAME = \$USER*	DESIGNED - JRD	REVISED -	STATE OF ILLINOIS DEPARTMENT OF TRANSPORTATION	TYPICAL SECTION SHEETS	F.A.I. RTE.	SECTION	COUNTY	TOTAL SHEETS	SHEET NO.	
\$FILEL\$		DRAWN - MSK	REVISED -			57	(X1-6-2,X1-5,(X1-4-1BR-1)R-1	WILLIAMSON	202	12	
	PLOT SCALE = \$SCALE*	CHECKED - SLD	REVISED -			CONTRACT NO. 78334					
	PLOT DATE = \$DATE*	DATE - 02/01/2013	REVISED -			ILLINOIS FED. AID PROJECT					
				SCALE: N. T. S. SHEET NO. 4 OF 4 SHEETS STA. TO STA.							