

ROUTE	SECTION	COUNTY	TOTAL SHEETS	SHEET NO.
TR 308	06-04122-00-BR	FRANKLIN	12	11
PROJECT NO. BROS-058(63)			CONTRACT NO. 99307	

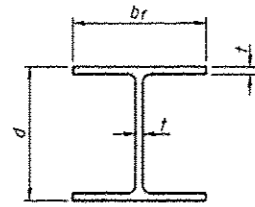

STEEL PILE TABLE

Designation	Depth d	Flange width br	Web and Flange thickness t	Encasement diameter A	Encasement Quantity/Ft. C.Y.
HP 14x117	14 1/4"	14 7/8"	1 3/16"	30"	0.173
x102	14"	14 3/4"	1 1/16"	30"	0.174
x89	13 7/8"	14 3/4"	9/8"	30"	0.175
x73	13 5/8"	14 5/8"	1/2"	30"	0.176
HP 12x84	12 1/4"	12 1/4"	1 1/16"	24"	0.110
x74	12 1/8"	12 1/4"	5/8"	24"	0.111
x63	12"	12 1/8"	1/2"	24"	0.112
x53	11 3/4"	12"	7/16"	24"	0.112
HP 10x57	10"	10 1/4"	9/16"	24"	0.112
x42	9 3/4"	10 1/8"	7/16"	24"	0.113
HP 8x36	8"	8 1/8"	7/16"	18"	0.063

Note: The steel H-piles shall be according to AASHTO M270 Grade 50.

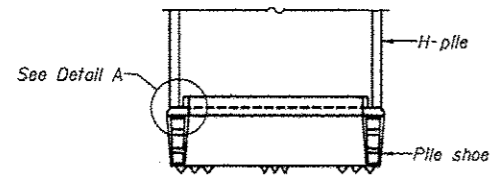

ELEVATION

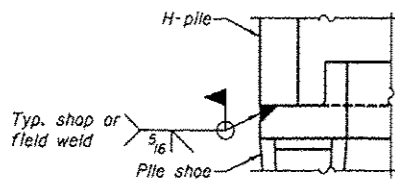

DETAIL A

H-PILE SHOE ATTACHMENT

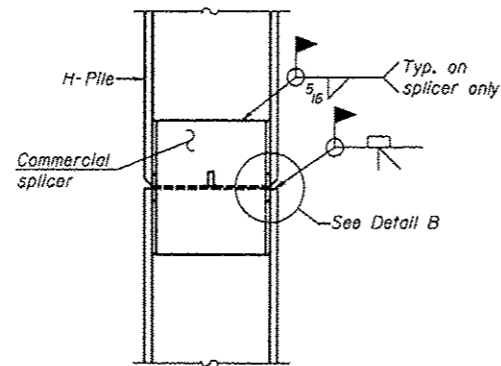

ELEVATION

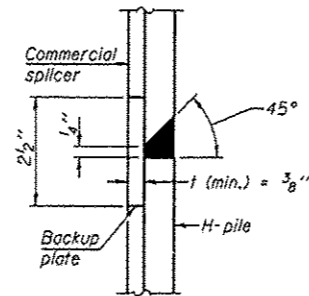

DETAIL "B"

WELDED COMMERCIAL SPLICE

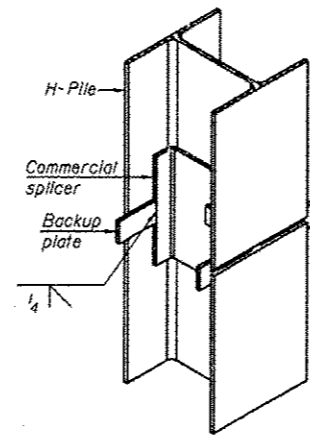

ISOMETRIC VIEW

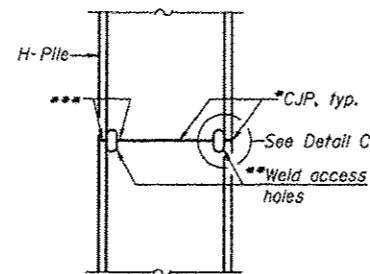

ELEVATION

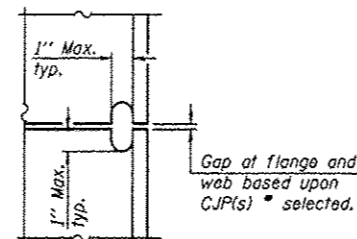

DETAIL C

COMPLETE PENETRATION WELD SPLICE

*Use joint conforming to Figure 3.4 in AWS D1.1, Structure Welding Code - Steel.

**Preparation per Fig. 5.2 in AWS D1.1, Structure Welding Code - Steel.

***Interrupt welds 1/4" from end of each pile.

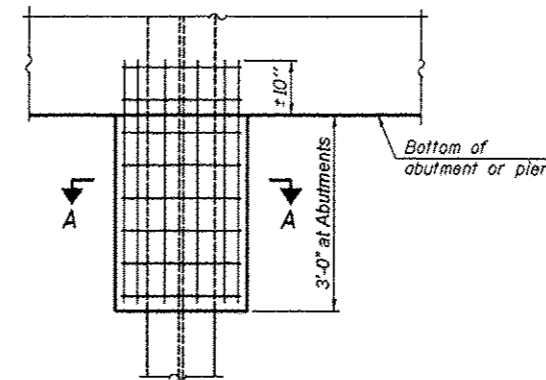

ELEVATION

PILE ENCASEMENT

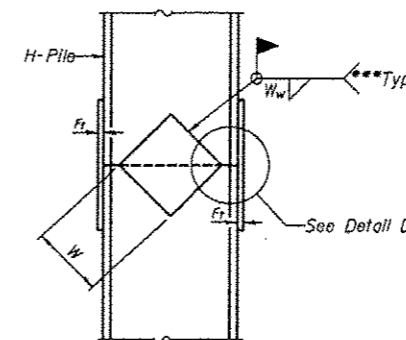

ELEVATION

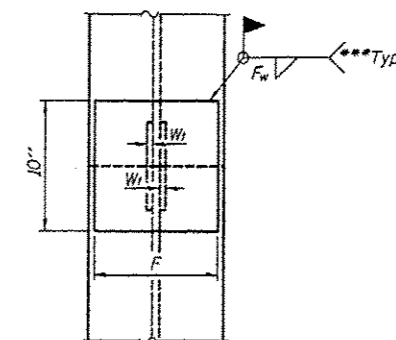

END VIEW

WELDED PLATE FIELD SPLICE

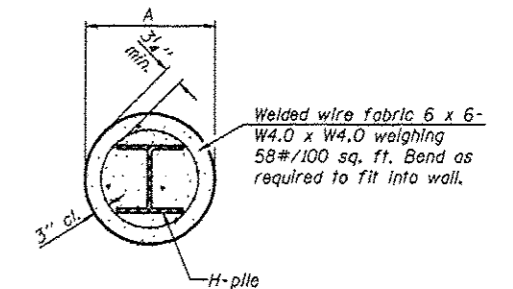

SECTION A-A

Note: Forms for encasement may be omitted when soil conditions permit.

Designation	F	Ft	Fw	W	Wt	Ww
HP 14x117	12 1/2"	1"	7/8"	7 3/4"	5 1/2"	1/2"
x102	12 1/2"	7/8"	3/4"	7 3/4"	5 1/2"	1/2"
x89	12 1/2"	3/4"	1/2"	7 3/4"	5 1/2"	1/2"
x73	12 1/2"	5/8"	9/16"	7 3/4"	5 1/2"	1/2"
HP 12x84	10"	7/8"	1/2"	6 1/2"	5 1/2"	1/2"
x74	10"	7/8"	1/2"	6 1/2"	5 1/2"	1/2"
x63	10"	5/8"	1/2"	6 1/2"	1/2"	3/8"
x53	10"	5/8"	1/2"	6 1/2"	1/2"	3/8"
HP 10x57	8"	3/4"	9/16"	5 1/4"	1/2"	3/8"
x42	8"	5/8"	9/16"	5 1/4"	1/2"	3/8"
HP 8x36	7"	5/8"	7/16"	4 1/4"	1/2"	3/8"

PILING DETAILS
TOWNSHIP ROUTE 308 (HANAGAN ROAD)
EWING CREEK
SECTION 06-04122-00-BR
FRANKLIN COUNTY
STRUCTURE NO. 028-3407