

UNDERDRAIN CLEANOUT

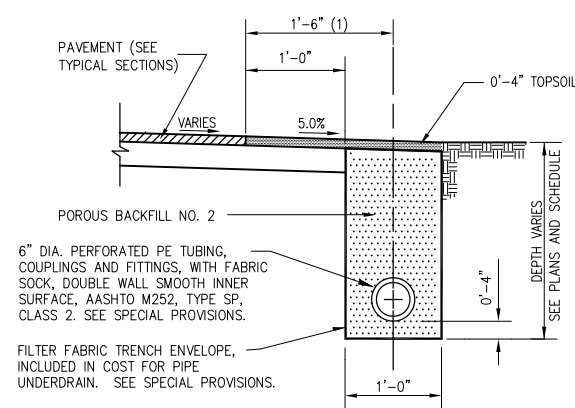

UNDERDRAIN ALONG PAVEMENT EDGE

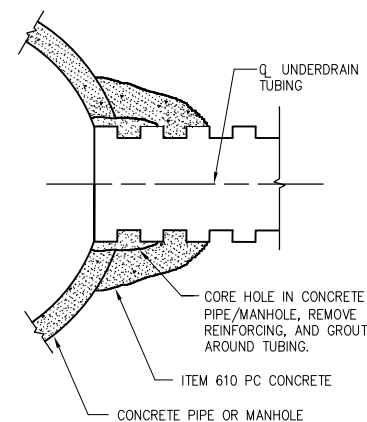

STORM SEWER CONCRETE COLLAR AND GROUT CONNECTION

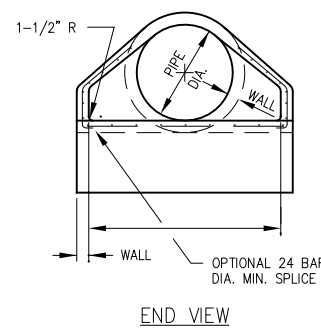

END VIEW

PIPE DIA.	WALL	A	B	C	D	E	R	SLOPE
12"	2"	4"	2'-0"	4'-0 7/8"	6'-0 7/8"	2'-0"	9"	3:1

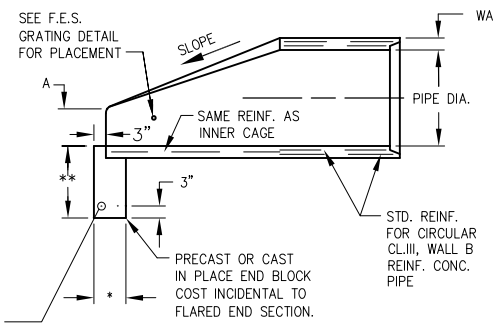

SECTION A-A

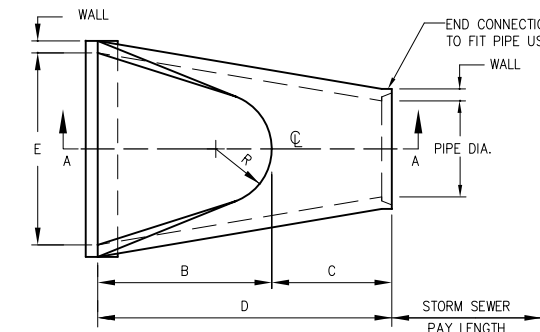

TOP VIEW

PRECAST CONCRETE FLARED END SECTION (IDOT STANDARD 542301-MODIFIED)

REVISION
DATE

MT. VERNON AIRPORT

 MT. VERNON, ILLINOIS

IL. PROJ.: MW-4197 SBG PROJ.: 3-17-0074-B27

Hanson Project No. 12A0044D
 Filename 21-C-801-DRNDET.DWG
 Scale N/A
 Date 3/1/13

LAYOUT	LDH	12/14/12
DRAWN	LDH	12/14/12
REVIEWED	BSS	2/21/13

HANSON
 Hanson Professional Services Inc. 2013
 1525 South Main Street
 Springfield, Illinois 62703-2886

CONSTRUCT APRON AND TAXIWAY IN SOUTH FRONTAL AREA

UNDERDRAIN AND DRAINAGE DETAILS