

DETAIL A

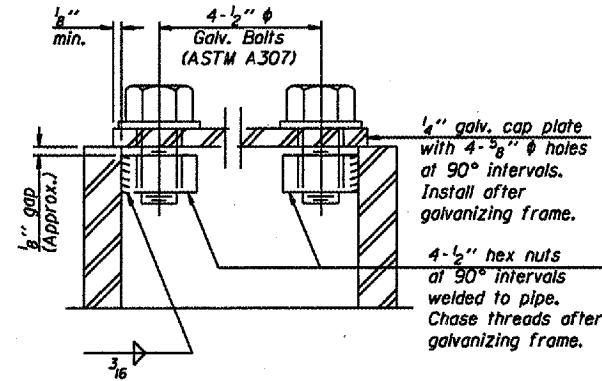

SECTION A-A

As an alternate to bolts, may use galvanized drive-fit caps installed after galvanizing frame.

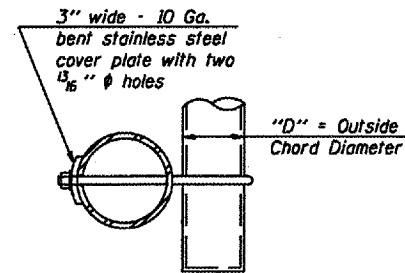

SECTION B-B

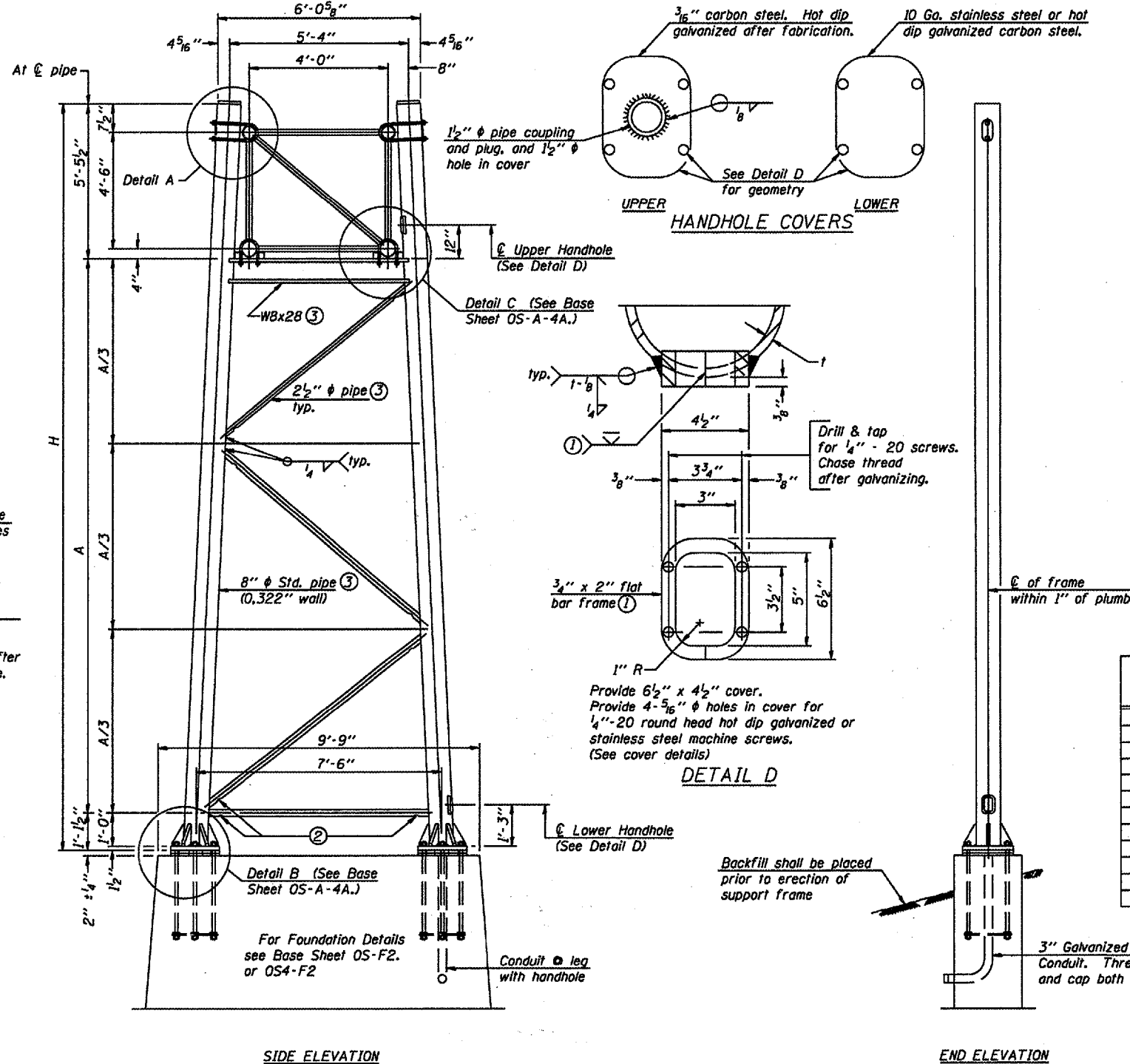

SIDE ELEVATION

END ELEVATION

8" ϕ PIPE TRUSS SUPPORT FRAME

Support Design Loads: See Base Sheet OS-A-1 for design and loading criteria.
Load combinations checked include deadload plus:
a) 100% wind normal to sign, 20% parallel to sign
b) 60% wind normal to sign, 30% parallel to sign

- ① In lieu of fabricated handhole frame as shown, may cut from 2" plate (rolling direction vertical). All cut faces to be ground to ANSI Roughness of 500 μ in or less.
- ② Galvanizing vent holes of adequate size shall be provided on underside at each end of bracing pipes. Alternately, holes may be provided in wall of pipe column. All vent holes shall be drilled and de-burred, typ.
- ③ Steel pipe, plate, carbon steel handhole covers and rolled sections shall be hot dip galvanized after fabrication. Painting is not permitted. See Base Sheet OS-A-1.
- ④ See General Notes for fasteners.
- ⑤ Dimensions shown are based on selection criteria in the Sign Structures Manual. Nonstandard applications must have dimensions verified or amended as appropriate.
- ⑥ "H" based on 15'-0" or actual sign height, whichever is greater.

Structure Number	Station	Support		H ⑥	A
		Left	Right		
5S0921074R213.40	1882 + 50	X	X	26'-6"	19' - 11"

DESIGNED -	20
CHECKED -	EXAMINED
DRAWN -	PASSED
CHECKED -	ENGINEER OF BRIDGES AND STRUCTURES

NUMBER	REVISION	DATE

OS-A-4 7/01/2006

OVERHEAD SIGN STRUCTURES
SUPPORT FRAME FOR TYPE I-A ALUMINUM TRUSS

District 5
Overhead Sign
Structure Replacement