

F.A.P. RTE.	SECTION	COUNTY	TOTAL SHEETS	SHEET NO.
100	104 RS-8	MCHENRY	22	5
STA.		TO STA.		
FED. ROAD DIST. NO.	ILLINOIS	FED. AID PROJECT		

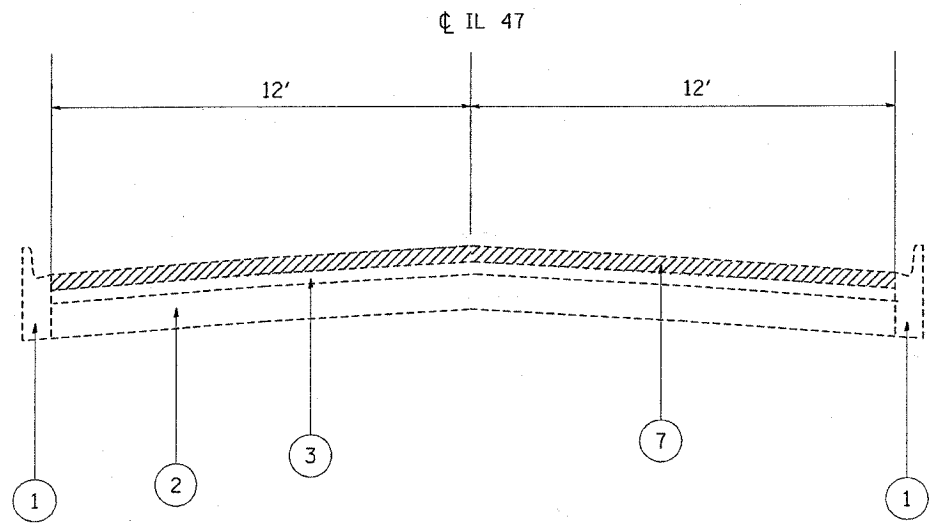

EXISTING TYPICAL SECTION  
STA. 4+90 TO STA. 15+00

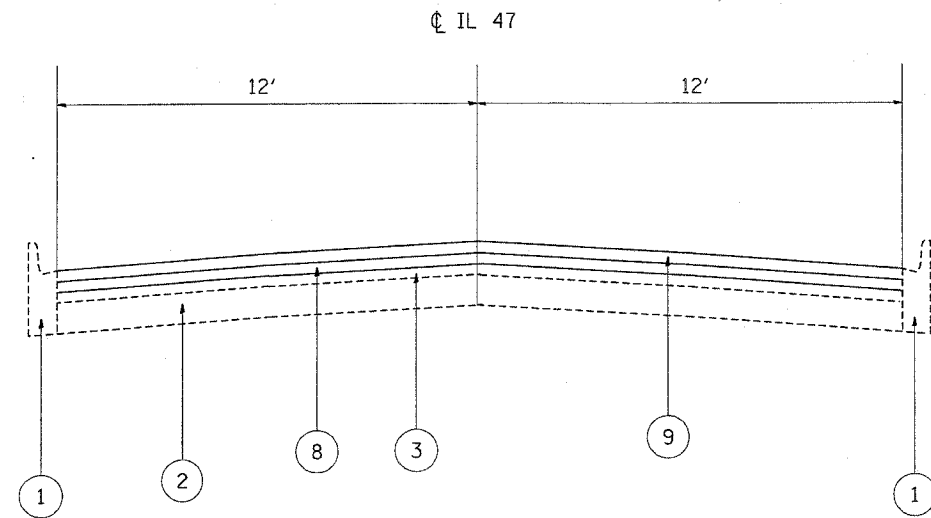

PROPOSED TYPICAL SECTION  
STA. 4+90 TO STA. 15+00

LEGEND

- 1 EXISTING B6.24 CURB & GUTTER
- 2 EXISTING P.C.C. BASE COURSE 9" ±
- 3 EXISTING HOT MIX ASPHALT OVERLAY 8" ±
- 4 EXISTING GUARDRAIL
- 5 EXISTING AGGREGATE WEDGE SHOULDER TYPE B
- 6 EXISTING HOT-MIX ASPHALT SHOULDERS
- 7 PROPOSED HOT MIX ASPHALT SURFACE REMOVAL 2 1/4"
- 8 PROPOSED POLYMERIZED LEVELING BINDER (MACHINE METHOD), IL-4.75, N50 (3/4")
- 9 PROPOSED HOT MIX ASPHALT SURFACE COURSE, MIX "D", N50 (1 1/2")
- 10 PROPOSED GRADING AND SHAPING SHOULDERS
- 11 PROPOSED AGGREGATE WEDGE SHOULDER, TYPE B

GUARDRAIL VARIES FROM LOCATION TO LOCATION WITHIN STA. 35+00 TO STA. 73+00

REVISIONS	
NAME	DATE

ILLINOIS DEPARTMENT OF TRANSPORTATION

EXISTING AND PROPOSED TYPICAL SECTIONS

SCALE: VERT. / HORIZ.  
DATE

DRAWN BY / CHECKED BY