

**1**  
STIFFENER INTERSECTION MODIFICATION DETAIL  
S52

Procedure - Detail 1/S52 and 2/S52:

1. Core 4" diameter holes positioned close to corner junction through 3/8" thick horizontal stiffener.
2. Remove material between core and intersection junction by grinding with carbide tools and a die grinder as shown in Detail 2/S52. Web plate surface shall have a roughness average (Ra) 250 or less.
3. Remove all burrs from cut edge and check for irregularities. Cored surface shall have an Ra equal to 500 or less.
4. After burr removal the modification shall be inspected using magnetic particle (MT) methods. Notify Engineer if a crack is detected (Cost included with stiffener intersection modification).
5. Obtain approval of Engineer.
6. Clean and paint steel surfaces adjacent to the repair in accordance with the Special Provisions.

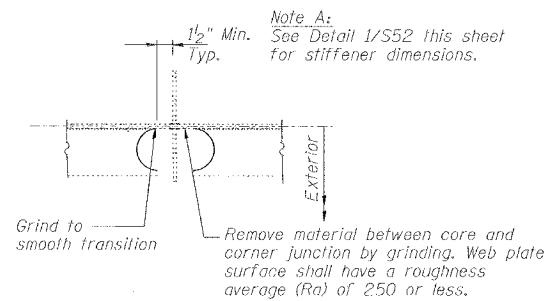

**2**  
STIFFENER INTERSECTION MODIFICATION DETAIL  
S52

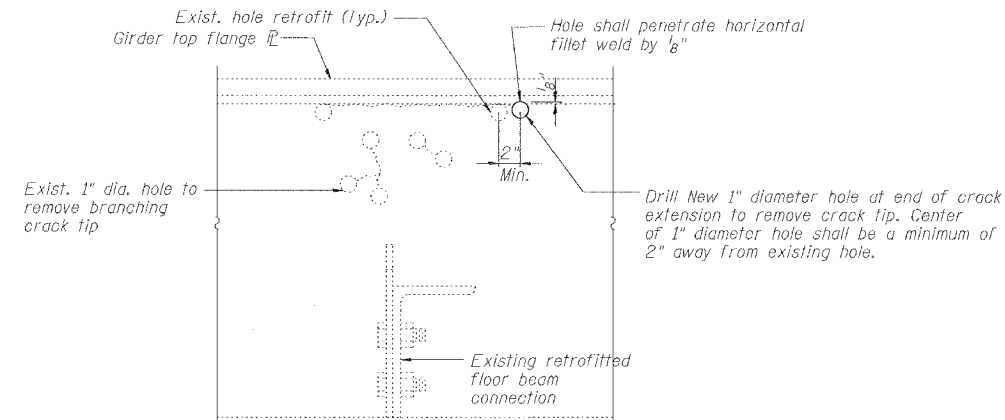

**3**  
CRACK EXTENSION RETROFIT AT FIRST INTERIOR FLOOR BEAMS  
S52

Procedure - Detail 3/S52:

1. Inspect girder web plate in region of existing retrofits to determine location of crack extension at locations directed by the Engineer, and crack tip using magnetic particle inspection (MT) methods (Cost included with crack extension retrofit at first interior floor beams).
2. Drill 1" diameter hole at end of crack extension to remove crack tip. Center of 1" diameter hole shall be positioned in accordance with Detail 3/S52.
3. Cored surfaces shall have a Roughness Average (Ra) of 500 or less.
4. Re-inspect area using MT methods to verify crack does not extend past the newly drilled holes.
5. Obtain approval of Engineer.
6. Clean and paint steel surfaces adjacent to the repair in accordance with the Special Provisions.

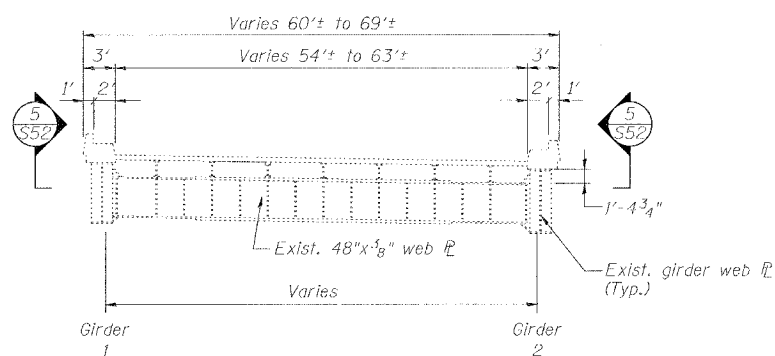

**4**  
LONG SPAN FLOOR BEAMS (> 50')  
S52

Note B: Two repair locations shown

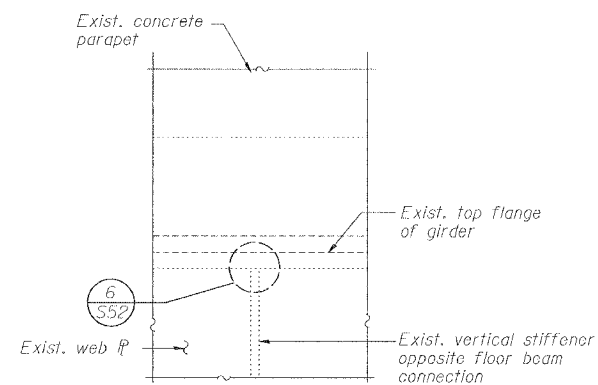

**5**  
EXTERIOR ELEVATION OF GIRDER AT FLOOR BEAM CONNECTION  
S52

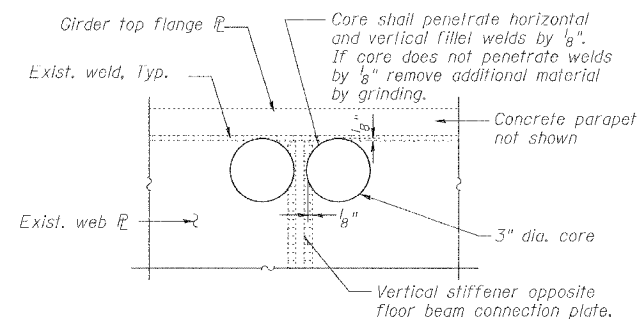

**6**  
LONG SPAN FLOOR BEAM RETROFIT  
S52

Note C: One repair location shown

Procedure Detail 6/S52:

1. Inspect using magnetic particle (MT) methods. Notify Engineer if a crack is detected (Cost included with long span floor beam retrofit).
2. Remove parapet concrete, as required, for equipment access.
3. Core 3" diameter holes through web plate adjacent to the top flange as positioned in Detail 6/S52. Core holes shall penetrate the horizontal and vertical fillet welds approximately 1/8". If core does not penetrate weld by 1/8", remove additional material by grinding. Remove all burrs from cored or ground surface. Surface shall have a roughness average (Ra) of 500 or less.
4. Obtain approval of Engineer.
5. Clean and paint steel surfaces adjacent to the repair in accordance with the Special Provisions.

REVISIONS	
NAME	DATE

**FATIGUE RETROFIT DETAILS**  
STATE OF ILLINOIS  
DEPARTMENT OF TRANSPORTATION  
REHABILITATION AND RETROFIT REPAIRS  
FAI ROUTE 70  
POPLAR STREET BRIDGE APPROACHES  
ST. CLAIR COUNTY  
STRUCTURE NO. 082-0141 (ROADWAY A)  
SCALE: N.T.S.  
DATE: 02/01/2007

DESIGNED	DDC
CHECKED	JCM
DRAWN	CLK
CHECKED	DDC