

# TYPICAL MAILBOX TURNOUT DETAIL

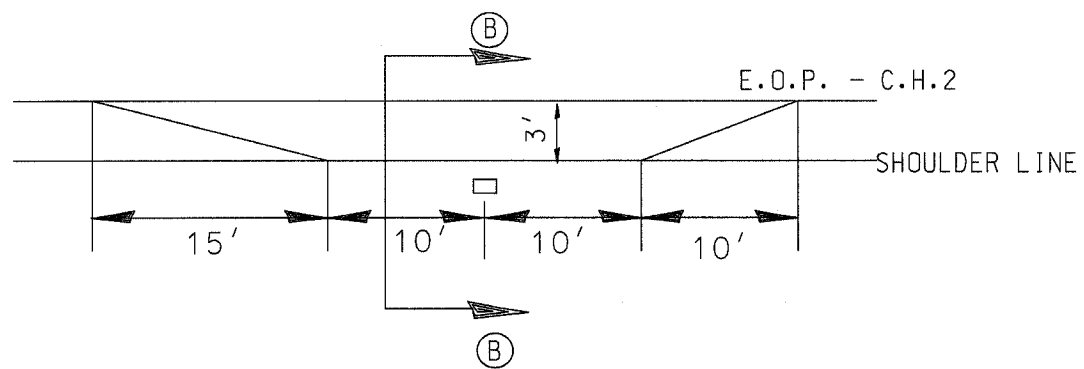

MAILBOX TURNOUTS TO BE CONSTRUCTED			
STATION	SIDE	STATION	SIDE
252+96	RT	300+62	RT
256+60	RT	306+85	RT
257+82	RT	308+62	RT
281+19	RT	324+98	RT
287+99	RT	333+43	RT
288+26	RT	346+68	RT
291+48	RT		
295+07	RT		

NOTE: MBTO'S PREVIOUSLY CONSTRUCTED SHALL RECEIVE HOT-MIX ASPHALT SURFACING ONLY.

## SECTION B-B

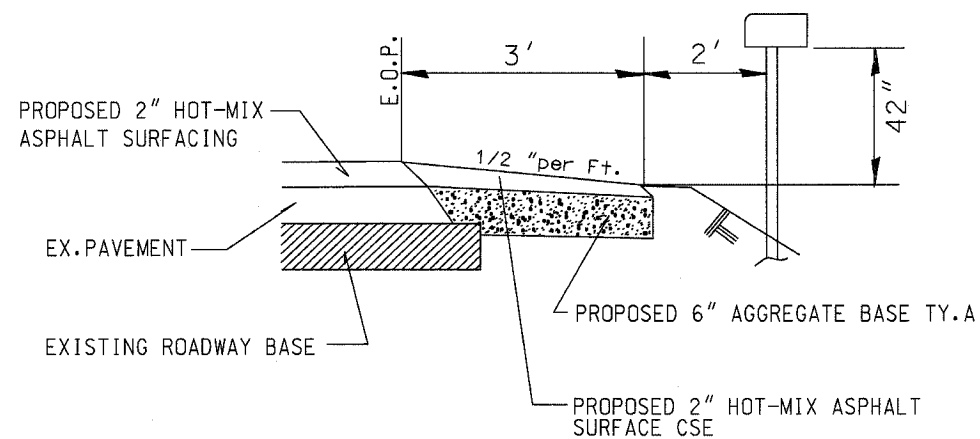

ESTIMATED QUANTITIES - 98 MAILBOX TURNOUTS		
ITEM	UNIT	QUANTITY
EARTH EXCAVATION	CU YD	35
AGG. BASE CSE. , TY. A	TON	72
BIT. MATERIALS ( PRIME COAT )	GAL	147
HOT-MIX ASPHALT SURFACE CSE. MIX C , N50	TON	196

SECTION	COUNTY	TOTAL SHEETS	SHEET NO.
04-00234-01-RS	KANKAKEE	4	4
04-00235-01-RS			
CONTRACT NO. 87323			

# TYPICAL ENTRANCE DETAIL

W :WIDTH OF APPROACH PADS IS ESTIMATED AT 20' PER ENTRANCE . THE ACTUAL CONSTRUCTED WIDTH MAY VARY AS DIRECTED BY THE ENGINEER TO FIT THE EXISTING ENTRANCES .  
FIELD ENTRANCES AND PRIVATE AGGREGATE SURFACED ENTRANCES SHALL NOT RECEIVE HOT-MIX ASPHALT SURFACING

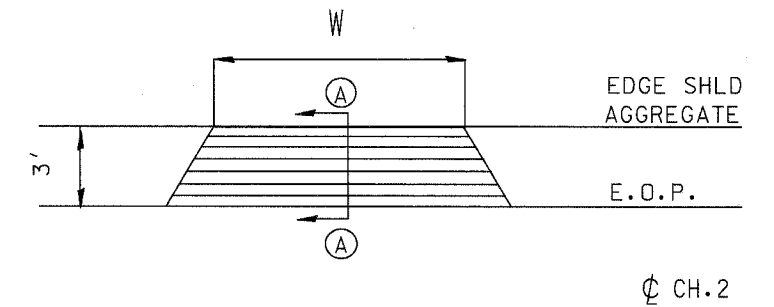

## SECTION A-A

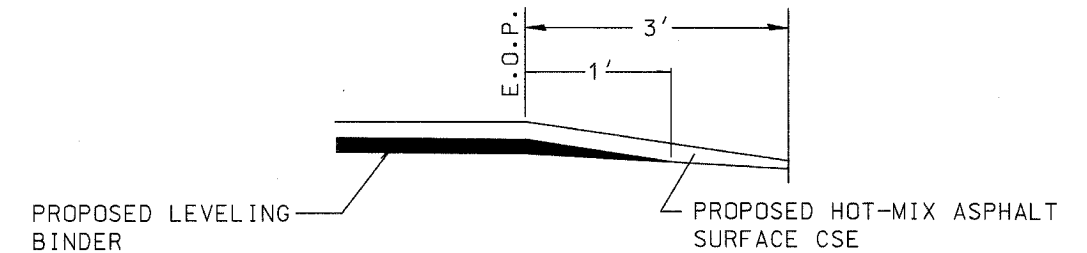

ESTIMATED QUANTITIES- 25 ENTRANCES		
ITEM	UNIT	QUANTITY
BITUMINOUS MATERIALS ( PRIME COAT )	GAL	25
LEVELING BINDER (MM) N50	TON	8
HOT-MIX ASPHALT SURFACE CSE MIX "C" N50	TON	25

## GENERAL NOTES:

1. IT SHALL BE THE CONTRACTOR'S RESPONSIBILITY TO DETERMINE THE ACTUAL LOCATION OF ALL UTILITY LOCATIONS .
2. PERMANENT PAVEMENT MARKINGS TO BE INSTALLED BY THE KANKAKEE COUNTY HIGHWAY DEPT.
3. FLAGMEN SHALL BE REQUIRED DURING PRIMING OPERATIONS.
4. "BUMP SIGNS" SHALL BE REQUIRED AT ALL TANGENT HOT-MIX ASPHALT SURFACE REMOVAL - BUTT JOINT LOCATIONS. THE COST SHALL BE CONSIDERED AS INCLUDED IN THE TRAFFIC CONTROL PAY ITEM.