

CITY OF DANVILLE
VERMILION COUNTY

PLANS FOR PROPOSED WINTER AVENUE RECONSTRUCTION

FAU ROUTE 6998 (WINTER AVENUE) AND FAU 7405 (BOWMAN AVENUE)

SECTION: 99-00209-01-PV

CONSTRUCTION JOB NO.: C-95-305-06

PROJECT NO. MHPP-2309(002)

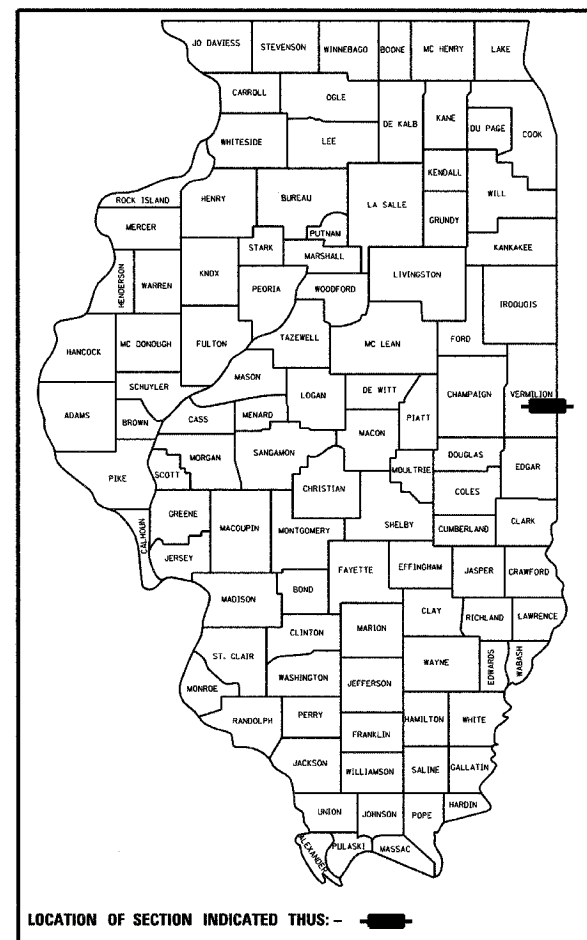

LOCATION OF SECTION INDICATED THUS: - [black rectangle] -

INDEX OF SHEETS

1	COVER SHEET
2-17	TYPICAL SECTIONS
18-19	LIST OF STANDARDS, GENERAL NOTES & COMMITMENTS
20-23	SUMMARY OF QUANTITIES
24-25	SCHEDULE OF QUANTITIES
26-31	ALIGNMENT, TIES & BENCHMARKS
32-49	PLAN SHEETS
50-59	PROFILE SHEETS
60-62	INTERSECTION DETAILS
63-67	ENTRANCE DETAILS
68-70	BICYCLE PATH DETAILS
71	CULVERT EXTENSION DETAIL
72-73	MISCELLANEOUS DETAILS
74-85	DRAINAGE PLAN SHEETS
86-92	DISTRICT 5 CAD DETAILS
93-95	TRAFFIC SIGNAL PLANS
96-101	STRIPING PLAN SHEETS
102-104	RAILROAD TRACK PLANS
105-128	RAILROAD BRIDGE PLANS
129-180	TRAFFIC CONTROL PLAN SHEETS
181-208	EROSION CONTROL PLAN SHEETS
209-296	CROSS SECTIONS
	HIGHWAY STANDARDS

DATE	
BY	
PLAN	
NO.	
NOTE BOOK	
NO.	
NO. OF WAY CHECKED	
NO. OF FILE NAME	
NO.	

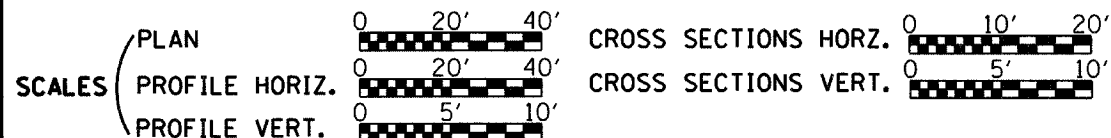

DESIGN DESIGNATIONS:
 Winter Avenue (F.A.U. 6998)
 ADT (2025) = 11,000
 Design Speed: 30 m.p.h.
 Highway Class: Minor Arterial

Bowman Avenue (F.A.U. 7405)
 ADT (2025) = 16,500
 Design Speed: 35 m.p.h.
 Highway Class: Arterial

Winter Avenue Total Length of Improvement = 2758.00 ft. = 0.522 mi.
 Bowman Avenue Total Length of Improvement = 1920.00 ft. = 0.364 mi.
 Total Length of Improvement = 4678.00 ft. = 0.886 mi.
 Net Length of Improvement = 3820.93 ft. = 0.724 mi.

JOINT UTILITY LOCATING INFORMATION FOR EXCAVATORS
 J.U.L.I.E. Telephone No. Toll Free 1-800-892-0123

UTILITIES NOTE:
 Utilities Shown Are As Reported to Us and As Indicated On Existing Utility Base Maps and Reference Data Provided to Us. No Attempt Has Been Made to Excavate, Uncover or Expose These Facilities to Field Check The Existence, Size, Depth, Condition, Capacity or Exact Location of These Utilities. For Additional Information Contact:

CITY OF DANVILLE ENGINEERING DIVISION OF THE PUBLIC WORKS DEPARTMENT 17 WEST MAIN STREET DANVILLE, IL 61832 PHONE: 217-431-2383 FAX: 217-431-2237	GAS: AMERINIP 2460 NORTH JASPER STREET DECATUR, IL 62526 PHONE: 1-800-755-5000 FAX: 217-425-4151
SANITARY SEWERS, STORM SEWERS: CITY OF DANVILLE SEWER DEPARTMENT 17 WEST MAIN STREET DANVILLE, IL 61832 PHONE: 217-431-2380 FAX: 217-431-2237	CABLE TELEVISION: INSIGHT COMMUNICATIONS 806 1/2 EAST MAIN STREET DANVILLE, IL 61832 PHONE: 217-443-2941 FAX: 217-443-3907
WATER: AQUA ILLINOIS 1300 WEST FAIRCHILD STREET DANVILLE, IL 61832 PHONE: 217-442-3063 FAX: 217-442-0178	TELEPHONE: AT&T 816 EAST VOORHEES STREET DANVILLE, IL 61832 PHONE: 217-443-7830 FAX: 217-443-7883
POWER: AMERINIP 1112 WEST ANTHONY DRIVE PO BOX 17070 URBANA, IL 61803-7070 PHONE: 1-800-755-5000 FAX: 217-424-7007	FIRE DEPARTMENT: DANVILLE FIRE DEPARTMENT 1111 NORTH GRIFFIN DANVILLE, IL 61832 EMERGENCY CALLS PHONE: 911 NON-EMERGENCY CALLS PHONE: 217-431-2350 FAX: 217-431-2359

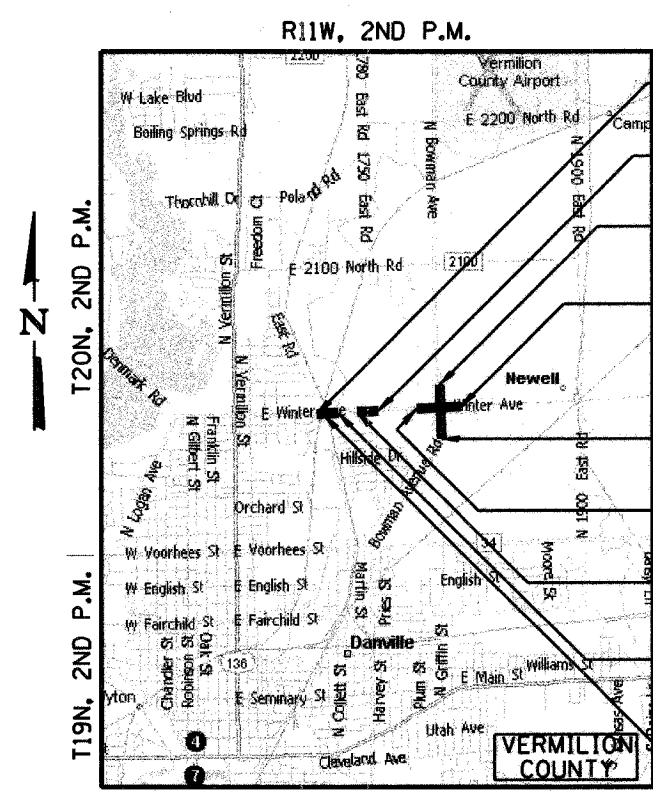

LOCATION MAP

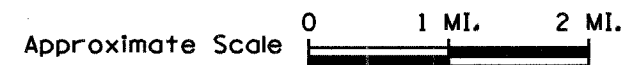

STA. 100+10.00	Improvement Begins
STA. 114+50.00	Omission Begins
STA. 73+40.00	Improvement Ends
STA. 156+35.00	Improvement Ends
STA. 54+20.00	Improvement Begins
STA. 141+50.00	Omission Ends
STA. 107+18.20	Omission Ends
STA. 105+51.20	Omission Begins
STA. 5526+96.28 TO 5528+38.07	Structure No. 092-6039 CSX Bridge over Winter Ave.

APPROVED _____ 20 07
R. David Acknille
 CITY ENGINEER

PASSED _____ 1/31 20 07
David A. Spaul
 DISTRICT 5 ENGINEER OF LOCAL ROADS AND STREETS

RELEASED FOR BID BASED ON LIMITED REVIEW
 _____ JANUARY 31, 20 07
Joseph E. Crowe
 REGIONAL ENGINEER

**STATE OF ILLINOIS
DEPARTMENT OF TRANSPORTATION**



Stephen M. Kerse
 Illinois Professional No. 62-048103

1-25-07
 Date
 Expires: 11-30-2007



PLAN	SURVEYED	DATE
	ALIGNED	
	NOTED	
	BY	
	DATE	
	BY	
	DATE	
	BY	
	DATE	
	BY	
	DATE	

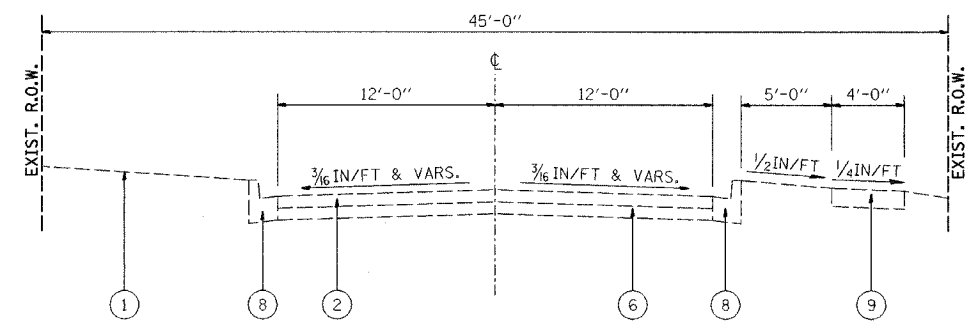

EXISTING TYPICAL SECTION E1
STA. 97+00 TO STA. 102+39.12

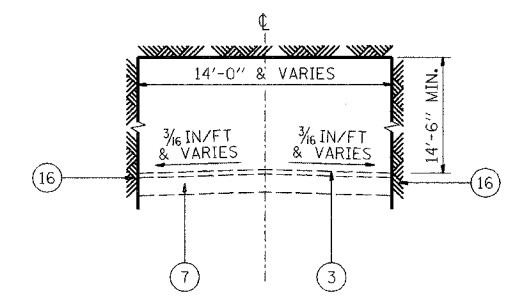

EXISTING TYPICAL SECTION E3
STA. 104+16.23 TO STA. 104+52.66

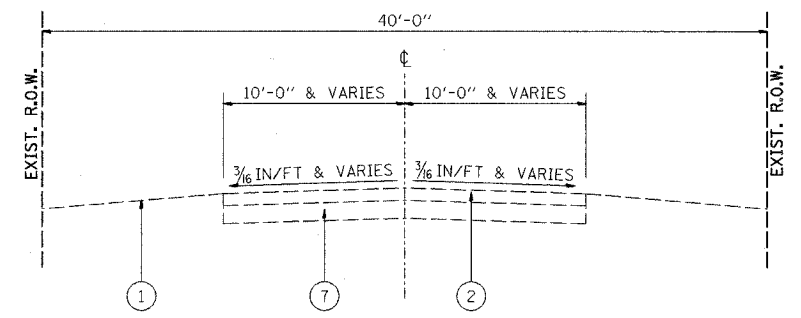

EXISTING TYPICAL SECTION E2
STA. 102+39.12 TO STA. 104+16.23

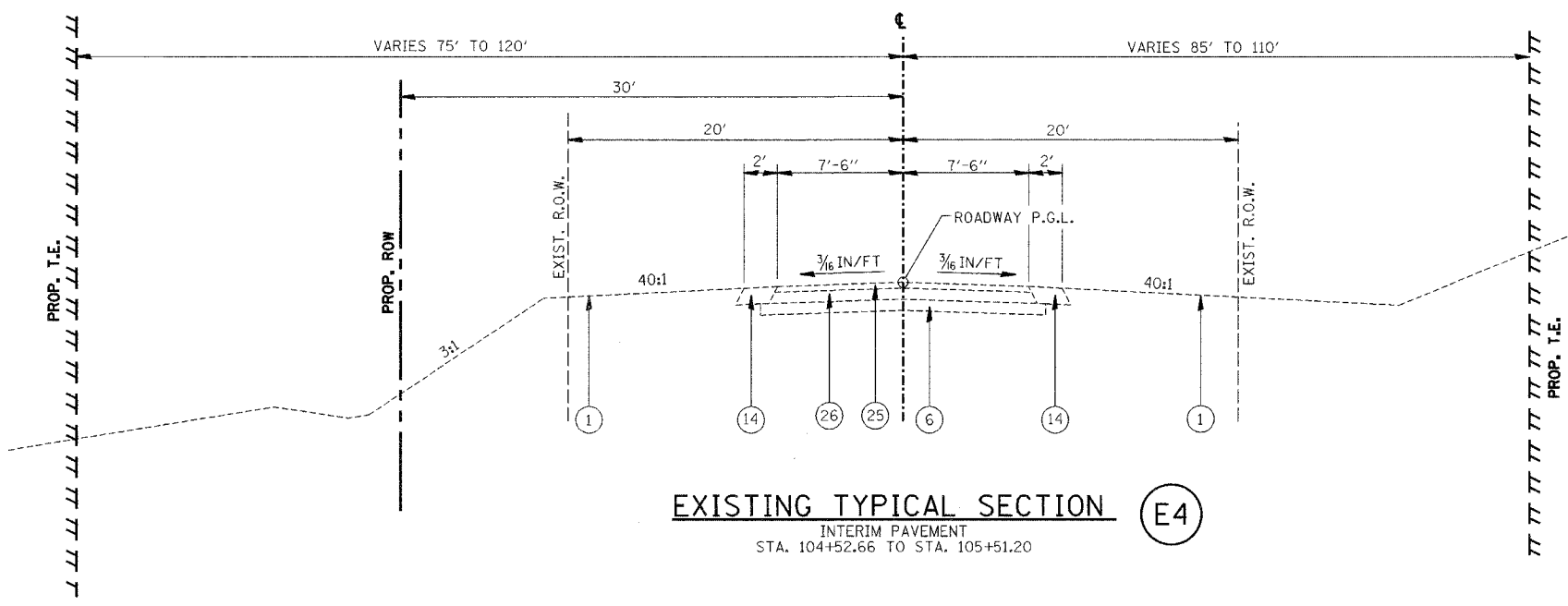

EXISTING TYPICAL SECTION E4
INTERIM PAVEMENT
STA. 104+52.66 TO STA. 105+51.20

LEGEND:

① GROUND LINE	⑦ AGG. BASE COURSE, 6"	⑮ CONC. DECK BEAMS 36"X27"	⑳ POLYMERIZED BITUMINOUS CONCRETE SURFACE COURSE, SUPERPAVE, MIX "D", N70, 2"
② BIT. SURFACE, 4"	⑧ COMB. C&G, TYPE B-6.12	⑯ ABUTMENT	㉑ POLYMERIZED BITUMINOUS CONCRETE BINDER COURSE, SUPERPAVE, IL-19.0, N70, 2 1/4"
③ O&C SURFACE, 1 1/2"	⑨ P.C.C. SIDEWALK, 5"	⑰ STEEL PLATE BEAM GUARDRAIL	㉒ BITUMINOUS PAVEMENT, 6"
④ O&C SURFACE, 2"	⑩ P.C.C. PAVEMENT, 9-6-9	⑱ BITUMINOUS CONCRETE BINDER COURSE, SUPERPAVE, IL-19.0, N70, 8"	㉓ BITUMINOUS CONCRETE SURFACE COURSE, SUPERPAVE, MIX "C", N50, 2"
⑤ O&C SURFACE, 4"	⑪ P.C.C. BASE COURSE, 8"	⑲ COMB. C&G TYPE B-6.24	㉔ BITUMINOUS CONCRETE BINDER COURSE, SUPERPAVE, IL-19.0, N50, 4"
⑥ AGG. BASE COURSE, 4"	⑫ BIT. BASE COURSE, 9 1/2"	⑳ AGG. BASE COURSE, TYPE A, 5.5"	
	⑬ BIT. SHOULDER, 6"	㉑ BITUMINOUS CONCRETE BINDER COURSE, SUPERPAVE, IL-19.0, N70, 5 3/4"	
	⑭ AGG. SHOULDER, TYPE B		

(E1) TO (E4) = LABELS FOR PLANS SHEET TO REFERENCE EXISTING TYPICALS

REVISIONS	
NAME	DATE

CITY OF DANVILLE, ILLINOIS
WINTER AVENUE RECONSTRUCTION
EXISTING TYPICAL SECTIONS
E1-E4
WINTER AVENUE

SCALE: NTS
DRAWN BY: SRS

DATE: 12/21/06
CHECKED BY: MBF

PLAN	SURVEYED	BY	DATE
	DESIGNED		
	CHECKED		
	IN CHARGE		
	NOTE BOOK		
	NO.		

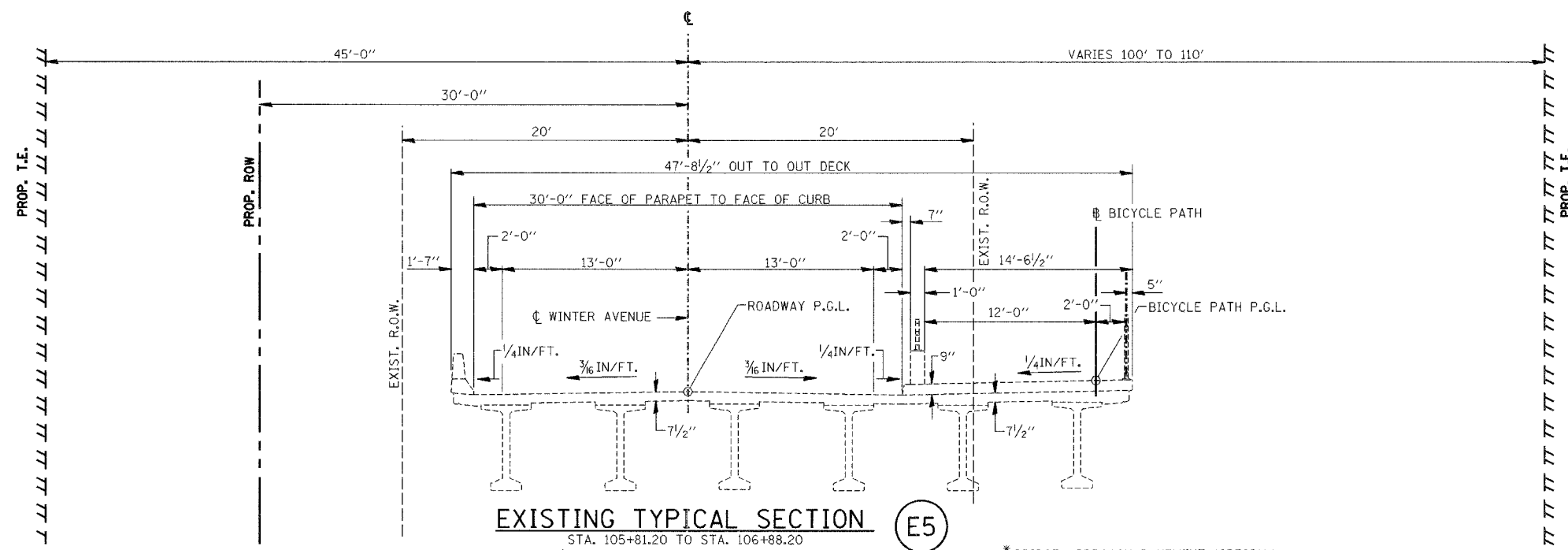

EXISTING TYPICAL SECTION E5
 STA. 105+81.20 TO STA. 106+88.20
 *STA. 105+51.20 TO STA. 105+81.20
 *STA. 106+88.20 TO STA. 107+18.20

* BRIDGE APPROACH PAVEMENT (SPECIAL)

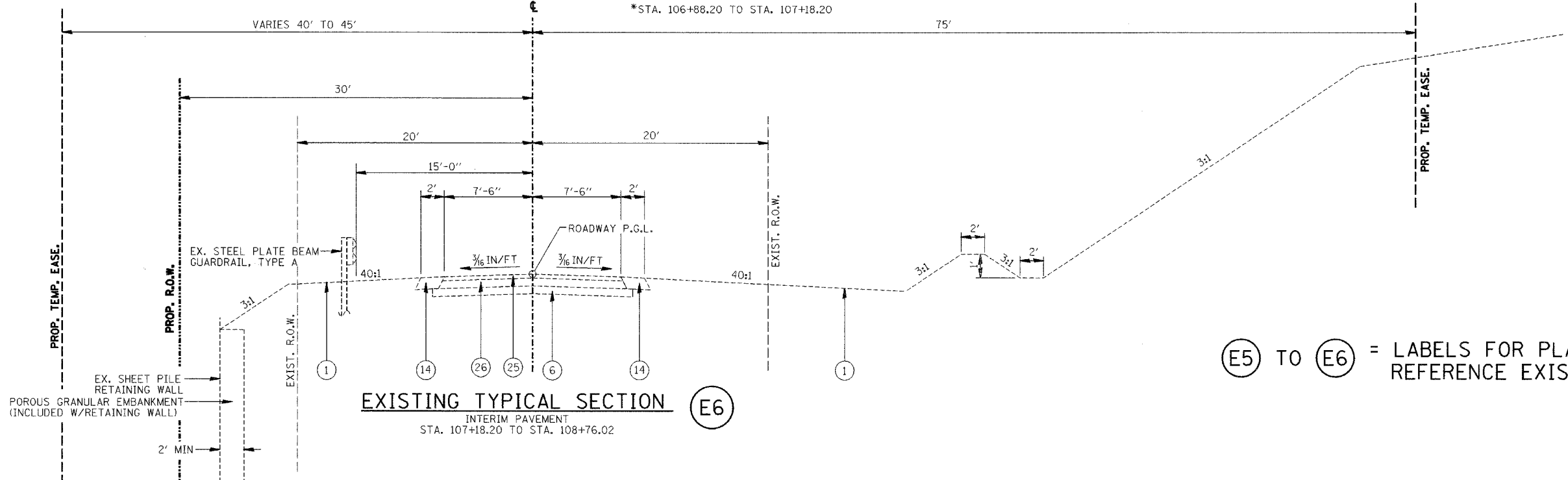

EXISTING TYPICAL SECTION E6
 INTERIM PAVEMENT
 STA. 107+18.20 TO STA. 108+76.02

(E5) TO (E6) = LABELS FOR PLANS SHEET TO REFERENCE EXISTING TYPICALS

LEGEND:

① GROUND LINE	⑦ AGG. BASE COURSE, 6"	⑮ CONC. DECK BEAMS 36"X27"	⑳ POLYMERIZED BITUMINOUS CONCRETE SURFACE COURSE, SUPERPAVE, MIX "D", N70, 2"
② BIT. SURFACE, 4"	⑧ COMB. C&G, TYPE B-6.12	⑯ ABUTMENT	㉑ POLYMERIZED BITUMINOUS CONCRETE BINDER COURSE, SUPERPAVE, IL-19.0, N70, 2 1/4"
③ O&C SURFACE, 1 1/2"	⑨ P.C.C. SIDEWALK, 5"	⑰ STEEL PLATE BEAM GUARDRAIL	㉒ BITUMINOUS PAVEMENT, 6"
④ O&C SURFACE, 2"	⑩ P.C.C. PAVEMENT, 9-6-9	⑱ BITUMINOUS CONCRETE BINDER COURSE, SUPERPAVE, IL-19.0, N70, 8"	㉓ BITUMINOUS CONCRETE SURFACE COURSE, SUPERPAVE, MIX "C", N50, 2"
⑤ O&C SURFACE, 4"	⑪ P.C.C. BASE COURSE, 8"	⑲ COMB. C&G TYPE B-6.24	㉔ BITUMINOUS CONCRETE BINDER COURSE, SUPERPAVE, IL-19.0, N50, 4"
⑥ AGG. BASE COURSE, 4"	⑫ BIT. BASE COURSE, 9 1/2"	⑳ AGG. BASE COURSE, TYPE A, 5 1/2"	
	⑬ BIT. SHOULDER, 6"	㉑ BITUMINOUS CONCRETE BINDER COURSE, SUPERPAVE, IL-19.0, N70, 5 3/4"	
	⑭ AGG. SHOULDER, TYPE B		

REVISIONS	
NAME	DATE

CITY OF DANVILLE, ILLINOIS
WINTER AVENUE RECONSTRUCTION
EXISTING TYPICAL SECTIONS
E5-E6
WINTER AVENUE

SCALE: NTS
 DRAWN BY: SRS

DATE: 12/21/06
 CHECKED BY: MBF

PLAN	SURVEYED	DATE
	FLOWN	
	NOTED	
	BY	
	NO. OF WAY CHECKED	
	CAD FILE NAME	

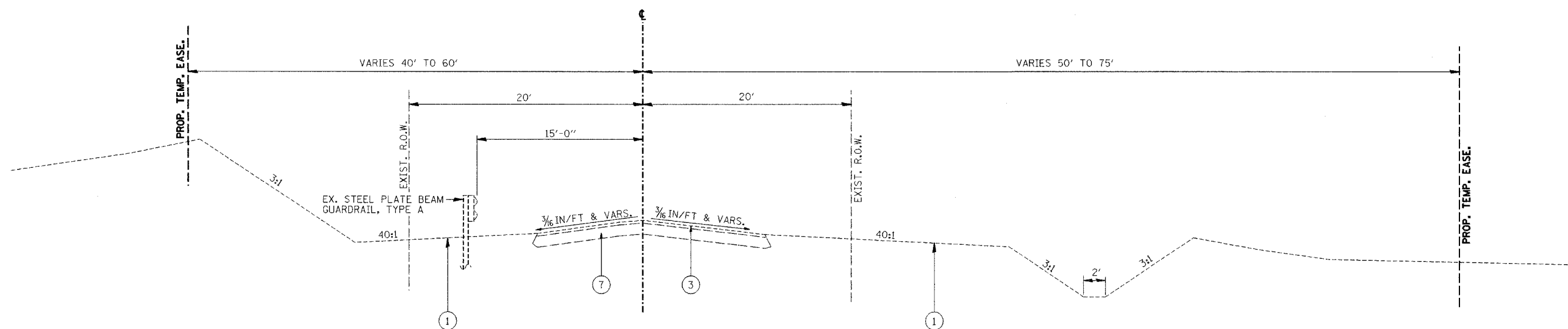

EXISTING TYPICAL SECTION E7

STA. 108+76.02 TO STA. 111+50 LT.
STA. 108+76.02 TO STA. 111+00 RT.

E7 TO E8 = LABELS FOR PLANS SHEET TO REFERENCE EXISTING TYPICALS

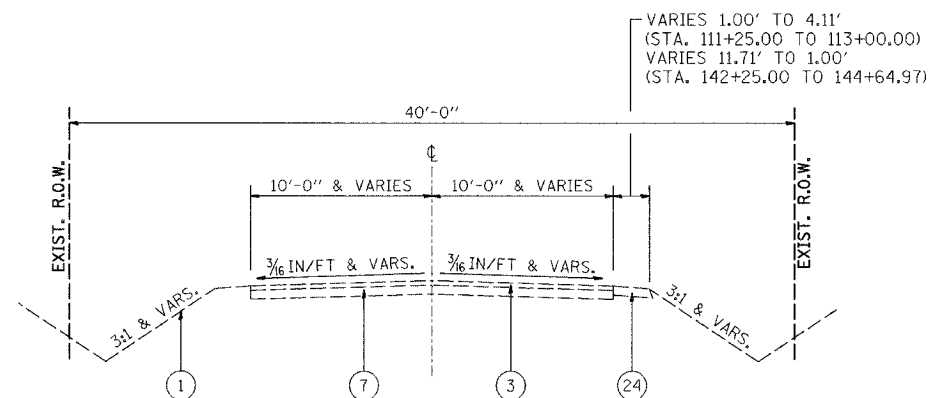

EXISTING TYPICAL SECTION E8

STA. 111+00 (RT) & 111+50 (LT) TO STA. 113+00.00
STA. 142+25.00 TO STA. 146+75.44

LEGEND:

1 GROUND LINE	7 AGG. BASE COURSE, 6"	13 BIT. SHOULDER, 6"	19 COMB. C&G TYPE B-6.24
2 BIT. SURFACE, 4"	8 COMB. C&G, TYPE B-6.12	14 AGG. SHOULDER, TYPE B	20 AGG. BASE COURSE, TYPE A, 5.5"
3 O&C SURFACE, 1 1/2"	9 P.C.C. SIDEWALK, 5"	15 CONC. DECK BEAMS 36"X27"	21 BITUMINOUS CONCRETE BINDER COURSE, SUPERPAVE, IL-19.0, N70, 5 3/4"
4 O&C SURFACE, 2"	10 P.C.C. PAVEMENT, 9-6-9	16 ABUTMENT	22 POLYMERIZED BITUMINOUS CONCRETE SURFACE COURSE, SUPERPAVE, MIX "D", N70, 2"
5 O&C SURFACE, 4"	11 P.C.C. BASE COURSE, 8"	17 STEEL PLATE BEAM GUARDRAIL	23 POLYMERIZED BITUMINOUS CONCRETE BINDER COURSE, SUPERPAVE, IL-19.0, N70, 2 1/4"
6 AGG. BASE COURSE, 4"	12 BIT. BASE COURSE, 9 1/2"	18 BITUMINOUS CONCRETE BINDER COURSE, SUPERPAVE, IL-19.0, N70, 8"	24 BITUMINOUS PAVEMENT, 6"

REVISIONS	
NAME	DATE

CITY OF DANVILLE, ILLINOIS
WINTER AVENUE RECONSTRUCTION
EXISTING TYPICAL SECTIONS
E7-E8
WINTER AVENUE

SCALE: NTS
DRAWN BY: SRS
DATE: 12/21/06
CHECKED BY: MBF

PLAN	SURVEYED	DATE
	PLANNED	
	DESIGNED	
	CHECKED	
	BY	
	DATE	
	NO.	

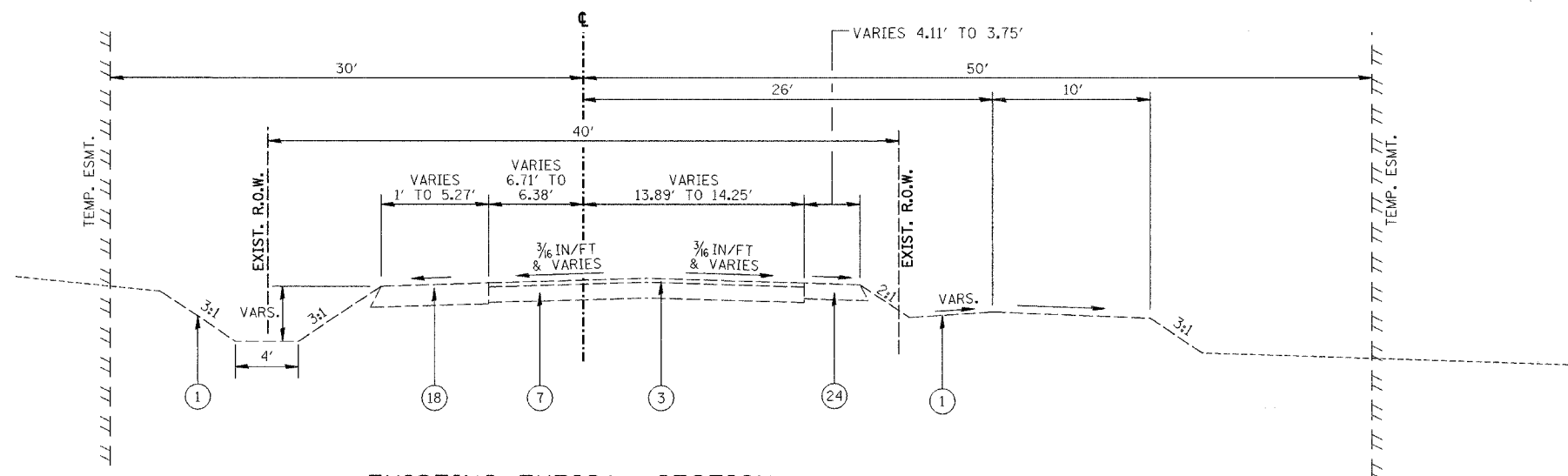

EXISTING TYPICAL SECTION (E9)
STA. 113+00.00 TO STA. 113+75.00

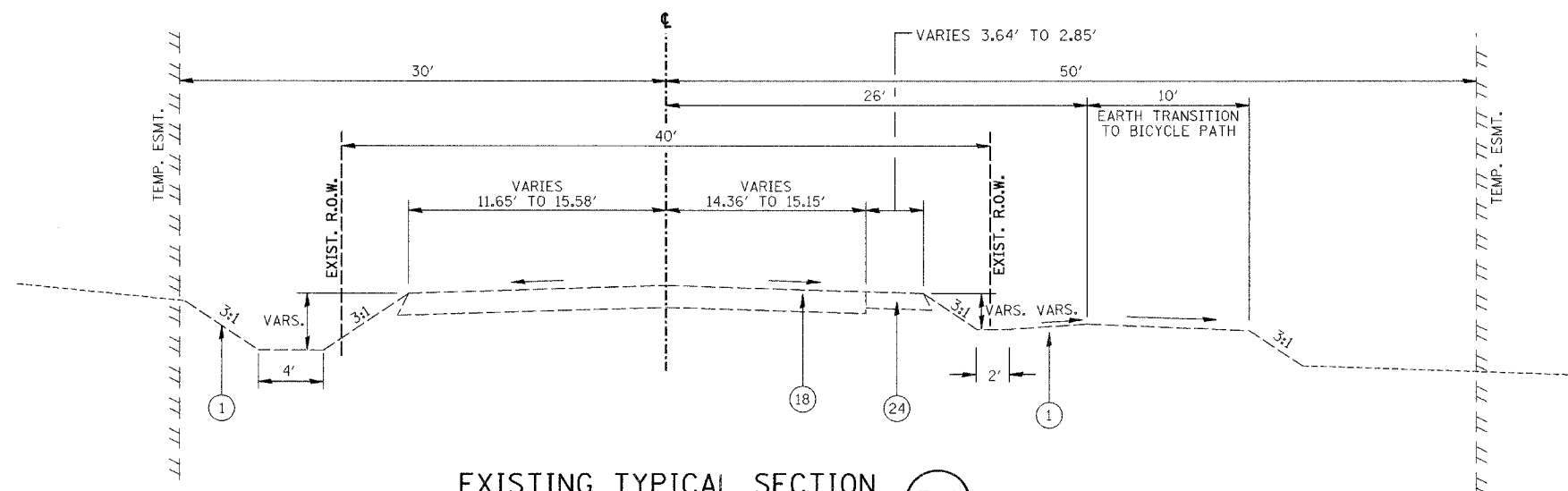

EXISTING TYPICAL SECTION (E10)
STA. 113+75.00 TO STA. 114+50.00

LEGEND:

(1) GROUND LINE	(7) AGG. BASE COURSE, 6"	(13) BIT. SHOULDER, 6"	(19) COMB. C&G TYPE B-6.24
(2) BIT. SURFACE, 4"	(8) COMB. C&G, TYPE B-6.12	(14) AGG. SHOULDER, TYPE B	(20) AGG. BASE COURSE, TYPE A, 5.5"
(3) O&C SURFACE, 1 1/2"	(9) P.C.C. SIDEWALK, 5"	(15) CONC. DECK BEAMS 36"x27"	(21) BITUMINOUS CONCRETE BINDER COURSE, SUPERPAVE, IL-19.0, N70, 5 3/4"
(4) O&C SURFACE, 2"	(10) P.C.C. PAVEMENT, 9-6-9	(16) ABUTMENT	(22) POLYMERIZED BITUMINOUS CONCRETE SURFACE COURSE, SUPERPAVE, MIX "D", N70, 2"
(5) O&C SURFACE, 4"	(11) P.C.C. BASE COURSE, 8"	(17) STEEL PLATE BEAM GUARDRAIL	(23) POLYMERIZED BITUMINOUS CONCRETE BINDER COURSE, SUPERPAVE, IL-19.0, N70, 2 1/4"
(6) AGG. BASE COURSE, 4"	(12) BIT. BASE COURSE, 9 1/2"	(18) BITUMINOUS CONCRETE BINDER COURSE, SUPERPAVE, IL-19.0, N70, 8"	(24) BITUMINOUS PAVEMENT, 6"

(E9) TO (E10) = LABELS FOR PLANS SHEET TO REFERENCE EXISTING TYPICALS

REVISIONS	
NAME	DATE

CITY OF DANVILLE, ILLINOIS
WINTER AVENUE RECONSTRUCTION
EXISTING TYPICAL SECTIONS
E9-E10
WINTER AVENUE

SCALE: NTS
DRAWN BY: SRS
DATE: 12/21/06
CHECKED BY: MBF

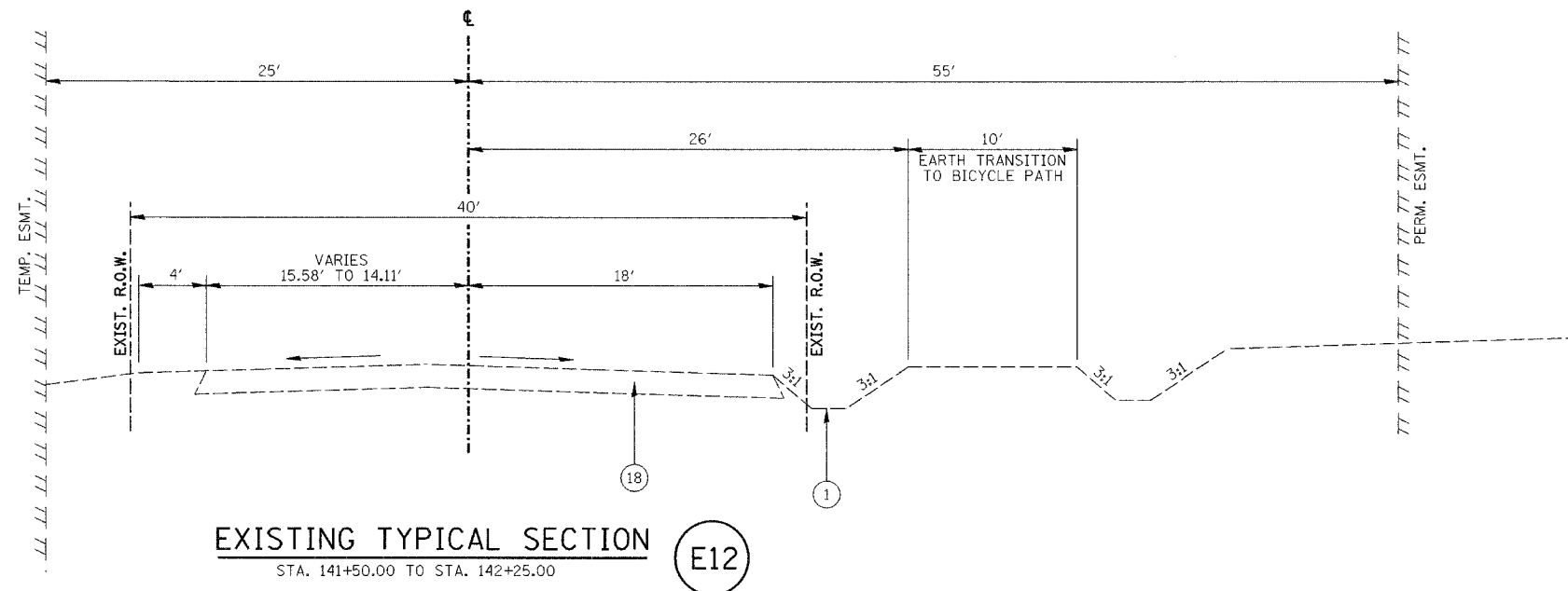
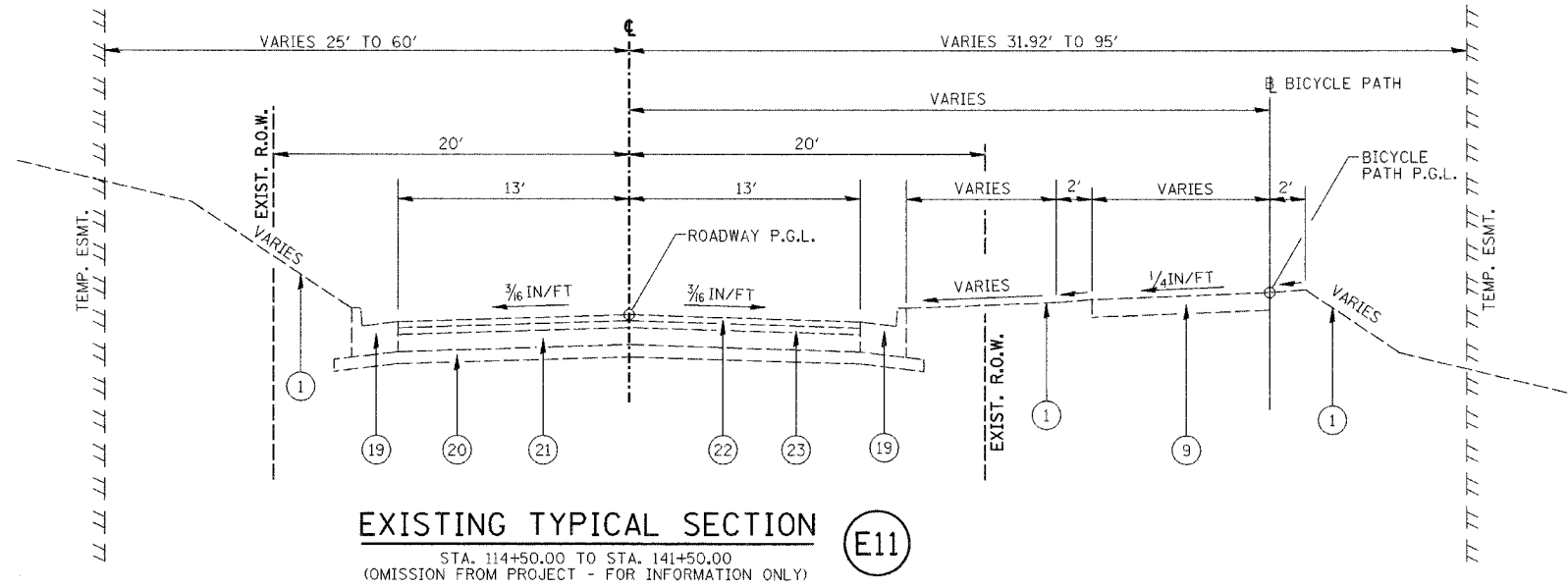

LEGEND:

① GROUND LINE	⑦ AGG. BASE COURSE, 6"	⑬ BIT. SHOULDER, 6"	⑲ COMB. C&G TYPE B-6.24
② BIT. SURFACE, 4"	⑧ COMB. C&G, TYPE B-6.12	⑭ AGG. SHOULDER, TYPE B	⑳ AGG. BASE COURSE, TYPE A, 5.5"
③ O&C SURFACE, 1 1/2"	⑨ P.C.C. SIDEWALK, 5"	⑮ CONC. DECK BEAMS 36"X27"	㉑ BITUMINOUS CONCRETE BINDER COURSE, SUPERPAVE, IL-19.0, N70, 5 3/4"
④ O&C SURFACE, 2"	⑩ P.C.C. PAVEMENT, 9-6-9	⑯ ABUTMENT	㉒ POLYMERIZED BITUMINOUS CONCRETE SURFACE COURSE, SUPERPAVE, MIX "D", N70, 2"
⑤ O&C SURFACE, 4"	⑪ P.C.C. BASE COURSE, 8"	⑰ STEEL PLATE BEAM GUARDRAIL	㉓ POLYMERIZED BITUMINOUS CONCRETE BINDER COURSE, SUPERPAVE, IL-19.0, N70, 2 1/4"
⑥ AGG. BASE COURSE, 4"	⑫ BIT. BASE COURSE, 9 1/2"	⑱ BITUMINOUS CONCRETE BINDER COURSE, SUPERPAVE, IL-19.0, N70, 8"	㉔ BITUMINOUS PAVEMENT, 6"

ⓔ11 TO ⓔ12 = LABELS FOR PLANS SHEET TO REFERENCE EXISTING TYPICALS

REVISIONS	
NAME	DATE

CITY OF DANVILLE, ILLINOIS
 WINTER AVENUE RECONSTRUCTION
 EXISTING TYPICAL SECTIONS
 E11-E12
 WINTER AVENUE

SCALE: NTS
 DRAWN BY: SRS

DATE: 12/21/06
 CHECKED BY: MBF

PLAN	SURVEYED	BY	DATE
	NOTED		
	DESIGNED		
	CHECKED		
	BY		
	DATE		
	NO.		

PLAN	SURVEYED	DATE
	PLANNED	
	NOTED	
	BY	
	DATE	
	NO. OF MAY CHECKED	
	NO. OF FILE CHECKED	
	NO. OF FILE NAME	
	NO.	

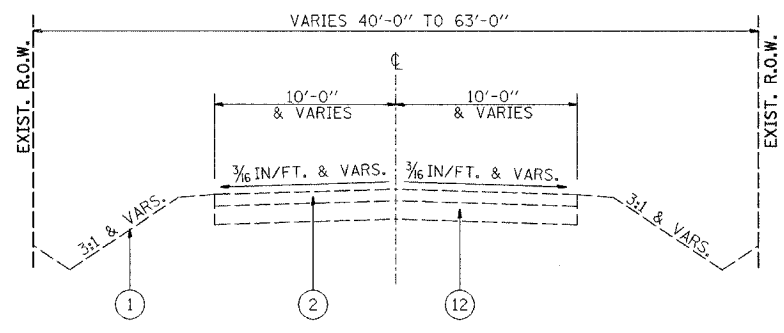

EXISTING TYPICAL SECTION (E13)
STA. 146+75.44 TO STA. 149+10.31

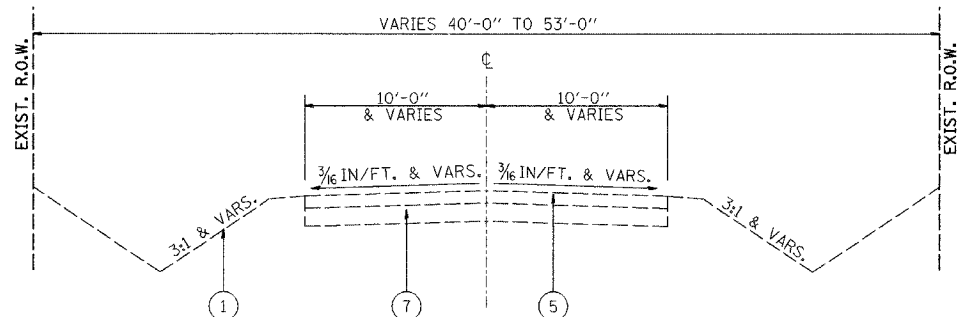

EXISTING TYPICAL SECTION (E14)
STA. 149+10.31 TO STA. 157+00.00

LEGEND:

(1) GROUND LINE	(7) AGG. BASE COURSE, 6"	(13) BIT. SHOULDER, 6"	(19) COMB. C&G TYPE B-6.24
(2) BIT. SURFACE, 4"	(8) COMB. C&G, TYPE B-6.12	(14) AGG. SHOULDER, TYPE B	(20) AGG. BASE COURSE, TYPE A, 5.5"
(3) O&C SURFACE, 1 1/2"	(9) P.C.C. SIDEWALK, 5"	(15) CONC. DECK BEAMS 36"X27"	(21) BITUMINOUS CONCRETE BINDER COURSE, SUPERPAVE, IL-19.0, N70, 5 3/4"
(4) O&C SURFACE, 2"	(10) P.C.C. PAVEMENT, 9-6-9	(16) ABUTMENT	(22) POLYMERIZED BITUMINOUS CONCRETE SURFACE COURSE, SUPERPAVE, MIX "D", N70, 2"
(5) O&C SURFACE, 4"	(11) P.C.C. BASE COURSE, 8"	(17) STEEL PLATE BEAM GUARDRAIL	(23) POLYMERIZED BITUMINOUS CONCRETE BINDER COURSE, SUPERPAVE, IL-19.0, N70, 2 1/4"
(6) AGG. BASE COURSE, 4"	(12) BIT. BASE COURSE, 9 1/2"	(18) BITUMINOUS CONCRETE BINDER COURSE, SUPERPAVE, IL-19.0, N70, 8"	(24) BITUMINOUS PAVEMENT, 6"

(E13) TO (E14) = LABELS FOR PLANS SHEET TO REFERENCE EXISTING TYPICALS

REVISIONS	
NAME	DATE

CITY OF DANVILLE, ILLINOIS
WINTER AVENUE RECONSTRUCTION
EXISTING TYPICAL SECTIONS
E13-E14
WINTER AVENUE

SCALE: NTS
DRAWN BY: SRS

DATE: 12/21/06
CHECKED BY: MBF

PLAN	SURVEYED	DATE
	BY	
	REVISIONS	
	NOTED	
	PLANNED	
	DESIGNED	
	CHECKED	
	DATE	
	BY	
	DATE	
	BY	
	DATE	

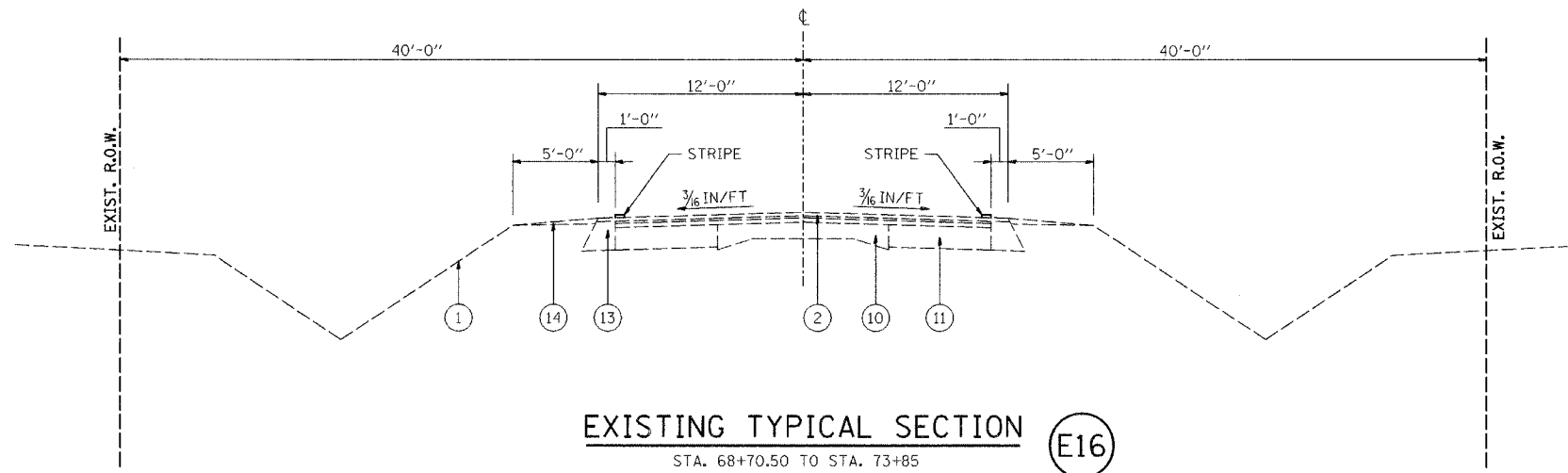
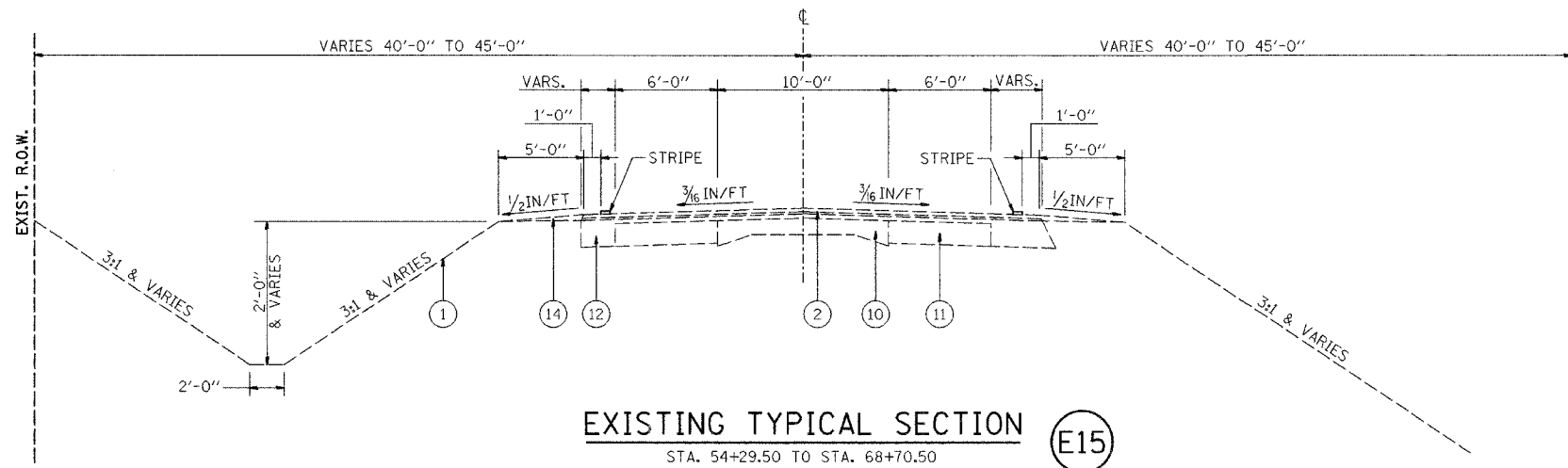

LEGEND:

① GROUND LINE	⑦ AGG. BASE COURSE, 6"	⑬ BIT. SHOULDER, 6"	⑰ COMB. C&G TYPE B-6.24
② BIT. SURFACE, 4"	⑧ COMB. C&G, TYPE B-6.12	⑭ AGG. SHOULDER, TYPE B	⑱ AGG. BASE COURSE, TYPE A, 5.5"
③ O&C SURFACE, 1/2"	⑨ P.C.C. SIDEWALK, 5"	⑮ CONC. DECK BEAMS 36"X27"	⑳ BITUMINOUS CONCRETE BINDER COURSE, SUPERPAVE, IL-19.0, N70, 5 3/4"
④ O&C SURFACE, 2"	⑩ P.C.C. PAVEMENT, 9-6-9	⑯ ABUTMENT	㉑ POLYMERIZED BITUMINOUS CONCRETE SURFACE COURSE, SUPERPAVE, MIX "D", N70, 2"
⑤ O&C SURFACE, 4"	⑪ P.C.C. BASE COURSE, 8"	⑰ STEEL PLATE BEAM GUARDRAIL	㉒ POLYMERIZED BITUMINOUS CONCRETE BINDER COURSE, SUPERPAVE, IL-19.0, N70, 2 1/4"
⑥ AGG. BASE COURSE, 4"	⑫ BIT. BASE COURSE, 9/2"	⑱ BITUMINOUS CONCRETE BINDER COURSE, SUPERPAVE, IL-19.0, N70, 8"	㉓ BITUMINOUS PAVEMENT, 6"

ⓔ15 TO ⓔ16 = LABELS FOR PLANS SHEET TO REFERENCE EXISTING TYPICALS

REVISIONS	
NAME	DATE

CITY OF DANVILLE, ILLINOIS
WINTER AVENUE RECONSTRUCTION
EXISTING TYPICAL SECTIONS
E15-E16
BOWMAN AVENUE

SCALE: NTS
 DRAWN BY: SRS
 DATE: 12/21/06
 CHECKED BY: MBF

F.A.J. RTE.	SECTION	COUNTY	TOTAL SHEETS	SHEET NO.
6998	99-00209-01-PV	VERMILION	296	9
STA.	TO STA.			
FED. ROAD DIST. NO.	ILLINOIS	FED. AID PROJECT-		
CONTRACT NO.: 91358				

PLAN	SURVEYED	DATE
	BY	
	NOTED	
	BY	
	DATE	
	BY	
	DATE	
	BY	
	DATE	

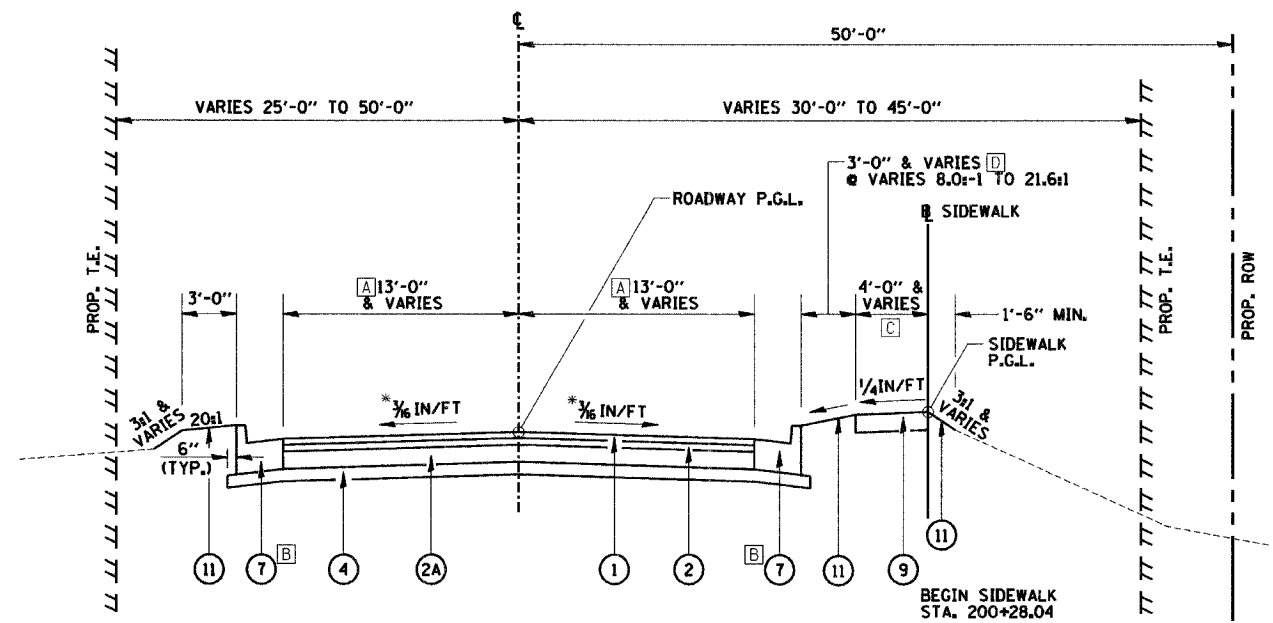

PROPOSED TYPICAL SECTION P1
STA. 100+10 TO STA. 102+25

* TRANSITION PAVEMENT SLOPE TO MATCH EXISTING STA. 100+10 TO STA. 100+60

- A STA. 100+10 TO STA. 100+60 VARIES 11'-8" TO 13'-0"
- B STA. 100+10 TO STA. 100+60 VARIES B-6.12 TO B-6.24
- C STA. 101+75 TO STA. 102+25 VARIES 4'-0" TO 10'-0"
- D STA. 101+75 TO STA. 102+25 VARIES 3'-0" TO 4'-5"

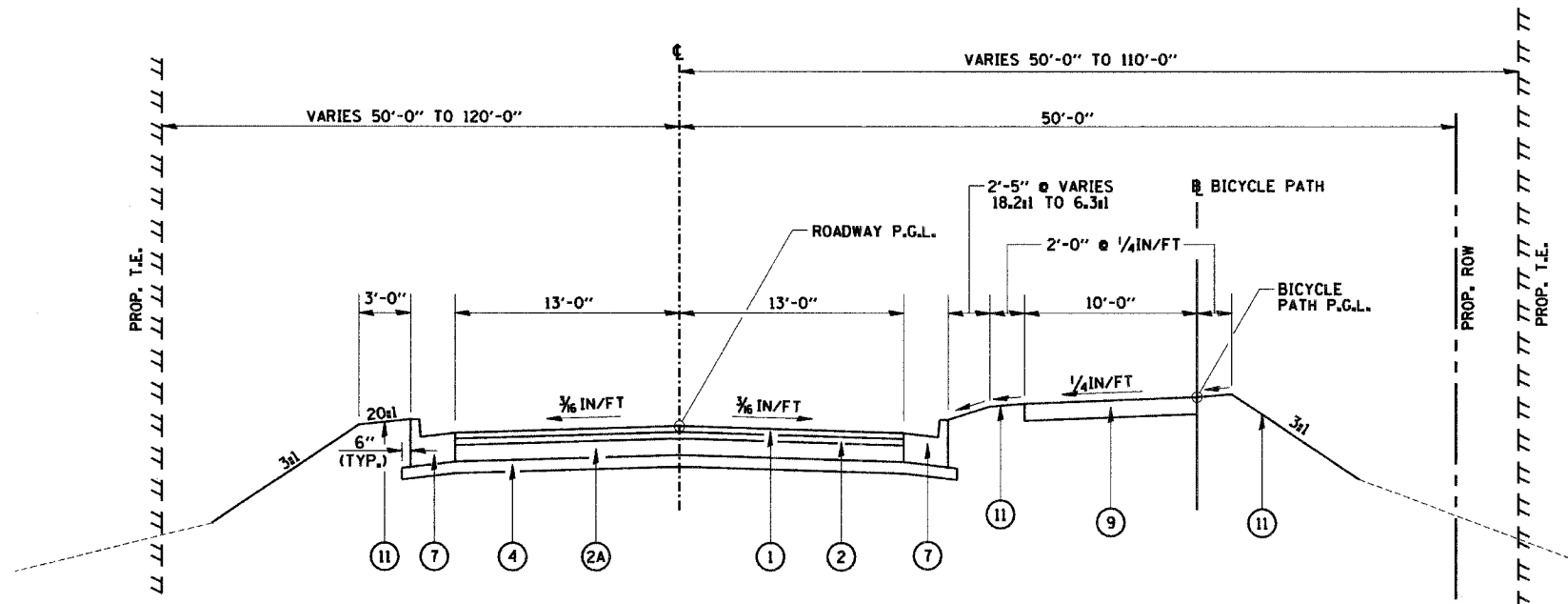

PROPOSED TYPICAL SECTION P2
STA. 102+25 TO STA. 104+20.35

PROPOSED LEGEND:

- 1 POLYMERIZED HOT-MIX ASPHALT SURFACE COURSE, MIX "T", N70, 2"
- 2 POLYMERIZED HOT-MIX ASPHALT BINDER COURSE, IL-19.0, N70, 2 1/4"
- 2A HOT-MIX ASPHALT BINDER COURSE, IL-19.0, N70, 5 1/4"
- 4 AGGREGATE BASE COURSE, TYPE A, 5.5"
- 5 AGGREGATE BASE COURSE, TYPE A, 6.5"
- 7 COMBINATION CONCRETE CURB & GUTTER, TYPE B-6.24
- 8 COMBINATION CONCRETE CURB & GUTTER, TYPE B-9.24
- 9 PORTLAND CEMENT CONCRETE SIDEWALK, 5"
- 10 PORTLAND CEMENT CONCRETE SIDEWALK, 5", SPECIAL
- 11 SEEDING, CLASS 1A
- 12 AGGREGATE SHOULDER, TYPE A, 6"
- 14 STONE RIPRAP, CLASS A2 (SPECIAL)

P1 to P2 = LABELS FOR PLANS SHEET TO REFERENCE PROPOSED TYPICALS

REVISIONS	
NAME	DATE

CITY OF DANVILLE, ILLINOIS
WINTER AVENUE RECONSTRUCTION
 PROPOSED TYPICAL SECTIONS
 P1-P2
 WINTER AVENUE

SCALE: NTS
 DRAWN BY: NIL
 DATE: 12/21/06
 CHECKED BY: MBF

PLAN	DATE
SURVEYED	BY
DESIGNED	
CHECKED	
NOTE BOOK	
NO.	

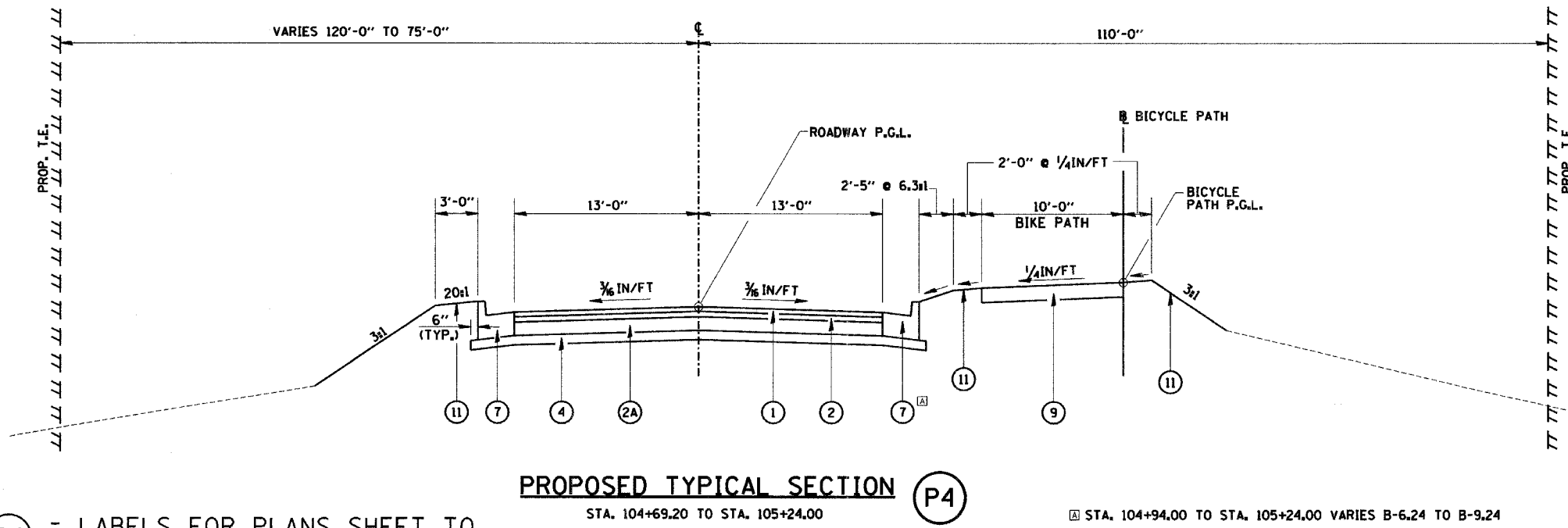
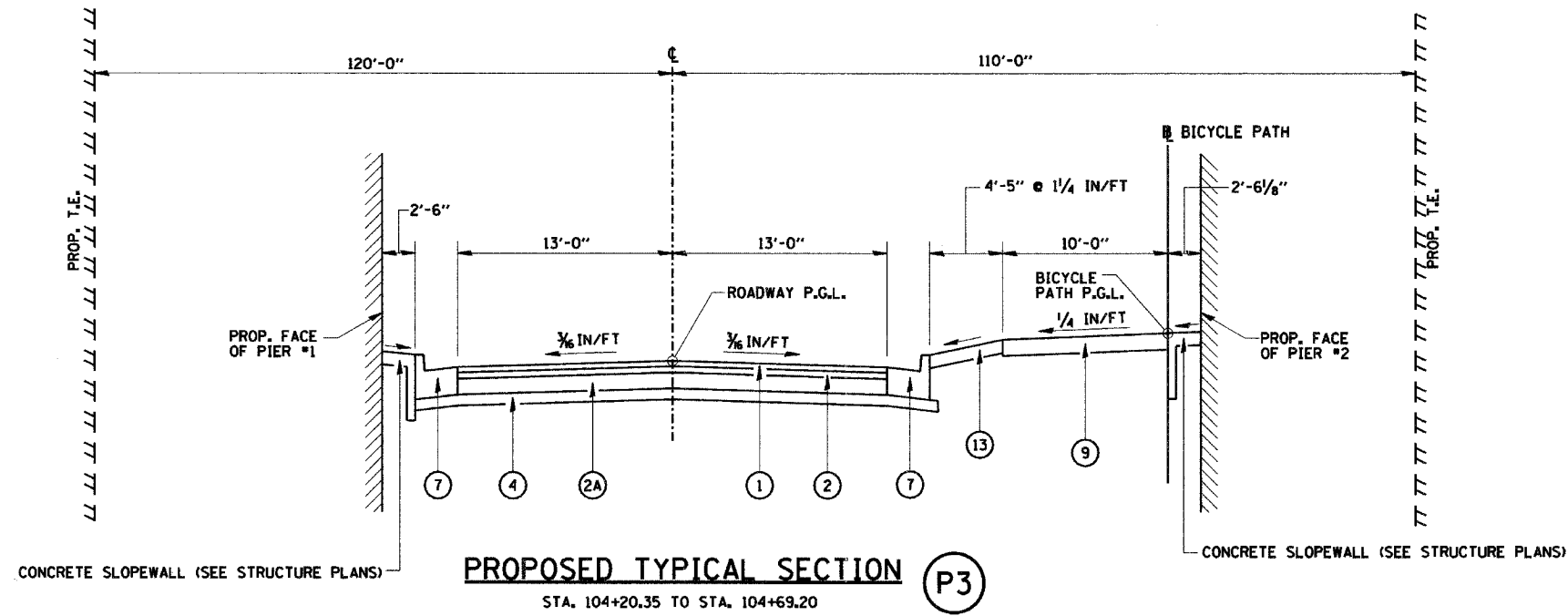

PROPOSED LEGEND:

- ① POLYMERIZED HOT-MIX ASPHALT SURFACE COURSE, MI ("D", N70, 2"
- ② POLYMERIZED HOT-MIX ASPHALT BINDER COURSE, IL-13.0, N70, 2 1/4"
- ②A HOT-MIX ASPHALT BINDER COURSE, IL-19.0, N70, 5 3/4"
- ④ AGGREGATE BASE COURSE, TYPE A, 5.5"
- ⑤ AGGREGATE BASE COURSE, TYPE A, 6.5"
- ⑦ COMBINATION CONCRETE CURB & GUTTER, TYPE B-6.24
- ⑧ COMBINATION CONCRETE CURB & GUTTER, TYPE B-9.24
- ⑨ PORTLAND CEMENT CONCRETE SIDEWALK, 5"
- ⑩ PORTLAND CEMENT CONCRETE SIDEWALK, 5", SPECIAL
- ⑪ SEEDING, CLASS 1A
- ⑫ AGGREGATE SHOULDER, TYPE A, 6"
- ⑬ CONCRETE MEDIAN SURFACE, 4" (SPECIAL)
- ⑭ STONE RIPRAP, CLASS A2 (SPECIAL)

Ⓟ TO Ⓟ = LABELS FOR PLANS SHEET TO REFERENCE PROPOSED TYPICALS

Ⓟ STA. 104+94.00 TO STA. 105+24.00 VARIES B-6.24 TO B-9.24

REVISIONS	
NAME	DATE

CITY OF DANVILLE, ILLINOIS
WINTER AVENUE RECONSTRUCTION
PROPOSED TYPICAL SECTIONS
P3-P4
WINTER AVENUE

SCALE: NTS
DRAWN BY: NIL

DATE: 12/21/06
CHECKED BY: MBF

F.A.D. RTE.	SECTION	COUNTY	TOTAL SHEETS	SHEET NO.
6998	99-00209-01-PV	VERMILION	296	11
STA.	TO STA.			
FED. ROAD DIST. NO. ILLINOIS	FED. AID PROJECT-			

CONTRACT NO.: 91358

DATE	BY
SURVEYED	
DESIGNED	
CHECKED	
IN CHARGE	
NOTE BOOK NO.	
ADD. FILE NAME	

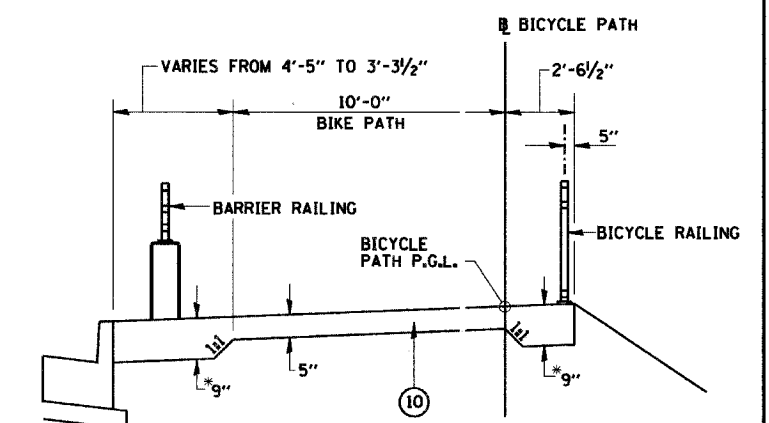
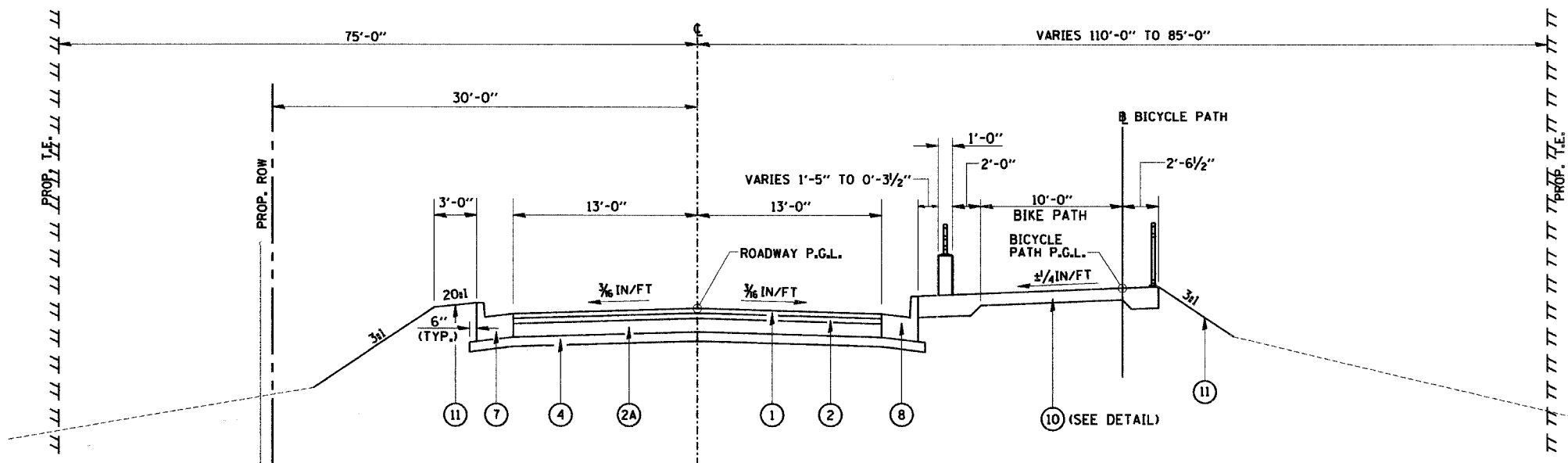

* ADDED BIKE PATH THICKNESS IS INCLUDED IN PAY ITEM (10) AND NO ADDITIONAL COMPENSATION WILL BE ALLOWED.

DETAIL

PROPOSED TYPICAL SECTION P5
 STA. 105+24 TO STA. 105+51.20 (WINTER AVENUE)
 STA. 205+23.67 TO STA. 205+61.98 (BICYCLE PATH)

STA. 105+51.20 TO 107+18.20 (WINTER AVENUE)
 STA. 205+61.98 TO 207+07.94 (BICYCLE PATH)
 BUILT IN CONTRACT 2
 SEE EXISTING TYPICAL SECTION E5

PROPOSED LEGEND:

- ① POLYMERIZED HOT-MIX ASPHALT SURFACE COURSE, MIX "D", N70, 2"
- ② POLYMERIZED HOT-MIX ASPHALT BINDER COURSE, IL-19.0, N7, 2 1/4"
- ②A HOT-MIX ASPHALT BINDER COURSE, IL-19.0, N70, 5 3/4"
- ④ AGGREGATE BASE COURSE, TYPE A, 5.5"
- ⑤ AGGREGATE BASE COURSE, TYPE A, 6.5"
- ⑦ COMBINATION CONCRETE CURB & GUTTER, TYPE B-6.24
- ⑧ COMBINATION CONCRETE CURB & GUTTER, TYPE B-9.24
- ⑨ PORTLAND CEMENT CONCRETE: SIDEWALK, 5"
- ⑩ PORTLAND CEMENT CONCRETE: SIDEWALK, 5", SPECIAL
- ⑪ SEEDING, CLASS 1A
- ⑫ AGGREGATE SHOULDER, TYPE A, 6"
- ⑭ STONE RIPRAP, CLASS A2 (SPECIAL)

P5 = LABEL FOR PLANS SHEET TO REFERENCE PROPOSED TYPICALS

REVISIONS	
NAME	DATE

CITY OF DANVILLE, ILLINOIS
 WINTER AVENUE RECONSTRUCTION
 PROPOSED TYPICAL SECTIONS
 P5
 WINTER AVENUE

SCALE: NTS
 DRAWN BY: NIL
 DATE: 12/21/06
 CHECKED BY: MBF

PLAN	SURVEYED	DATE
	PLOTTED	
	CHECKED	
	BY	
	NO. OF WAYS CHECKED	
	CADD FILE NAME	
	NO.	

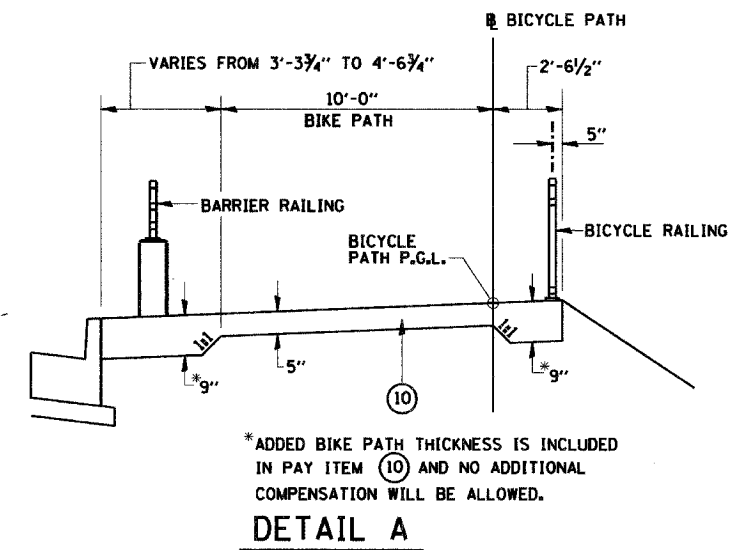
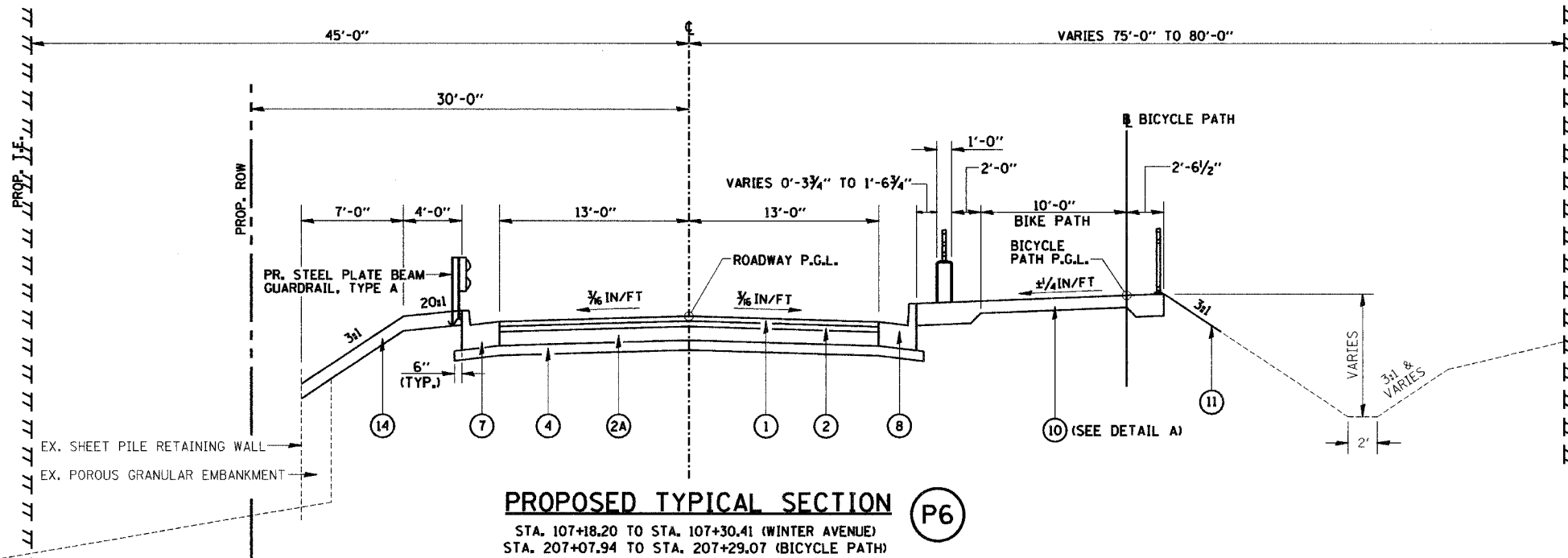

PROPOSED TYPICAL SECTION P6
 STA. 107+18.20 TO STA. 107+30.41 (WINTER AVENUE)
 STA. 207+07.94 TO STA. 207+29.07 (BICYCLE PATH)

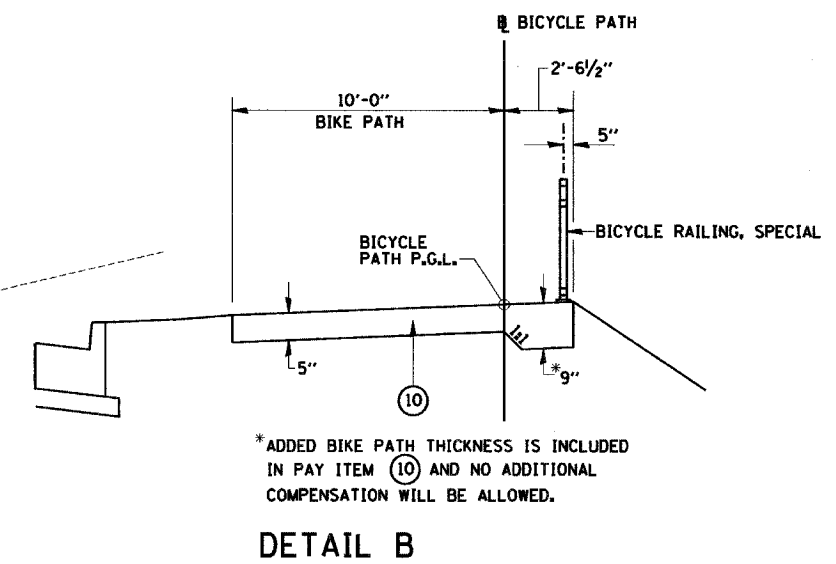
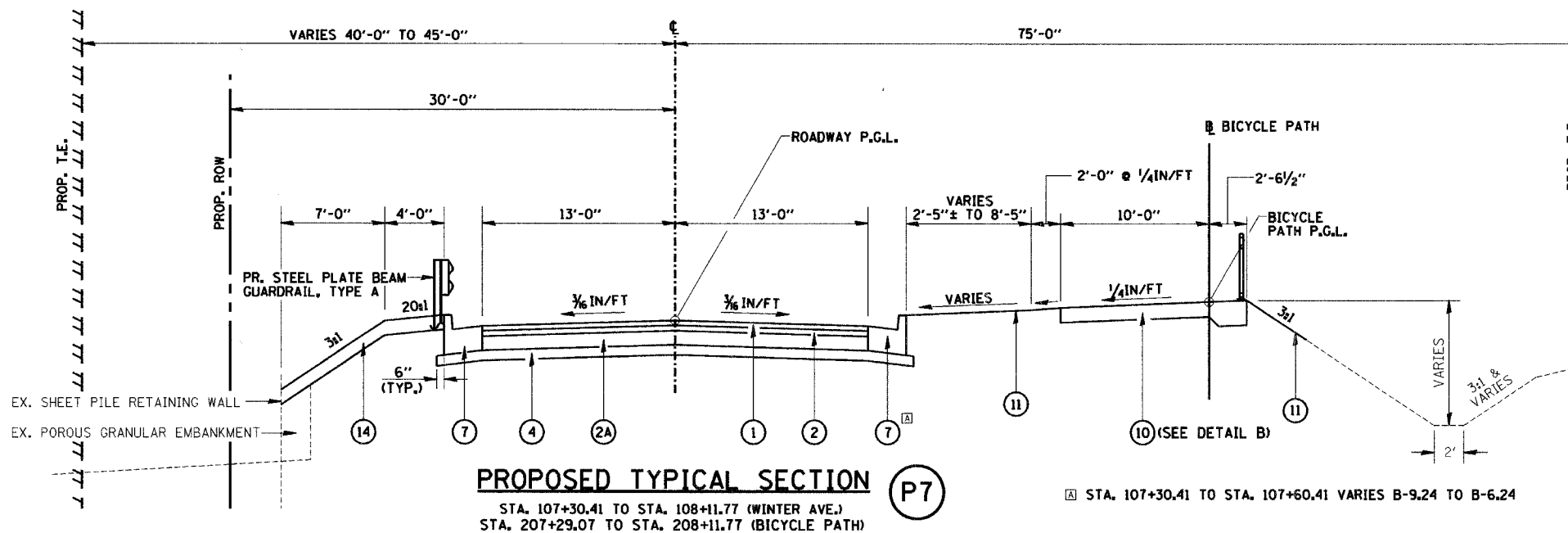

PROPOSED TYPICAL SECTION P7
 STA. 107+30.41 TO STA. 108+11.77 (WINTER AVE.)
 STA. 207+29.07 TO STA. 208+11.77 (BICYCLE PATH)

Ⓜ STA. 107+30.41 TO STA. 107+60.41 VARIES B-9.24 TO B-6.24

PROPOSED LEGEND:

- | | |
|---|---|
| ① POLYMERIZED HOT-MIX ASPHALT SURFACE COURSE, MIX "D", N70, 2" | ⑦ COMBINATION CONCRETE CURB & GUTTER, TYPE B-6.24 |
| ② POLYMERIZED HOT-MIX ASPHALT BINDER COURSE, IL-19.0, N70, 2 1/4" | ⑧ COMBINATION CONCRETE CURB & GUTTER, TYPE B-9.24 |
| ②A HOT-MIX ASPHALT BINDER COURSE, IL-19.0, N70, 5 3/4" | ⑨ PORTLAND CEMENT CONCRETE SIDEWALK, 5" |
| ④ AGGREGATE BASE COURSE, TYPE A, 5.5" | ⑩ PORTLAND CEMENT CONCRETE SIDEWALK, 5", SPECIAL |
| ⑤ AGGREGATE BASE COURSE, TYPE A, 6.5" | ⑪ SEEDING, CLASS 1A |
| | ⑫ AGGREGATE SHOULDER, TYPE A, 6" |
| | ⑭ STONE RIPRAP, CLASS A2 (SPECIAL) |

Ⓟ6 TO Ⓟ7 = LABELS FOR PLANS SHEET TO REFERENCE PROPOSED TYPICALS

REVISIONS	
NAME	DATE

CITY OF DANVILLE, ILLINOIS
 WINTER AVENUE RECONSTRUCTION
 PROPOSED TYPICAL SECTIONS
 P6-P7
 WINTER AVENUE

SCALE: NTS
 DRAWN BY: NIL
 DATE: 12/21/06
 CHECKED BY: MBF

F.A.U. RTE.	SECTION	COUNTY	TOTAL SHEETS	SHEET NO.
6998	99-00209-01-PV	VERMILION	296	14
STA.		TO STA.		
FED. ROAD DIST. NO. ILLINOIS		FED. AID PROJECT-		

CONTRACT NO.: 91358

PLAN	SURVEYED	DATE
	PLOTTED	
	CHECKED	
	BY	
	NOTE BOOK	
	REF. OF WAY CHECKED	
	CADD FILE NAME	
	NO.	

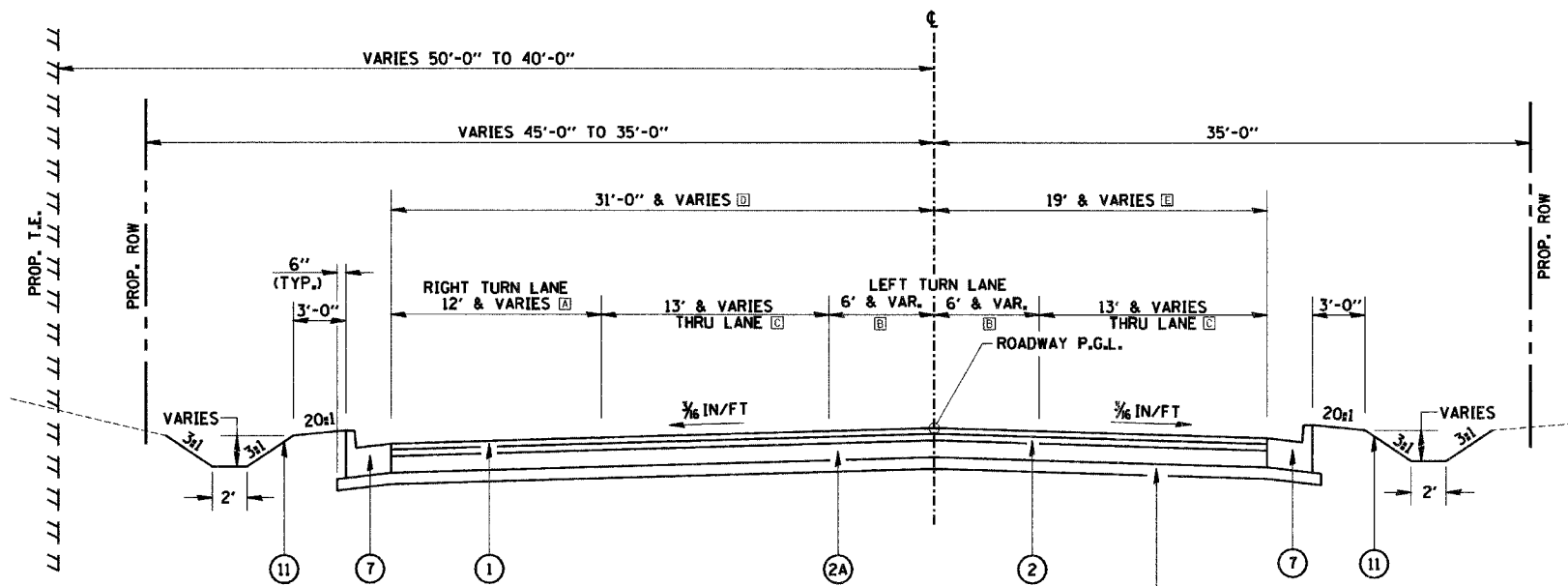

PROPOSED TYPICAL SECTION

STA. 148+11.37 TO STA. 153+13.06

(P10)

5 (STA. 148+11.37 TO STA. 149+23.09)

4 (STA. 149+23.09 TO STA. 153+13.06)

NOTES:

- Ⓐ STA. 148+11.37 TO STA. 148+74.64, VARIES 123'-4" TO 12'-0"
STA. 148+74.64 TO STA. 149+78.06, 12'-0"
STA. 149+78.06 TO STA. 150+98.06, VARIES 12'-0" TO 0'-0"
STA. 150+98.06 TO STA. 153+13.06, 0'-0"
- Ⓑ STA. 148+11.37 TO STA. 150+98.06, 6'-0"
STA. 150+98.06 TO STA. 153+08.06, VARIES 6'-0" TO 0'-0"
STA. 153+08.06 TO STA. 153+13.06, 0'-0"
- Ⓒ STA. 148+11.37 TO STA. 149+23.09, VARIES 73'-6" TO 13'-0"
STA. 149+23.09 TO STA. 150+98.06, 13'-0"
STA. 150+98.06 TO STA. 153+13.06, VARIES 13'-0" TO 12'-10 1/4"
- Ⓓ STA. 148+11.37 TO STA. 148+74.64, VARIES 142'-4" TO 31'-0"
STA. 148+74.64 TO STA. 149+78.06, 31'-0"
STA. 149+78.06 TO STA. 150+98.06, VARIES 31'-0" TO 19'-0"
STA. 150+98.06 TO STA. 153+13.06, VARIES 19'-0" TO 12'-10 1/4"
- Ⓔ STA. 148+11.37 TO STA. 149+23.09, VARIES 79'-6" TO 19'-0"
STA. 149+23.09 TO STA. 150+98.06, 19'-0"
STA. 150+98.06 TO STA. 153+13.06, VARIES 19'-0" TO 12'-10 1/4"

PROPOSED LEGEND:

- ① POLYMERIZED HOT-MIX ASPHALT SURFACE COURSE, MIX 'D', N70, 2"
- ② POLYMERIZED HOT-MIX ASPHALT BINDER COURSE, IL-19.0, N70, 2 1/4"
- ②A HOT-MIX ASPHALT BINDER COURSE, IL-19.0, N70, 5 3/4"
- ④ AGGREGATE BASE COURSE, TYPE A, 5.5"
- ⑤ AGGREGATE BASE COURSE, TYPE A, 6.5"
- ⑦ COMBINATION CONCRETE CURB & GUTTER, TYPE B-6.24
- ⑧ COMBINATION CONCRETE CURB & GUTTER, TYPE B-9.24
- ⑨ PORTLAND CEMENT CONCRETE SIDEWALK, 5"
- ⑩ PORTLAND CEMENT CONCRETE SIDEWALK, 5", SPECIAL
- ⑪ SEEDING, CLASS 1A
- ⑫ AGGREGATE SHOULDER, TYPE A, 6"
- ⑭ STONE RIPRAP, CLASS A2 (SPECIAL)

NOTES:

- Ⓔ STA. 153+13.06 TO STA. 153+43.06, VARIES 12'-10 1/4" TO 12'-0"
STA. 153+43.06 TO STA. 154+56.80, 12'-0"

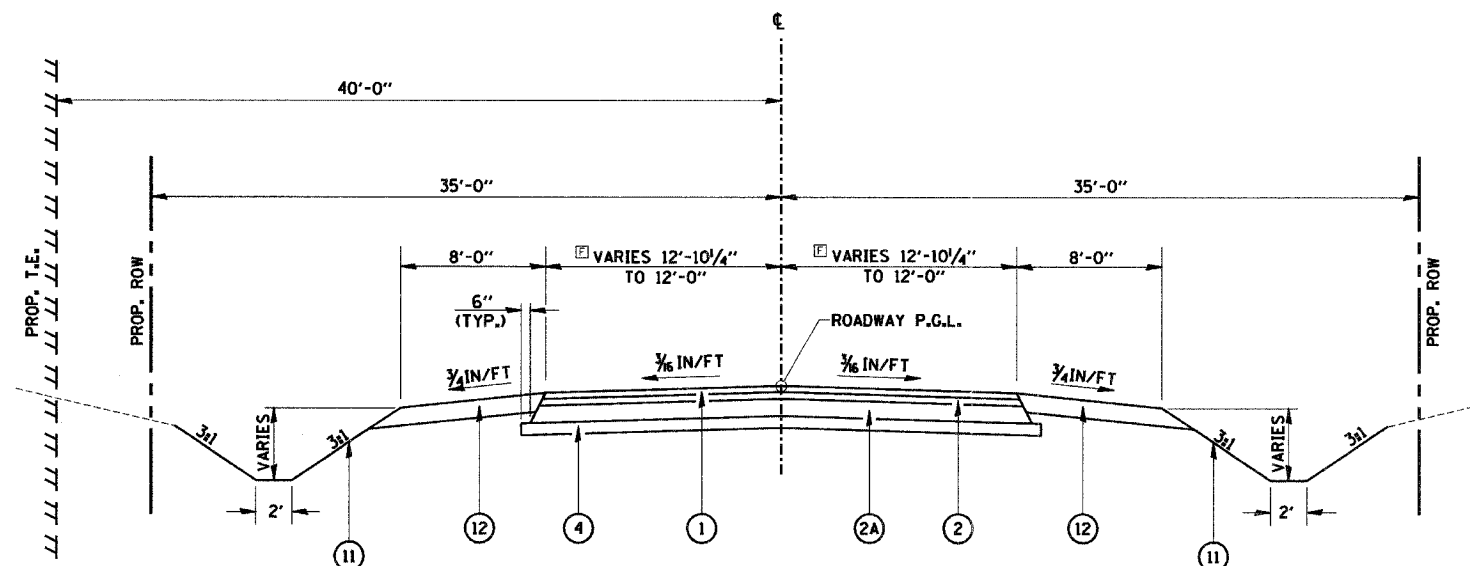

PROPOSED TYPICAL SECTION

STA. 153+13.06 TO STA. 154+56.80

(P11)

(P10) TO (P11) = LABELS FOR PLANS SHEET TO REFERENCE PROPOSED TYPICALS

REVISIONS	
NAME	DATE

CITY OF DANVILLE, ILLINOIS
WINTER AVENUE RECONSTRUCTION
 PROPOSED TYPICAL SECTIONS
 P10-P11
 WINTER AVENUE

SCALE: NTS
 DATE: 12/21/06
 DRAWN BY: NIL
 CHECKED BY: MBF

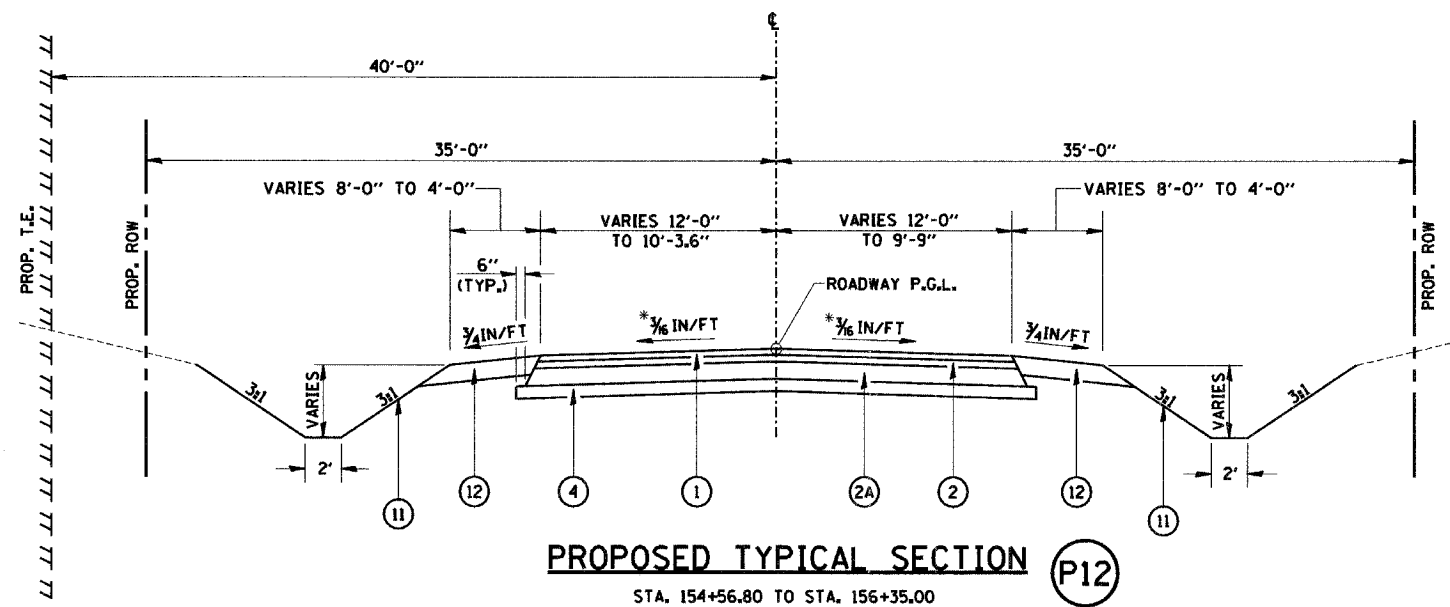

* TRANSITION PAVEMENT SLOPE TO MATCH EXISTING
 STA. 154+56.80 TO STA. 156+35.00

PROPOSED LEGEND:

- ① POLYMERIZED HOT-MIX ASPHALT SURFACE COURSE, MIX "D", N70, 2"
- ② POLYMERIZED HOT-MIX ASPHALT BINDER COURSE, IL-19.0, N70, 2 1/4"
- ②A HOT-MIX ASPHALT BINDER COURSE, IL-19.0, N70, 5 3/4"
- ④ AGGREGATE BASE COURSE, TYPE A, 5.5"
- ⑤ AGGREGATE BASE COURSE, TYPE A, 6.5"
- ⑦ COMBINATION CONCRETE CURB & GUTTER, TYPE B-6.24
- ⑧ COMBINATION CONCRETE CURB & GUTTER, TYPE B-9.24
- ⑨ PORTLAND CEMENT CONCRETE SIDEWALK, 5"
- ⑩ PORTLAND CEMENT CONCRETE SIDEWALK, 5", SPECIAL
- ⑪ SEEDING, CLASS 1A
- ⑫ AGGREGATE SHOULDER, TYPE A, 6"
- ⑭ STONE RIPRAP, CLASS A2 (SPECIAL)

Ⓟ = LABEL FOR PLANS SHEET TO REFERENCE PROPOSED TYPICALS

REVISIONS	
NAME	DATE

CITY OF DANVILLE, ILLINOIS
 WINTER AVENUE RECONSTRUCTION
 PROPOSED TYPICAL SECTIONS
 P12
 WINTER AVENUE

SCALE: NTS
 DATE: 12/21/06
 DRAWN BY: NIL
 CHECKED BY: MBF

PLAN	SURVEYED	DATE
NOTE BOOK	DESIGNED	BY
NO.	PLANNED	
	CHECKED	
	BY	
	DATE	
	FILE NAME	

F.A.D. RTE.	SECTION	COUNTY	TOTAL SHEETS	SHEET NO.
6998	99-00209-01-PV	VERMILION	296	17
STA.	TO STA.			
FED. ROAD DIST. NO. ILLINOIS	FED. AID PROJECT-			
CONTRACT NO.: 91358				

PLAN	SURVEYED	BY	DATE
	NOTED		
	DESIGNED		
	CHECKED		
	IN CHARGE		
	DATE		

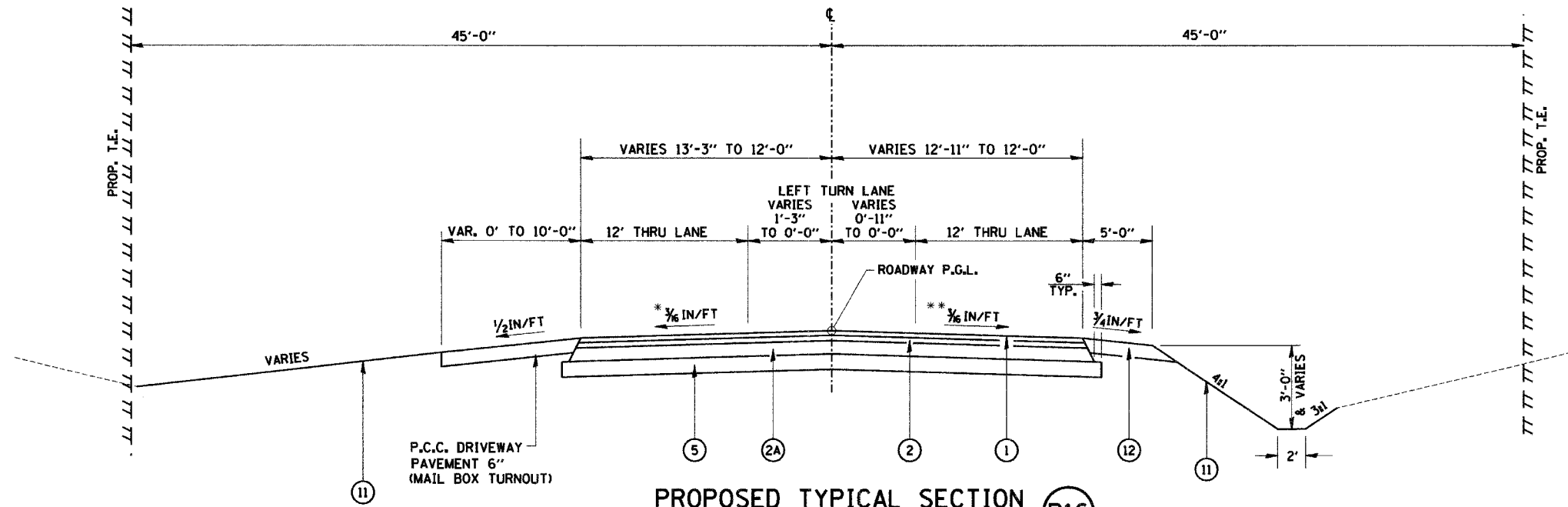

PROPOSED TYPICAL SECTION P16
 STA. 68+39.82 TO STA. 69+02.93 (LT)
 STA. 68+68.36 TO STA. 69+02.93 (RT)

* TRANSITION PAVEMENT SLOPE TO MATCH EXISTING
 STA. 68+52.93 TO STA. 69+02.93
 ** TRANSITION PAVEMENT SLOPE TO MATCH EXISTING
 STA. 68+68+36 TO STA. 69+02.93

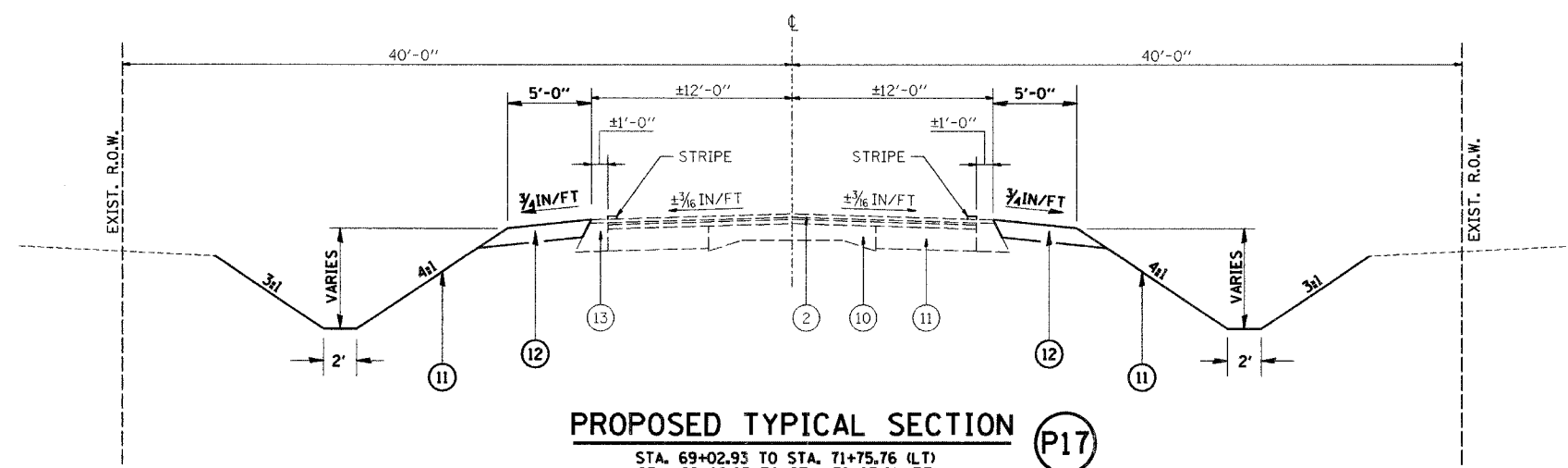

PROPOSED TYPICAL SECTION P17
 STA. 69+02.93 TO STA. 71+75.76 (LT)
 STA. 69+02.93 TO STA. 72+95.61 (RT)

PROPOSED LEGEND:

- ① POLYMERIZED HOT-MIX ASPHALT SURFACE COURSE, MIX "D", N70, 2"
- ② POLYMERIZED HOT-MIX ASPHALT BINDER COURSE, IL-19.0, N70, 2 1/4"
- ②A HOT-MIX ASPHALT BINDER COURSE, IL-19.0, N70, 5 3/4"
- ④ AGGREGATE BASE COURSE, TYPE A, 5.5"
- ⑤ AGGREGATE BASE COURSE, TYPE A, 6.5"
- ⑦ COMBINATION CONCRETE CURB & GUTTER, TYPE B-6.24
- ⑧ COMBINATION CONCRETE CURB & GUTTER, TYPE B-9.24
- ⑨ PORTLAND CEMENT CONCRETE SIDEWALK, 5"
- ⑩ PORTLAND CEMENT CONCRETE SIDEWALK, 5", SPECIAL
- ⑪ SEEDING, CLASS 1A
- ⑫ AGGREGATE SHOULDER, TYPE A, 6"
- ⑭ STONE RIPRAP, CLASS A2 (SPECIAL)

EXISTING LEGEND:

- ① EX. GROUND LINE
- ② EX. BIT. SURFACE, 4"
- ③ EX. O&C SURFACE, 1 1/2"
- ④ EX. O&C SURFACE, 2"
- ⑤ EX. O&C SURFACE, 4"
- ⑥ EX. AGG. BASE COURSE, 4"
- ⑦ EX. AGG. BASE COURSE, 6"
- ⑧ EX. COMB. C&G, TYPE B-6.12
- ⑨ EX. P.C.C. SIDEWALK, 5"
- ⑩ EX. P.C.C. PAVEMENT, 9-6-9
- ⑪ EX. P.C.C. BASE COURSE, 8"
- ⑫ EX. BIT. BASE COURSE, 9 1/2"
- ⑬ EX. BIT. SHOULDER, 6"
- ⑭ EX. AGG. SHOULDER, TYPE B
- ⑮ EX. CONC. DECK BEAMS 36"x27"
- ⑯ EX. ABUTMENT
- ⑰ EX. STEEL PLATE BEAM GUARDRAIL

① P16 TO ① P17 = LABELS FOR PLANS SHEET TO REFERENCE PROPOSED TYPICALS

REVISIONS	
NAME	DATE

CITY OF DANVILLE, ILLINOIS
 WINTER AVENUE RECONSTRUCTION
 PROPOSED TYPICAL SECTIONS
 P16-P17
 BOWMAN AVENUE
 SCALE: NTS
 DATE: 12/21/06
 DRAWN BY: NIL
 CHECKED BY: MBF

District 5 General Notes

F.A.U. RTE.	SECTION	COUNTY	TOTAL SHEETS	SHEET NO.
6998	99-00209-01-PV	VERMILION	296	19
STA. N/A		TO STA. N/A		
FED. ROAD DIST. NO. ILLINOIS			FED. AID PROJECT-	

CONTRACT NO.: 91358

G.N. -100
ENGLISH UNITS OF MEASUREMENT SHALL GOVERN OVER AND SUPERSEDE ANY METRIC UNITS SHOWN IN THIS CONTRACT. WHERE INCLUDED, METRIC UNITS ARE FOR INFORMATION ONLY.

G.N. -107.12
THE NAME, ADDRESS AND TELEPHONE NUMBER OF THE LOCAL RAILROAD CONTACT IS:

Mr. Gale Free
Roadmaster
CSX Transportation
564 CSX Lane
Danville, IL 61834
217-442-0126

SPECIAL ATTENTION IS CALLED TO ARTICLE 107.12 REGARDING RAILROAD FLAGGERS. THE NAME, ADDRESS AND TELEPHONE NUMBER OF THE RAILROAD FLAGGER CONTACT IS:

David Clifford
CSX Transportation
1700 West 167th Street
Calumet City, IL 60409
708-832-2170

G.N. -107.31
UTILITY LINES WERE PLOTTED FROM INFORMATION FURNISHED BY THE VARIOUS UTILITY COMPANIES INVOLVED (QUALITY LEVEL C &/ OR QUALITY LEVEL D) AND THE ACCURACY SHOULD BE CONSIDERED APPROXIMATE ONLY.

UTILITY COMPANIES MAY BE ADJUSTING THEIR FACILITIES DURING CONSTRUCTION. THE CONTRACTOR SHALL COOPERATE WITH THESE ORGANIZATIONS WHILE THESE ADJUSTMENTS ARE BEING PERFORMED. J.U.L.I.E. - JOINT UTILITY LOCATION INFORMATION FOR EXCAVATORS SYSTEM (800)892-0123.

G.N. -201
TREES THAT INTERFERE WITH THE CONSTRUCTION OPERATIONS SHALL BE REMOVED AS DIRECTED BY THE ENGINEER. ANY TREE DUE TO ITS LOCATION AND DEEMED SUITABLE FOR SAVING BY THE ENGINEER SHALL BE PROTECTED DURING CLEARING AND SUBSEQUENT CONSTRUCTION OPERATIONS.

G.N. -202
GRADING SHALL BE DONE BY HAND AROUND LIGHT POLES, UTILITY POLES, SIGN POSTS, SHRUBS, TREES OR OTHER NATURAL OR MAN-MADE OBJECTS WHERE SHALLOW FILLS OR CUTS ARE ADJACENT TO THE ITEMS. IT IS THE INTENT THAT THE LIMITS OF CONSTRUCTION BE SUCH AS TO PRESERVE IN THE ORIGINAL STATE AS MUCH AREA OF TEMPORARY EASEMENTS AS POSSIBLE. THE DECISION AS TO ITEMS TO REMAIN IN PLACE SHALL BE AS DIRECTED BY THE ENGINEER.

THIS WORK WILL NOT BE PAID FOR SEPARATELY, BUT SHALL BE CONSIDERED INCLUDED IN THE CONTRACT UNIT PRICE PER CUBIC YARD FOR EARTH EXCAVATION AND NO ADDITIONAL COMPENSATION WILL BE ALLOWED.

G.N. -250C (SPL)
SEEDING, CLASS 7 AND MULCH, METHOD 1 IS INCLUDED IN THIS CONTRACT TO SEED NEW EARTH SHOULDERS DURING TIME PERIODS WHEN PERMANENT SEEDING IS NOT ALLOWED. SOME OR ALL OF THE CLASS 7 SEEDING AND MULCH WILL BE DELETED IF IT IS POSSIBLE TO PLACE PERMANENT SEEDING ON EARTH SHOULDERS AT THE TIME OF THEIR COMPLETION.

G.N. -281
THE RIPRAP GRADATION SHALL BE IN ACCORDANCE WITH THE GRADATION SPECIFIED IN THE PLANS OR, WITH APPROVAL OF THE ENGINEER, A RIPRAP GRADATION MEETING A D50 GREATER THAN OR EQUAL TO 0.5'. D50 IS DEFINED AS THE MEAN ROCK SIZE AS DESCRIBED IN THE FHWA HYDRAULIC ENGINEERING CIRCULARS (HEC 11, HEC 14 AND HEC 15).

IF GRAVEL IS USED FOR THE BEDDING MATERIAL UNDER RIPRAP, THE GRAVEL SHALL BE CRUSHED AS ALLOWED UNDER ARTICLE 1005.01.

G.N. -406.05B
ALL LEVELING BINDER OR BINDER SHALL BE GIVEN A FOG COAT OF PRIME BEFORE THE SURFACE COURSE IS PLACED WHEN DIRECTED BY THE ENGINEER.

THE FOG COAT WILL BE PAID FOR AT THE CONTRACT UNIT PRICE PER GALLON FOR BITUMINOUS MATERIAL (PRIME COAT) AND NO ADDITIONAL COMPENSATION WILL BE ALLOWED.

G.N. -406H

MIXTURE REQUIREMENTS

THE FOLLOWING MIXTURE REQUIREMENTS ARE APPLICABLE FOR THIS PROJECT:

LOCATION(S):	WINTER / BOWMAN	WINTER / BOWMAN	WINTER / BOWMAN	WINTER / BOWMAN
MIXTURE USE(S):	2" POLYMER SURFACE	TOP 2 1/4" POLYMER BINDER	BOTTOM 5 3/4" BINDER	INCIDENTAL
AC/PG:	SBS PG 64-28	SBS PG 64-28	PG 64-22	PG 64-22
RAP % : (MAX)	10%	10%	15% / 25% *	10%
DESIGN AIR VOIDS:	4.0% @ N _{des} = 70	4.0% @ N _{des} = 70	4.0% @ N _{des} = 70	4.0% @ N _{des} = 70
MIXTURE COMPOSITION (GRADATION MIXTURE):	IL-9.5	IL-19.0	IL-19.0	IL-9.5
FRICTION AGGREGATE:	MIX D	N.A.	N.A.	MIX C

* MAX. RAP % IF 3/8" RAP IS UTILIZED

G.N. -542
BEFORE ORDERING PIPE CULVERTS, THE CONTRACTOR SHALL CONSULT THE ENGINEER FOR THE EXACT LENGTHS.

G.N. -542.07
AT LOCATIONS WHERE END SECTIONS ARE SPECIFIED, CAST-IN-PLACE CONCRETE HEADWALLS WILL NOT BE ALLOWED.

G.N. -542B
ALL THE ENTRANCE CULVERTS LENGTHS SHOWN IN THE PLANS WERE CALCULATED WITH THE ASSUMPTION THAT METAL PIPES AND METAL END SECTIONS WOULD BE USED.

G.N. -550
BEFORE ORDERING STORM SEWERS, THE CONTRACTOR SHALL CONSULT THE ENGINEER FOR THE EXACT LENGTHS.

G.N. -631
IF THE CONTRACTOR ELECTS TO USE THE ALTERNATE MOUNTING METHOD OF THRU DRILLING THE MOUNTING HOLES FOR THE TRAFFIC BARRIER TERMINALS, TYPE 6, THE HOLES SHALL BE DRILLED USING A CORE DRILL. A HAMMER DRILL WILL NOT BE ALLOWED.

G.N. -1004.01
COARSE AGGREGATE GRADATION CA-10 MAY BE USED WHENEVER COARSE AGGREGATE CA-6 IS SPECIFIED IN THE STANDARD SPECIFICATIONS.

REVISIONS		CITY OF DANVILLE, ILLINOIS WINTER AVENUE RECONSTRUCTION
NAME	DATE	
		LIST OF STANDARDS, GENERAL NOTES & COMMITMENTS
SCALE: NTS		DATE: 12/21/06
DRAWN BY: MBF		CHECKED BY: SMK

DATE	BY	REVISIONS	CHECKED	DATE

SUMMARY OF QUANTITIES

F.A.J. RTE.	SECTION	COUNTY	TOTAL SHEETS	SHEET NO.
6998	99-00209-01-PV	VERMILION	296	20
STA.		TO STA.		
FED. ROAD DIST. NO.		ILLINOIS		
FED. AID PROJECT-		CONTRACT NO.: 91358		

PLAN SURVEYED BY DATE
 NOTE BOOK NO.
 PLAN NO.
 CHECKED BY DATE
 REVISIONS
 DATE
 DRAWN BY: MBF
 CHECKED BY: SMK

CODE NUMBER	ITEM	UNIT	TOTAL QUANTITY	MINOR ARTERIAL ROADWAY FEDERAL 1000-2A	BRIDGE S.N. 092-6039 GCPF FEDERAL X631-2A
20100110	TREE REMOVAL (6 TO 15 UNITS DIAMETER)	UNIT	89	89	
20100210	TREE REMOVAL (OVER 15 UNITS DIAMETER)	UNIT	40	40	
20100500	TREE REMOVAL, ACRES	ACRES	0.5	0.5	
20101100	TREE TRUNK PROTECTION	EACH	11	11	
20200100	EARTH EXCAVATION	CU YD	11579	7729	3850
20400800	FURNISHED EXCAVATION	CU YD	58	58	
20700220	POROUS GRANULAR EMBANKMENT	CU YD	148		148
20800150	TRENCH BACKFILL	CU YD	1336	1319.7	16.3
25000110	SEEDING, CLASS 1A	ACRE	3.5	2.75	0.75
25000350	SEEDING, CLASS 7	ACRE	3.5	2.75	0.75
25000400	NITROGEN FERTILIZER NUTRIENT	POUND	307	245	62
25000500	PHOSPHORUS FERTILIZER NUTRIENT	POUND	307	245	62
25000600	POTASSIUM FERTILIZER NUTRIENT	POUND	307	245	62
25100105	MULCH, METHOD 1	ACRE	3.5	2.75	0.75
25100115	MULCH, METHOD 2	ACRE	2.5	2.25	0.25
25100630	EROSION CONTROL BLANKET	SO YD	3743	2242	1501
28000200	EARTH EXCAVATION FOR EROSION CONTROL	CU YD	28.2	28.2	
28000250	TEMPORARY EROSION CONTROL SEEDING	POUND	355	290	65
28000300	TEMPORARY DITCH CHECKS	EACH	43	43	
28000400	PERIMETER EROSION BARRIER	FOOT	3630	2678	952
28000500	INLET AND PIPE PROTECTION	EACH	27	26	1
28000510	INLET FILTERS	EACH	68	60	8
28100105	STONE RIPRAP, CLASS A3	SO YD	7		7
28200200	FILTER FABRIC	SO YD	274	266.9	7.1
28300100	FIBER MAT	SO YD	183	183	

CODE NUMBER	ITEM	UNIT	TOTAL QUANTITY	MINOR ARTERIAL ROADWAY FEDERAL 1000-2A	BRIDGE S.N. 092-6039 GCPF FEDERAL X631-2A
35100200	AGGREGATE BASE COURSE, TYPE A	CU YD	2678	2500	178
35101500	AGGREGATE BASE COURSE, TYPE B	CU YD	25	25	
40200800	AGGREGATE SURFACE COURSE, TYPE B	TON	62	56	6
40600100	BITUMINOUS MATERIALS (PRIME COAT)	GALLON	7000	6529.0	471
40600300	AGGREGATE (PRIME COAT)	TON	28	26.1	1.9
40600895	CONSTRUCTING TEST STRIP	EACH	1	0.9	0.1
40603085	HOT-MIX ASPHALT BINDER COURSE, IL-19.0, N70	TON	4511	4208	303
40603235	POLYMERIZED HOT-MIX ASPHALT BINDER COURSE, IL-19.0, N70	TON	1762	1643.3	118.7
40603310	HOT-MIX ASPHALT SURFACE COURSE, MIX "C", N50	TON	62		62
40603540	POLYMERIZED HOT-MIX ASPHALT SURFACE COURSE, MIX "D", N70	TON	1565	1459	106
40800010	BITUMINOUS MATERIALS (PRIME COAT)	GALLON	38	38	
40800050	INCIDENTAL HOT-MIX ASPHALT SURFACING	TON	19	19	
42001300	PROTECTIVE COAT	SO YD	2229	1986.5	242.5
42300200	PORTLAND CEMENT CONCRETE DRIVEWAY PAVEMENT, 6 INCH	SO YD	875	845.4	29.6
42400200	PORTLAND CEMENT CONCRETE SIDEWALK 5 INCH	SO FT	15925	12935	2990
42400430	PORTLAND CEMENT CONCRETE SIDEWALK 5 INCH, SPECIAL	SO FT	2021	1387	634
44000100	PAVEMENT REMOVAL	SO YD	11257	10484	773
44000200	DRIVEWAY PAVEMENT REMOVAL	SO YD	704	704	
44000500	COMBINATION CURB AND GUTTER REMOVAL	FOOT	663	663	
44000600	SIDEWALK REMOVAL	SO FT	366	366	
48100100	AGGREGATE SHOULDERS, TYPE A	TON	317	317	
50100100	REMOVAL OF EXISTING STRUCTURES	EACH	1		1
50102400	CONCRETE REMOVAL	CU YD	46.9		46.9
50105220	PIPE CULVERT REMOVAL	FOOT	529	529	
50105225	PIPE CULVERT REMOVAL (SPECIAL)	FOOT	6	6	

REVISIONS		CITY OF DANVILLE, ILLINOIS	
NAME	DATE	WINTER AVENUE RECONSTRUCTION	
		SUMMARY OF QUANTITIES	
		SCALE: DATE: 12/21/06	
		DRAWN BY: MBF CHECKED BY: SMK	

SUMMARY OF QUANTITIES

F.A.D. RTE.	SECTION	COUNTY	TOTAL SHEETS	SHEET NO.
6998	99-00209-01-PV	VERMILION	296	21
STA.		TO STA.		
FED. ROAD DIST. NO. ILLINOIS		FED. AID PROJECT-		
CONTRACT NO.: 91358				

PLAN SURVEYED BY DATE
 DRAWN BY DATE
 CHECKED BY DATE
 IN CHARGE DATE
 NO.

CODE NUMBER	ITEM	UNIT	TOTAL QUANTITY	MINOR ARTERIAL ROADWAY FEDERAL 1000-2A	BRIDGE S.N. 092-6039 GCPF FEDERAL X631-2A
50200100	STRUCTURE EXCAVATION	CU YD	784.8		784.8
50300225	CONCRETE STRUCTURES	CU YD	242.1	1.7	240.4
50300255	CONCRETE SUPERSTRUCTURE	CU YD	41		41
50300300	PROTECTIVE COAT	SQ YD	36	12	24
50500105	FURNISHING AND ERECTING STRUCTURAL STEEL	L SUM	1		1
50800205	REINFORCEMENT BARS, EPOXY COATED	POUND	214200	170	214030
50800515	BAR SPLICERS	EACH	146		146
50901720	BICYCLE RAILING	FOOT	54.8	19.3	35.5
50901725	BICYCLE RAILING, SPECIAL	FOOT	83.1	83.1	
50901760	PIPE HANDRAIL	FOOT	284		284
51100100	SLOPE WALL 4 INCH	SQ YD	484		484
51500100	NAME PLATES	EACH	1		1
51603000	DRILLED SHAFT IN SOIL	CU YD	955.0		955.0
54207159	PIPE CULVERTS, TYPE 1, REINFORCED CONCRETE - ELLIPTICAL, EQUIVALENT ROUND-SIZE 24"	FOOT	17	17	
54213450	END SECTIONS 15"	EACH	12	12	
54213657	PRECAST REINFORCED CONCRETE FLARED END SECTIONS 12"	EACH	1		1
54214503	PRECAST REINFORCED CONCRETE FLARED END SECTIONS, EQUIVALENT ROUND-SIZE 18"	EACH	2	2	
54214719	PRECAST REINFORCED CONCRETE FLARED END SECTIONS - ELLIPTICAL, EQUIVALENT ROUND-SIZE 24"	EACH	2	2	
5421D015	PIPE CULVERTS, CLASS D, TYPE 1 15" (TEMPORARY)	FOOT	110	110	
54248510	CONCRETE COLLAR	CU YD	0.9	0.9	
542A5473	PIPE CULVERTS, CLASS A, TYPE 1 EQUIVALENT ROUND-SIZE 18"	FOOT	41	41	
542D0220	PIPE CULVERTS, CLASS D, TYPE 1 15"	FOOT	252	252	
55019500	STORM SEWERS, TYPE 1, REINFORCED CONCRETE CULVERT, STORM DRAIN, AND SEWER PIPE, CLASS IV 12"	FOOT	1346	1121	225

CODE NUMBER	ITEM	UNIT	TOTAL QUANTITY	MINOR ARTERIAL ROADWAY FEDERAL 1000-2A	BRIDGE S.N. 092-6039 GCPF FEDERAL X631-2A
55019600	STORM SEWERS, TYPE 1, REINFORCED CONCRETE CULVERT, STORM DRAIN, AND SEWER PIPE, CLASS IV 15"	FOOT	231	231	
55019700	STORM SEWERS, TYPE 1, REINFORCED CONCRETE CULVERT, STORM DRAIN, AND SEWER PIPE, CLASS IV 18"	FOOT	112	112	
55021600	STORM SEWERS, TYPE 2, REINFORCED CONCRETE CULVERT, STORM DRAIN, AND SEWER PIPE, CLASS III 12"	FOOT	31	31	
55021800	STORM SEWERS, TYPE 2, REINFORCED CONCRETE CULVERT, STORM DRAIN, AND SEWER PIPE, CLASS III 18"	FOOT	41	41	
55022000	STORM SEWERS, TYPE 2, REINFORCED CONCRETE CULVERT, STORM DRAIN, AND SEWER PIPE, CLASS III 24"	FOOT	44	44	
55022200	STORM SEWERS, TYPE 2, REINFORCED CONCRETE CULVERT, STORM DRAIN, AND SEWER PIPE, CLASS III 30"	FOOT	481	481	
550A2320	STORM SEWERS, RUBBER GASKET, CLASS A, TYPE 1 12"	FOOT	29	29	
550A2330	STORM SEWERS, RUBBER GASKET, CLASS A, TYPE 1 15"	FOOT	42	42	
550A2340	STORM SEWERS, RUBBER GASKET, CLASS A, TYPE 1 18"	FOOT	13	13	
550A2520	STORM SEWERS, RUBBER GASKET, CLASS A, TYPE 2 12"	FOOT	90	90	
550A2540	STORM SEWERS, RUBBER GASKET, CLASS A, TYPE 2 18"	FOOT	92	92	
55100500	STORM SEWER REMOVAL 12"	FOOT	41	41	
58000110	MEMBRANE WATERPROOFING (SPECIAL)	SQ FT	5649		5649
58700300	CONCRETE SEALER	SQ FT	1198		1198
60100945	PIPE DRAINS 12"	FOOT	56	56	
60101805	PIPE DRAINS 8" (SPECIAL)	FOOT	22		22
60109584	PIPE UNDERDRAINS FOR STRUCTURES 8"	FOOT	60		60
60218400	MANHOLES, TYPE A, 4' - DIAMETER, TYPE 1 FRAME, CLOSED LID	EACH	16	13	3
60221100	MANHOLES, TYPE A, 5' - DIAMETER, TYPE 1 FRAME, CLOSED LID	EACH	4	4	
60235700	INLETS, TYPE A, TYPE 3 FRAME AND GRATE	EACH	42	39	3
60238700	INLETS, TYPE A, WITH SPECIAL FRAME AND GRATE	EACH	5	5	
60240220	INLETS, TYPE B, TYPE 3 FRAME AND GRATE	EACH	21	16	5

REVISIONS		NAME	DATE
NO.	DESCRIPTION		

CITY OF DANVILLE, ILLINOIS

WINTER AVENUE RECONSTRUCTION

SUMMARY OF QUANTITIES

SCALE: DATE: 02/07/07

DRAWN BY: MBF CHECKED BY: SMK

SUMMARY OF QUANTITIES

F.A.U. RTE.	SECTION	COUNTY	TOTAL SHEETS	SHEET NO.
6998	99-00209-01-PV	VERMILION	296	22
STA.		TO STA.		
FED. ROAD DIST. NO. ILLINOIS		FED. AID PROJECT-		
CONTRACT NO.: 91358				

PLAN	DATE	BY	CHECKED	DATE	BY	CHECKED	DATE	BY	CHECKED	DATE

CODE NUMBER	ITEM	UNIT	TOTAL QUANTITY	MINOR ARTERIAL ROADWAY FEDERAL	BRIDGE S.N. 092-6039 GCPF FEDERAL
				I000-2A	X631-2A
60255500	MANHOLES TO BE ADJUSTED	EACH	5	5	
60257900	MANHOLES TO BE RECONSTRUCTED	EACH	1	1	
60500060	REMOVING INLETS	EACH	3	3	
60600095	CLASS SI CONCRETE (OUTLET)	CU YD	3.4	3.4	
60605000	COMBINATION CONCRETE CURB AND GUTTER, TYPE B-6.24	FOOT	6467.5	5872.3	595.2
60607400	COMBINATION CONCRETE CURB AND GUTTER, TYPE B-9.24	FOOT	99.5	42.2	57.3
60618310	CONCRETE MEDIAN SURFACE, 4 INCH (SPECIAL)	SO FT	216		216
60900515	CONCRETE THRUST BLOCKS	EACH	1		1
63301210	REMOVE AND RE-ERECT STEEL PLATE BEAM GUARD RAIL, TYPE A	FOOT	300	300	
63301990	REMOVE AND RE-ERECT TRAFFIC BARRIER TERMINAL, TYPE 1	EACH	1	1	
63302700	REMOVE AND RE-ERECT TRAFFIC BARRIER TERMINAL, TYPE 6	EACH	1	1	
67100100	MOBILIZATION	L SUM	1	0.5	0.5
70101700	TRAFFIC CONTROL AND PROTECTION	L SUM	1	0.9	0.1
70300220	TEMPORARY PAVEMENT MARKING - LINE 4"	FOOT	37548	37548	
70300280	TEMPORARY PAVEMENT MARKING - LINE 24"	FOOT	76	76	
70301000	WORK ZONE PAVEMENT MARKING REMOVAL	SO FT	8154	8154	
*78000100	THERMOPLASTIC PAVEMENT MARKING - LETTERS & SYMBOLS	SO FT	281	281	
*78000200	THERMOPLASTIC PAVEMENT MARKING - LINE 4"	FOOT	15003	14351	652
*78000400	THERMOPLASTIC PAVEMENT MARKING - LINE 6"	FOOT	840	840.0	
*78000600	THERMOPLASTIC PAVEMENT MARKING - LINE 12"	FOOT	624	624	
*78000650	THERMOPLASTIC PAVEMENT MARKING - LINE 24"	FOOT	145	145	
*78008310	POLYUREA PAVEMENT MARKING TYPE II - LINE 4"	FOOT	334	334.0	
78200405	GUARDRAIL MARKERS	EACH	5	5	
78201000	TERMINAL MARKER - DIRECT APPLIED	EACH	1	1	
78300200	RAISED REFLECTIVE PAVEMENT MARKER REMOVAL	EACH	37	37	

*SPECIALTY ITEMS

CODE NUMBER	ITEM	UNIT	TOTAL QUANTITY	MINOR ARTERIAL ROADWAY FEDERAL	BRIDGE S.N. 092-6039 GCPF FEDERAL
				I000-2A	X631-2A
*80500105	SERVICE INSTALLATION, TYPE A (MODIFIED)	EACH	1	1	
*81012500	CONDUIT IN TRENCH, 1 1/2" DIA., PVC	FOOT	33	33	
*81012600	CONDUIT IN TRENCH, 2" DIA., PVC	FOOT	85	85	
*81012700	CONDUIT IN TRENCH, 2 1/2" DIA., PVC	FOOT	20	20	
*81013100	CONDUIT IN TRENCH, 5" DIA., PVC	FOOT	4	4	
*81021570	CONDUIT, AUGERED 3" DIA., PVC	FOOT	184	184	
*81021590	CONDUIT, AUGERED 4" DIA., PVC	FOOT	96	96	
*81400100	HANDHOLE	EACH	3	3	
*81400300	DOUBLE HANDHOLE	EACH	1	1	
*81702110	ELECTRIC CABLE IN CONDUIT, 600V (XLP-TYPE USE) 1/C NO. 10	FOOT	1317	1317	
*81900200	TRENCH AND BACKFILL FOR ELECTRICAL WORK	FOOT	142	142	
*82103250	LUMINAIRE, SODIUM VAPOR, HORIZONTAL MOUNT, PHOTO-CELL CONTROL, 250 WATT	EACH	4	4	
*85700200	FULL-ACTUATED CONTROLLER AND TYPE IV CABINET	EACH	1	1	
*87301225	ELECTRIC CABLE IN CONDUIT, SIGNAL NO. 14 3C	FOOT	766	766	
*87301245	ELECTRIC CABLE IN CONDUIT, SIGNAL NO. 14 5C	FOOT	489	489	
*87301255	ELECTRIC CABLE IN CONDUIT, SIGNAL NO. 14 7C	FOOT	1727	1727	
*87301805	ELECTRIC CABLE IN CONDUIT, SERVICE, NO. 6 2C	FOOT	36	36	
*87502680	TRAFFIC SIGNAL POST, ALUMINUM 14 FT	EACH	4	4	
*87702910	STEEL COMBINATION MAST ARM ASSEMBLY AND POLE 36 FT.	EACH	1	1	
*87702920	STEEL COMBINATION MAST ARM ASSEMBLY AND POLE 38 FT.	EACH	2	2	
*87702970	STEEL COMBINATION MAST ARM ASSEMBLY AND POLE 48 FT.	EACH	1	1	
*87800100	CONCRETE FOUNDATION, TYPE A	FOOT	12	12	
*87800200	CONCRETE FOUNDATION, TYPE D	FOOT	3	3	
*87800415	CONCRETE FOUNDATION, TYPE E 36-INCH DIAMETER	FOOT	46	46	
*88030020	SIGNAL HEAD, LED, 1-FACE, 3-SECTION, MAST-ARM MOUNTED	EACH	6	6	

REVISIONS		CITY OF DANVILLE, ILLINOIS	
NAME	DATE	WINTER AVENUE RECONSTRUCTION	
		SUMMARY OF QUANTITIES	
		SCALE: DATE: 12/21/06	
		DRAWN BY: MBF CHECKED BY: SMK	

SUMMARY OF QUANTITIES

F.A.J. RTE.	SECTION	COUNTY	TOTAL SHEETS	SHEET NO.
6998	99-00209-01-PV	VERMILION	296	23
STA.		TO STA.		
FED. ROAD DIST. NO.		ILLINOIS	FED. AID PROJECT-	
CONTRACT NO.: 91358				

PLAN SURVEYED BY DATE
 PLOTTED BY DATE
 NOTE BOOK NO. OF WAY CHECKED
 CADD FILE NAME

CODE NUMBER	ITEM	UNIT	TOTAL QUANTITY	MINOR ARTERIAL ROADWAY FEDERAL I000-2A	BRIDGE S.N. 092-6039 GCPF FEDERAL X631-2A
*88030050	SIGNAL HEAD, LED, 1-FACE, 3-SECTION, BRACKET MOUNTED	EACH	2	2	
*88030100	SIGNAL HEAD, LED, 1-FACE, 5-SECTION, BRACKET MOUNTED	EACH	4	4	
*88030110	SIGNAL HEAD, LED, 1-FACE, 5-SECTION, MAST-ARM MOUNTED	EACH	4	4	
*88200100	TRAFFIC SIGNAL BACKPLATE	EACH	10	10	
X0301232	SURVEY MARKER VAULT	EACH	1	1	
*X0301576	COAXIAL CABLE IN CONDUIT	FOOT	766	766	
*X0320872	VIDEO VEHICLE DETECTION SYSTEM	EACH	1	1	
X0322054	REMOVAL OF PRECAST FLARED END SECTION	EACH	2	2	
X0323381	STORM SEWERS, (WATER MAIN REQUIREMENTS), TYPE 1 12"	FOOT	154	154	
X0323988	TEMPORARY SOIL RETENTION SYSTEM	SO FT	1637		1637
X0325348	TEMPORARY BALLAST RETAINER (INSTALLED AND REMOVED)	FOOT	142		142
X0696000	BRIDGE DRAINAGE SYSTEM	L SUM	1		1
X4021000	TEMPORARY ACCESS (PRIVATE ENTRANCE)	EACH	11	10	1
X4022000	TEMPORARY ACCESS (COMMERCIAL ENTRANCE)	EACH	7	7	
*X8730027	ELECTRIC CABLE IN CONDUIT, GROUNDING, NO. 6 1C	FOOT	548	548	
XX003437	REMOVE AND REINSTALL EXISTING PRECAST REINFORCED CONCRETE FLARED END SECTIONS	EACH	1	1	
XX004096	REMOVE AND RE-INSTALL CONCRETE FLARED END SECTIONS	EACH	1	1	
XX004782	TEMPORARY BITUMINOUS PAVEMENT	SO YD	2771	2771	
XX005630	TEMPORARY AGGREGATE SHOULDER	TON	115	115	
Z0002300	BALLAST	CU YD	95		95
Z0013798	CONSTRUCTION LAYOUT	L SUM	1	0.9	0.1
Z0048665	RAILROAD PROTECTIVE LIABILITY INSURANCE	L SUM	1		1
Z0069700	SUB-BALLAST	CU YD	34		34
XX006904	PIPE CULVERTS, TYPE 1, REINFORCED CONCRETE - ELLIPTICAL, EQUIVALENT ROUND-SIZE 24" (TEMPORARY)	FOOT	4	4	

*SPECIALTY ITEMS

CODE NUMBER	ITEM	UNIT	TOTAL QUANTITY	MINOR ARTERIAL ROADWAY FEDERAL I000-2A	BRIDGE S.N. 092-6039 GCPF FEDERAL X631-2A
XX006905	STONE RIPRAP, CLASS A2 (SPECIAL)	SO YD	267	267	
52100530	ANCHOR BOLTS, 1 1/4"	EACH	156		156

REVISIONS		CITY OF DANVILLE, ILLINOIS WINTER AVENUE RECONSTRUCTION	
NAME	DATE		
		SUMMARY OF QUANTITIES	
		SCALE:	DATE: 02/07/07
		DRAWN BY: MBF	CHECKED BY: SMK

SCHEDULE OF QUANTITIES

F.A.I. RTE.	SECTION	COUNTY	TOTAL SHEETS	SHEET NO.
6998	99-00209-01-PV	VERMILION	296	24
STA. N/A	TO STA. N/A			
FED. ROAD DIST. NO. ILLINOIS	FED. AID PROJECT-			

CONTRACT NO.: 91358

SEEDING SCHEDULE

FROM STATION	TO STATION	LT/RT	PERMANENT SEEDING						WINTER SHUTDOWN	
			SEEDING CL IA ACRE 25000110	NITROGEN FERT NUTR POUND 25000400	PHOSPHORUS FERT NUTR POUND 25000500	POTASSIUM FERT NUTR POUND 25000600	MULCH METHOD 2 ACRE 25100115	EROSION CONTR BLANKET SO YD 25100630	SEEDING CL 7 ACRE 25000350	MULCH METHOD 1 ACRE 25100105
WINTER AVENUE										
100+10	102+25	LT	0.030	2.70	2.70	2.70	0.030		0.030	0.030
100+00	102+25	RT	0.026	2.34	2.34	2.34	0.026		0.026	0.026
102+25	103+00	LT	0.022	1.98	1.98	1.98	0.022		0.022	0.022
102+25	103+00	RT	0.030	2.70	2.70	2.70	0.030		0.030	0.030
103+00	106+38	LT	0.339	30.51	30.51	30.71	0.169	824.8	0.339	0.339
103+00	106+12	RT	0.297	26.73	26.73	26.73	0.158	676.1	0.297	0.297
106+84	109+00	LT	0.054	4.86	4.86	4.86	0.054		0.054	0.054
106+39	109+00	RT	0.208	18.72	18.72	18.72	0.176	83.6	0.208	0.208
109+00	114+50	LT	0.159	14.31	14.31	14.31	0.159		0.159	0.159
109+00	114+50	RT	0.276	24.84	24.84	24.84	0.253		0.276	0.276
141+50	145+00	LT	0.071	6.39	6.39	6.39	0.071		0.071	0.071
141+50	145+00	RT	0.150	13.50	13.50	13.50	0.114		0.150	0.150
145+00	147+50	LT	0.083	7.47	7.47	7.47	0.083		0.083	0.083
145+00	147+50	RT	0.138	12.42	12.42	12.42	0.112		0.138	0.138
148+50	151+00	LT	0.091	8.19	8.19	8.19	0.072		0.091	0.091
148+50	150+83	RT	0.057	5.13	5.13	5.13	0.031		0.057	0.057
151+00	156+35	LT	0.142	12.78	12.78	12.78	0.086		0.142	0.142
151+01	156+35	RT	0.143	12.87	12.87	12.87	0.120		0.143	0.143
BOWMAN AVENUE										
57+78	60+00	LT	0.084	7.56	7.56	7.56	0.058		0.084	0.084
56+89	60+00	RT	0.088	7.92	7.92	7.92	0.064		0.088	0.088
60+00	61+40	LT	0.043	3.87	3.87	3.87	0.040		0.043	0.043
60+00	61+54	RT	0.048	4.32	4.32	4.32	0.034		0.048	0.048
62+27	63+50	LT	0.046	4.14	4.14	4.14	0.034		0.046	0.046
62+25	63+50	RT	0.056	5.04	5.04	5.04	0.043		0.056	0.056
63+50	69+50	LT	0.271	24.39	24.39	24.39	0.210		0.271	0.271
63+50	69+50	RT	0.271	24.39	24.39	24.39	0.210		0.271	0.271
69+50	71+76	LT	0.061	5.49	5.49	5.49	0.039		0.061	0.061
69+50	72+96	RT	0.122	10.98	10.98	10.98	0.098		0.122	0.122
TOTALS			3.406	306.54	306.54	306.54	2.596	*1584.5	3.406	3.406
USE			3.50	307	307	307	2.50		3.50	3.50

*PARTIAL QUANTITY

DITCH LINING SCHEDULE

FROM STATION	TO STATION	LT/RT	EROSION CONTR BLANKET SO YD 25100630	FIBER MAT SO YD 28300100
WINTER AVENUE				
107+75.00	109+00.00	RT		72.9
109+00.00	110+86.72	RT		110.4
141+50.00	142+03.18	RT	31.0	
142+47.50	145+00.00	RT	145.4	
145+00.00	147+09.68	RT	124.4	
149+19.17	151+00.00	LT	94.1	
148+50.00	150+72.14	RT	126.9	
151+00.00	151+67.07	LT	39.1	
152+06.48	152+61.63	LT	32.1	
152+99.59	156+35.00	LT	199.0	
153+12.50	154+52.50	RT	71.9	
155+47.40	156+35.00	RT	40.7	
BOWMAN AVENUE				
57+78.16	58+40.00	LT	35.4	
58+40.00	60+00.00	LT	93.3	
57+97.34	58+40.00	RT	24.4	
58+40.00	60+00.00	RT	93.3	
60+00.00	60+21.85	LT	12.7	
60+00.00	60+20.14	RT	11.7	
60+59.25	61+48.21	RT	56.2	
62+46.78	63+50.00	LT	57.6	
62+46.90	63+50.00	RT	60.9	
63+50.00	64+19.86	LT	40.8	
64+59.86	67+24.40	LT	154.3	
67+56.40	68+43.32	LT	72.7	
68+95.32	69+50.00	LT	31.4	
63+50.00	64+04.78	RT	32.0	
64+70.80	65+60.76	RT	52.4	
66+01.54	68+68.09	RT	158.8	
68+68.06	69+50.00	RT	46.9	
69+50.00	71+35.85	LT	104.7	
69+50.00	71+50.11	RT	114.5	
TOTALS			*2158.6	183.3
USE			183	

*PARTIAL QUANTITY

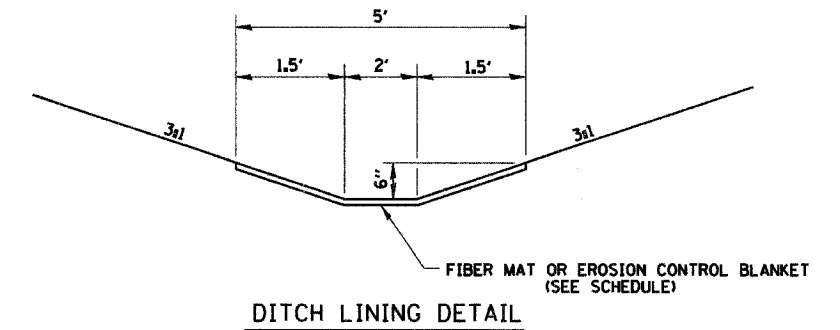

PAVEMENT SCHEDULE

FROM STATION	TO STATION	AGG BASE CSE A CU YD 35100200	BIT MATLS PR CT GALLON 40600100	AGG PR CT TON 40600300	HMA BC IL-19.0 NTO TON 40603085	P HMA BC IL-19.0 NTO TON 40603235	P HMA SC "D" NTO TON 40603540
WINTER AVENUE							
100+10.00	102+25.00	115.4	306.8	1.2	197.6	77.3	68.7
102+25.00	103+00.00	41.0	108.4	0.4	69.8	27.3	24.3
103+00.00	105+51.20	137.2	362.8	1.5	233.7	91.4	81.3
107+18.20	109+00.00	99.3	262.6	1.1	169.1	66.2	58.8
109+00.00	114+50.00	300.3	794.5	3.2	511.6	200.2	178.0
141+50.00	145+00.00	215.8	583.8	2.3	375.9	147.1	130.7
145+00.00	146+64.24	146.7	423.5	1.7	272.8	106.7	94.9
149+23.09	151+00.00	156.1	450.6	1.8	290.2	113.5	100.9
151+00.00	156+35.00	277.6	804.2	3.2	520.8	200.8	177.1
BOWMAN AVENUE							
58+40.00	60+00.00	135.5	320.0	1.3	206.1	80.6	71.7
60+00.00	63+50.00	626.3	1577.8	6.3	1016.0	397.6	353.4
63+50.00	69+02.93	427.2	1005.2	4.0	647.8	253.0	224.7
TOTALS		2678.4	7000.2	28.0	4511.4	1761.7	1564.5
USE		2678	7000	28	4511	1762	1565

NOTES:

- BITUMINOUS MATERIALS PRIME COAT QUANTITIES ARE BASED ON ONE APPLICATION OVER THE AGGREGATE BASE COURSE (0.35 GAL./SQ.YD.), ONE APPLICATION OVER THE BINDER COURSE (0.075 GAL./SQ.YD.) AND ONE APPLICATION OVER THE POLYMERIZED BINDER COURSE (0.075 GAL./SQ.YD.).
- AGGREGATE PRIME COAT QUANTITIES ARE BASED ON THE APPLICATION OF ONE LAYER OVER THE POLYMERIZED BINDER COURSE (4.0 LBS./SQ.YD.).
- AGGREGATE CONVERSION RATE = 1.8 TONS/CU YD

QUANTITIES NOT OTHERWISE SCHEDULED

LOCATION	CONSTRUC TEST STRIP EACH 40600895	MOBILIZATION L SUM 67100100	CONSTRUCTION LAYOUT L SUM 20013798	RR PROT LIABILITY INS L SUM 20048665
PROJECT LIMITS TOTALS	1	1	1	1

REVISIONS	
NAME	DATE

CITY OF DANVILLE, ILLINOIS
WINTER AVENUE RECONSTRUCTION
SCHEDULE OF QUANTITIES

SCALE: NTS
 DRAWN BY: SRS
 DATE: 12/21/06
 CHECKED BY: MBF

SCHEDULE OF QUANTITIES

F.A.D. RTE.	SECTION	COUNTY	TOTAL SHEETS	SHEET NO.
6998	99-00209-01-PV	VERMILION	296	25
STA. N/A		TO STA. N/A		
FED. ROAD DIST. NO. ILLINOIS		FED. AID PROJECT-		
CONTRACT NO.: 91358				

PLAN	DATE
SURVEYED	BY
DESIGNED	
PLANNED	
ALIGNED	
CHECKED	
RT. OF WAY CHECKED	
NOTE BOOK NO.	
ADD FILE NAME	

EARTHWORK SCHEDULE

LOCATION	EARTH EXCAVATION (CUT) (CU YD) 20200100	EXCAVATION (CUT) (ADJUSTED FOR SHRINKAGE) (CU YD)	EMBANKMENT (FILL) (CU YD)	EARTHWORK BALANCE WASTE (+) OR FURNISHED EXCAVATION (-) (CU YD) 20400800
STAGE 1				
BOWMAN AVE. - SEGMENT 1 - STA. 56+00 TO STA. 62+00	39	29	68	-39
BOWMAN AVE. - SEGMENT 2 - STA. 62+00 TO STA. 73+00	275	206	225	-19
STAGE 1 TOTALS	314	235	293	-58
STAGE 2				
WINTER AVE. - SEGMENT 2 - STA. 140+50 TO STA. 147+50	2,371	1,778	194	1,584
BOWMAN AVE. - SEGMENT 1 - STA. 56+00 TO STA. 62+00	353	265	6	259
BOWMAN AVE. - SEGMENT 2 - STA. 62+00 TO STA. 73+00	158	119	151	-32
STAGE 2 TOTALS	2,882	2,162	351	1,811
STAGE 3				
WINTER AVE. - SEGMENT 3 - STA. 148+50 TO STA. 157+00	565	424	730	-306
BOWMAN AVE. - SEGMENT 1 - STA. 56+00 TO STA. 62+00	290	218	59	159
BOWMAN AVE. - SEGMENT 2 - STA. 62+00 TO STA. 73+00	497	373	265	108
STAGE 3 TOTALS	1,352	1,015	1,054	-39
STAGE 4				
BOWMAN AVE. - SEGMENT 1 - STA. 56+00 TO STA. 62+00	69	52	105	-53
BOWMAN AVE. - SEGMENT 2 - STA. 62+00 TO STA. 73+00	222	167	245	-78
STAGE 4 TOTALS	291	219	350	-131
STAGE 5				
WINTER AVE. - SEGMENT 1A - STA. 99+00 TO STA. 102+25	500	375	1	374
WINTER AVE. - SEGMENT 1B - STA. 102+25 TO STA. 105+51.20	266	200	253	-53
CSXT STRUCTURE - STA. 26+75.82 TO STA. 28+60.94	3,584	2,688	0	2,688
WINTER AVE. - SEGMENT 1C - STA. 105+51.20 TO STA. 114+50.00	2,390	1,792	359	1,433
STAGE 5 TOTALS	6,740	5,055	613	4,442
PROJECT TOTALS	11,579	8,686	2,661	6,025
USE	11,580			60

(NOTE: PER BDE MANUAL CH. 64-2.02(a), USE SHRINKAGE FACTOR = 25%)
 (NOTE: EMBANKMENT IS FOR INFORMATION ONLY & NOT A PAY ITEM)
 (NOTE: SEE CSXT STRUCTURE EARTH EXCAVATION COMPUTATIONS FOR STRUCTURE QUANTITY)

REVISIONS		CITY OF DANVILLE, ILLINOIS WINTER AVENUE RECONSTRUCTION SCHEDULE OF QUANTITIES
NAME	DATE	
SCALE: NTS		DATE: 12/21/06
DRAWN BY: SRS		CHECKED BY: MBF

F.A.U. RTE.	SECTION	COUNTY	TOTAL SHEETS	SHEET NO.
6998	99-00209-01-PV	VERMILION	296	26
STA. 95+00		TO STA. 116+50		
FED. ROAD DIST. NO. ILLINOIS		FED. AID PROJECT-		
CONTRACT NO. 91358				

LEGEND

- BB-1 - BB-4 = BRIDGE SOIL BORINGS
- SP-1 = SPECIAL BORINGS
- PDB-1 - PDB-4 = PAVEMENT DESIGN BORINGS
- TSB-1 - TSB-4 = TRAFFIC SIGNAL SOIL BORINGS
- DCB-1 = DEEP CUT BORINGS

PLAN	DATE
SURVEYED	BY
PLOTTED	BY
CHECKED	BY
NO. OF WAY CHECKED	
CADD FILE NAME	
NO.	

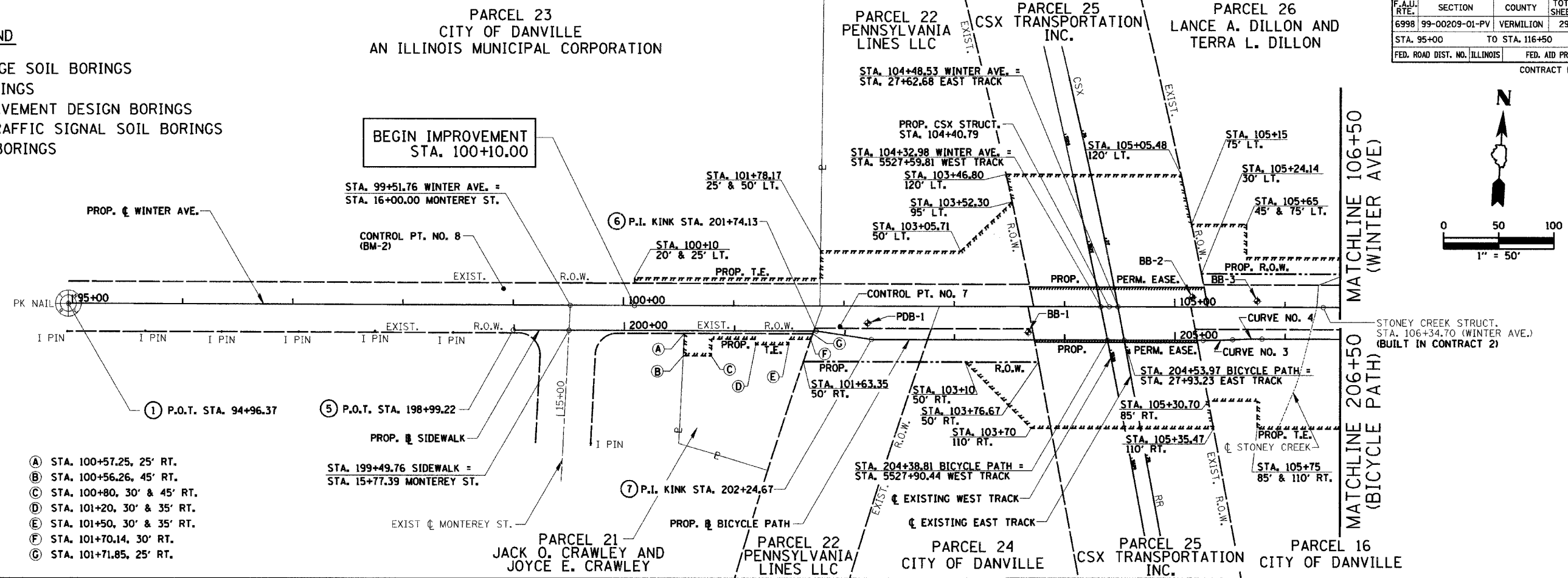

- (A) STA. 100+57.25, 25' RT.
- (B) STA. 100+56.26, 45' RT.
- (C) STA. 100+80, 30' & 45' RT.
- (D) STA. 101+20, 30' & 35' RT.
- (E) STA. 101+50, 30' & 35' RT.
- (F) STA. 101+70.14, 30' RT.
- (G) STA. 101+71.85, 25' RT.

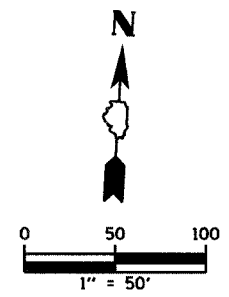

PLAN	DATE
SURVEYED	BY
PLOTTED	BY
CHECKED	BY
NO. OF WAY CHECKED	
CADD FILE NAME	
NO.	

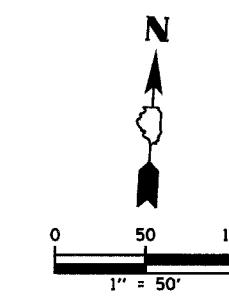
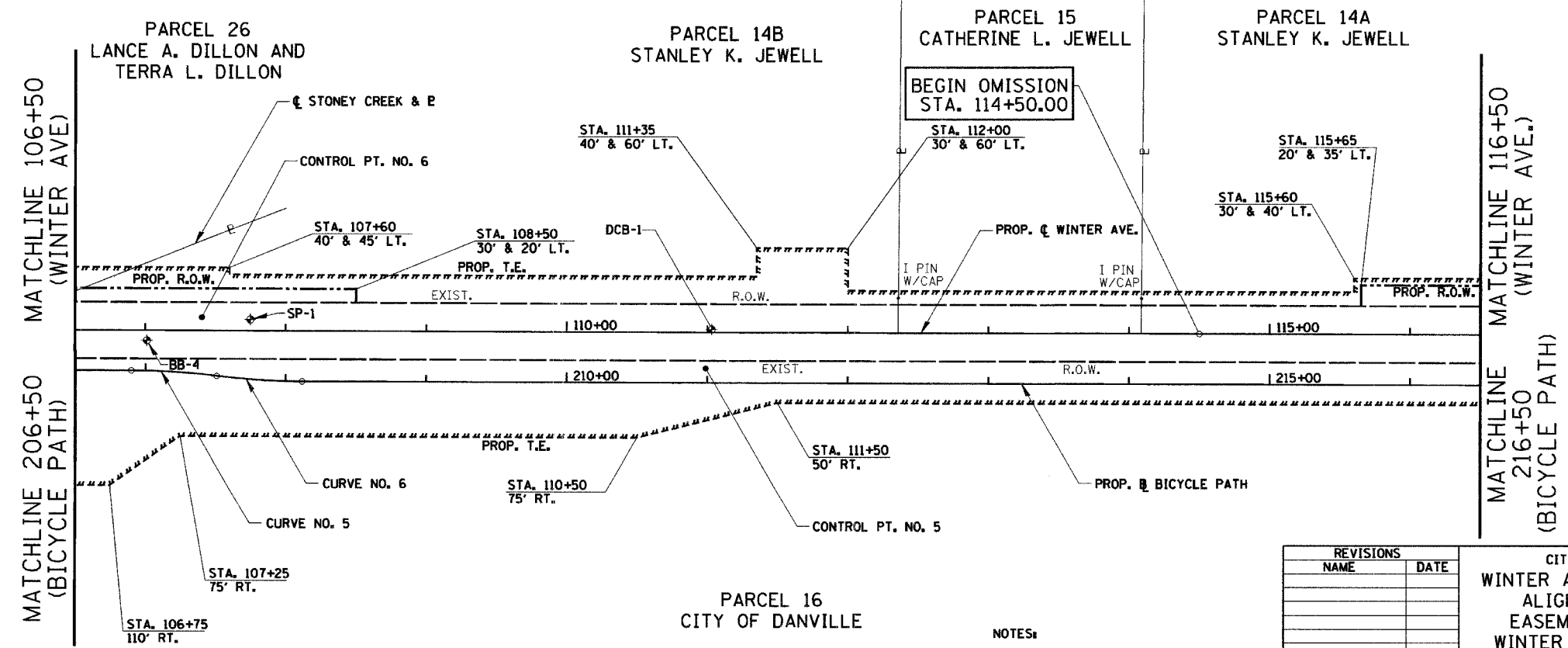

NOTES:
 SEE ATB SHEET 5 OF 6 FOR ALIGNMENT
 TIES, CONTROL POINTS & BENCHMARKS.
 SEE ATB SHEET 6 OF 6 FOR CURVE DATA.

REVISIONS	
NAME	DATE

CITY OF DANVILLE, ILLINOIS
 WINTER AVENUE RECONSTRUCTION
 ALIGNMENT, TIES, R.O.W.,
 EASEMENTS, & BENCHMARKS
 WINTER AVENUE/BICYCLE PATH
 STA. 95+00 TO STA. 116+50
 SCALE: 1" = 50'
 DATE: 12/21/06
 DRAWN BY: NIL
 CHECKED BY: SMK

F.A.U. RTE.	SECTION	COUNTY	TOTAL SHEETS	SHEET NO.
6998	99-00209-01-PV	VERMILION	296	27
STA. 116+50		TO STA. 136+50		
FED. ROAD DIST. NO. ILLINOIS		FED. AID PROJECT-		
CONTRACT NO.: 91358				

LEGEND
 BB-1 - BB-4 = BRIDGE SOIL BORINGS
 SP-1 = SPECIAL BORINGS
 PDB-1 - PDB-4 = PAVEMENT DESIGN BORINGS
 TSB-1 - TSB-4 = TRAFFIC SIGNAL SOIL BORINGS
 DCB-1 = DEEP CUT BORINGS

PLAN	SURVEYED	BY	DATE
	PLANNED		
	CHECKED		
	RT. OF WAY CHECKED		
	NO. 1		
	NO. 2		
	NO. 3		
	NO. 4		

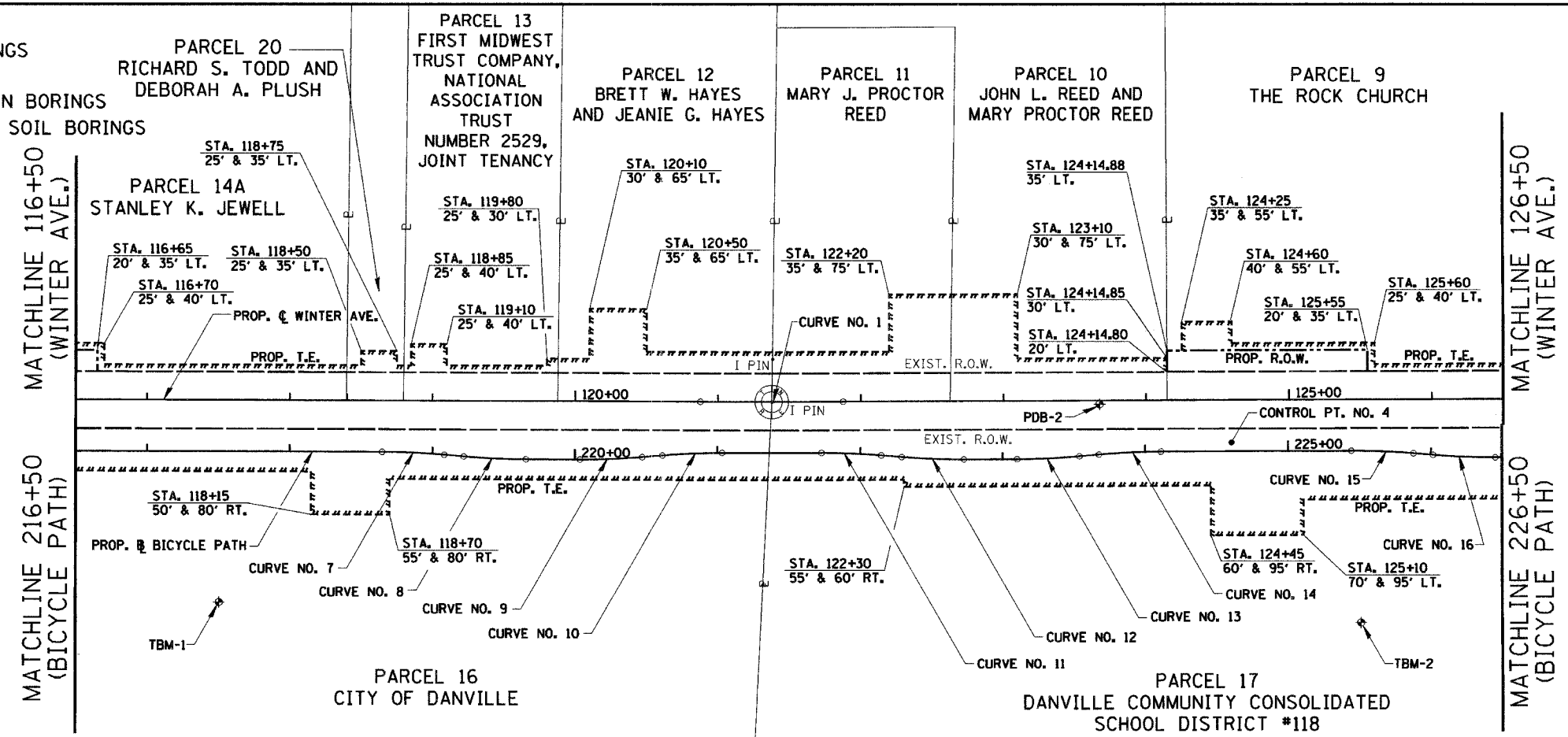

PLAN	SURVEYED	BY	DATE
	PLANNED		
	CHECKED		
	RT. OF WAY CHECKED		
	NO. 1		
	NO. 2		
	NO. 3		
	NO. 4		

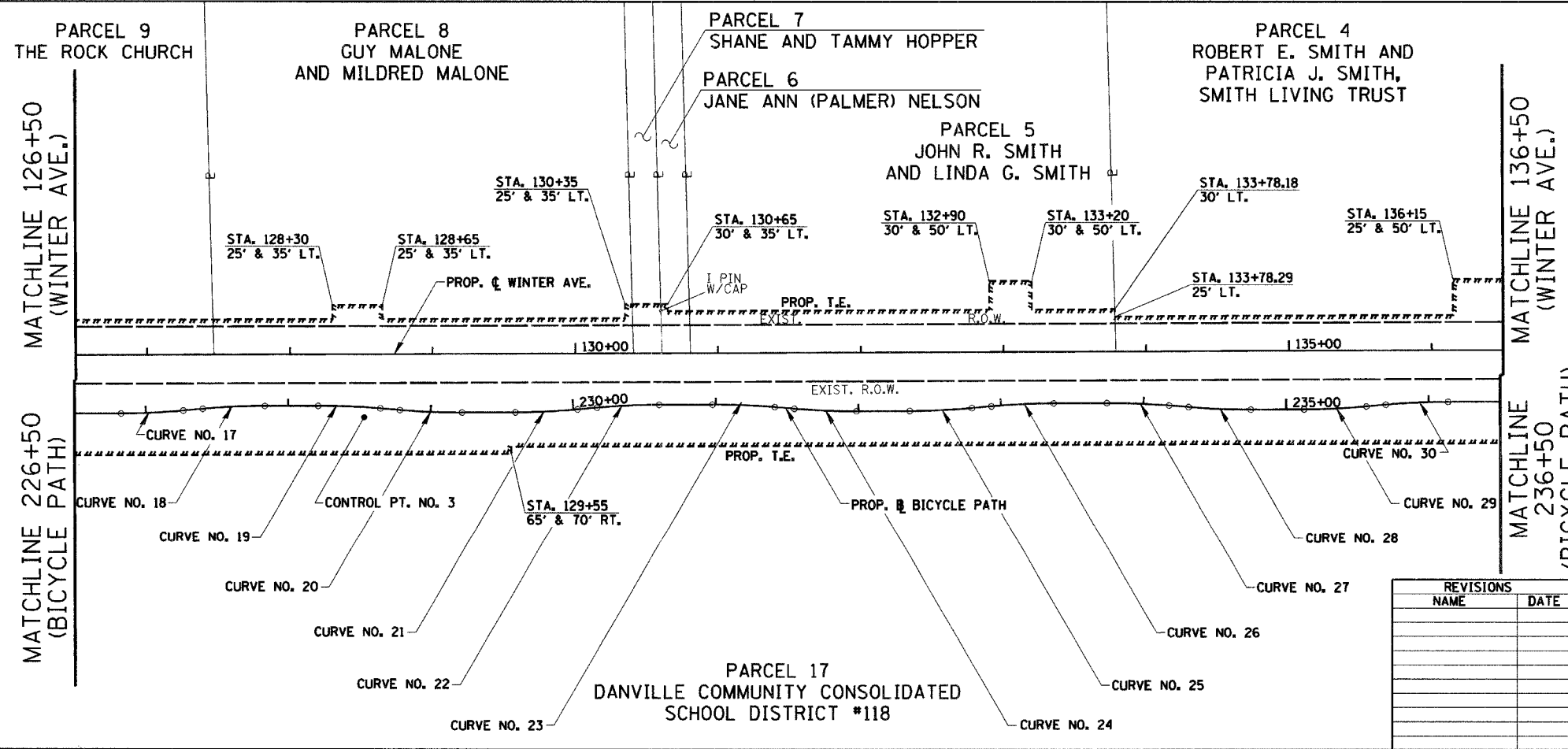

NOTES:
 SEE ATB SHEET 5 OF 6 FOR ALIGNMENT TIES, CONTROL POINTS & BENCHMARKS.
 SEE ATB SHEET 6 OF 6 FOR CURVE DATA.

ATB SHEET 2 OF 6

REVISIONS	NAME	DATE

CITY OF DANVILLE, ILLINOIS
 WINTER AVENUE RECONSTRUCTION
 ALIGNMENT, TIES, R.O.W.,
 EASEMENTS & BENCHMARKS
 WINTER AVENUE/BICYCLE PATH
 STA. 116+50 TO STA. 136+50
 SCALE: 1" = 50'
 DATE: 12/21/06
 DRAWN BY: NIL
 CHECKED BY: SMK

F.A.U. RTE.	SECTION	COUNTY	TOTAL SHEETS	SHEET NO.
6998	99-00209-01-PV	VERMILION	296	28
STA. 136+50		TO STA. 157+93.36		
FED. ROAD DIST. NO. ILLINOIS		FED. AID PROJECT-		
CONTRACT NO.: 91358				

PLAN	SURVEYED	DATE
	BY	
	NOTED	
	CHECKED	
	REVISIONS	
	NO. OF WAYS CHECKED	
	CADD FILE NAME	
	NO.	

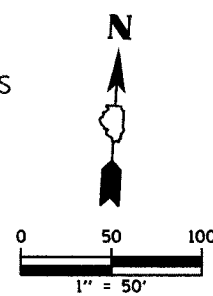
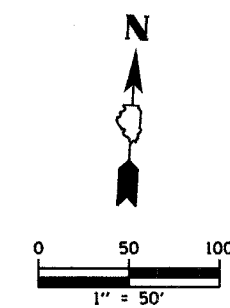

LEGEND
 BB-1 - BB-4 = BRIDGE SOIL BORINGS
 SP-1 = SPECIAL BORINGS
 PDB-1 - PDB-4 = PAVEMENT DESIGN BORINGS
 TSB-1 - TSB-4 = TRAFFIC SIGNAL SOIL BORINGS
 DCB-1 = DEEP CUT BORINGS

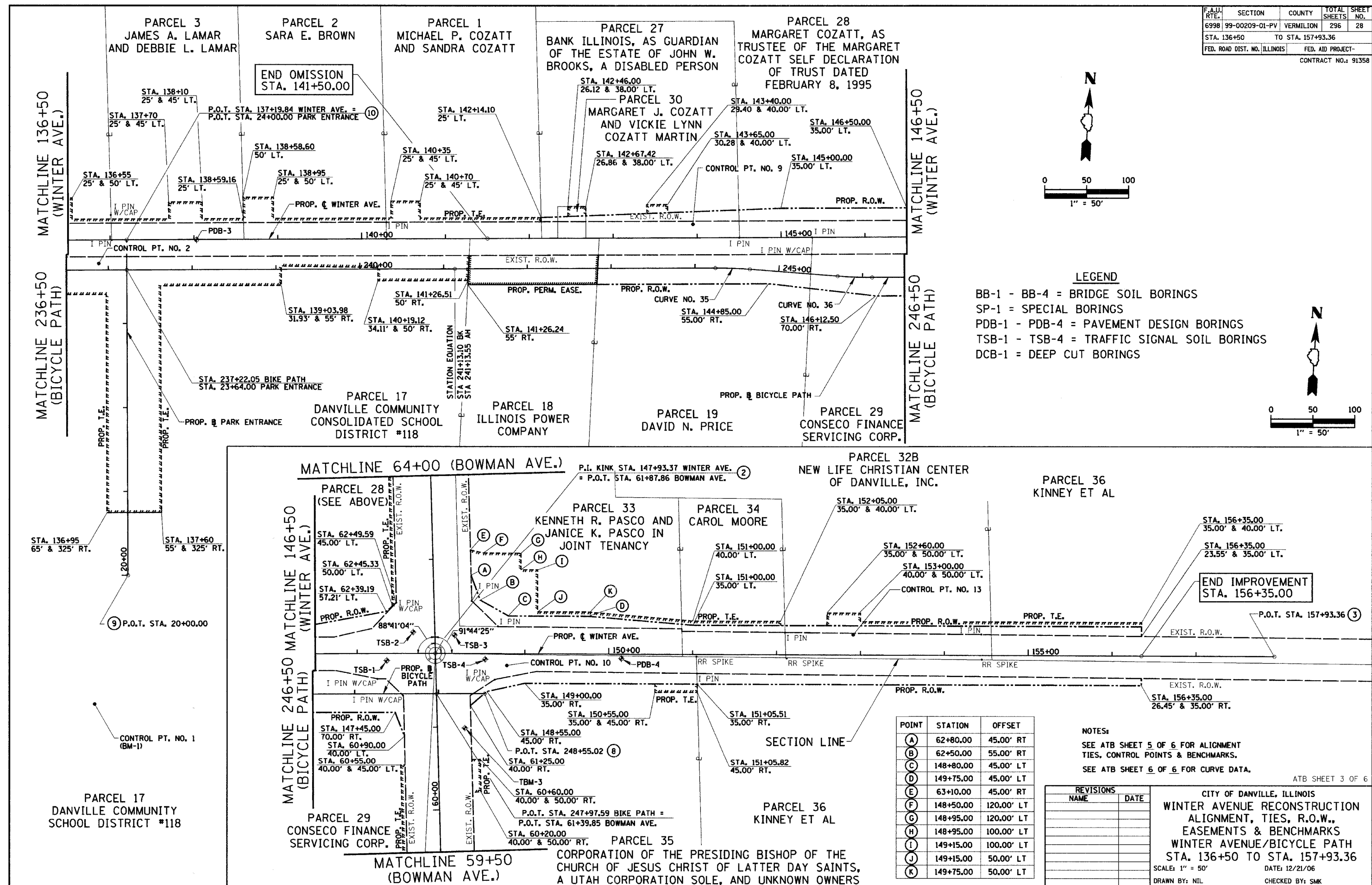

POINT	STATION	OFFSET
(A)	62+80.00	45.00' RT
(B)	62+50.00	55.00' RT
(C)	148+80.00	45.00' LT
(D)	149+75.00	45.00' LT
(E)	63+10.00	45.00' RT
(F)	148+50.00	120.00' LT
(G)	148+95.00	120.00' LT
(H)	148+95.00	100.00' LT
(I)	149+15.00	100.00' LT
(J)	149+15.00	50.00' LT
(K)	149+75.00	50.00' LT

NOTES:
 SEE ATB SHEET 5 OF 6 FOR ALIGNMENT TIES, CONTROL POINTS & BENCHMARKS.
 SEE ATB SHEET 6 OF 6 FOR CURVE DATA.

REVISIONS	DATE
NAME	

CITY OF DANVILLE, ILLINOIS
WINTER AVENUE RECONSTRUCTION ALIGNMENT, TIES, R.O.W., EASEMENTS & BENCHMARKS WINTER AVENUE/BICYCLE PATH STA. 136+50 TO STA. 157+93.36
 SCALE: 1" = 50'
 DATE: 12/21/06
 DRAWN BY: NIL
 CHECKED BY: SMK

F.A.U. RTE.	SECTION	COUNTY	TOTAL SHEETS	SHEET NO.
6998	99-00209-01-PV	VERMILION	296	29
STA. 41+80.18		TO STA. 59+50		
FED. ROAD DIST. NO. ILLINOIS		FED. AID PROJECT-		

CONTRACT NO.: 91358

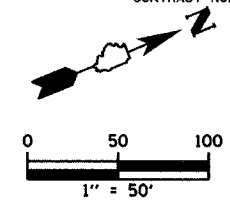

LEGEND

- BB-1 - BB-4 = BRIDGE SOIL BORINGS
- SP-1 = SPECIAL BORINGS
- PDB-1 - PDB-4 = PAVEMENT DESIGN BORINGS
- TSB-1 - TSB-4 = TRAFFIC SIGNAL SOIL BORINGS
- DCB-1 = DEEP CUT BORINGS

PLAN	SURVEYED	DATE
	BY	
	NOTED	
	CHECKED	
	PT. OF WAY CHECKED	
	CADD FILE NAME	
	NO.	

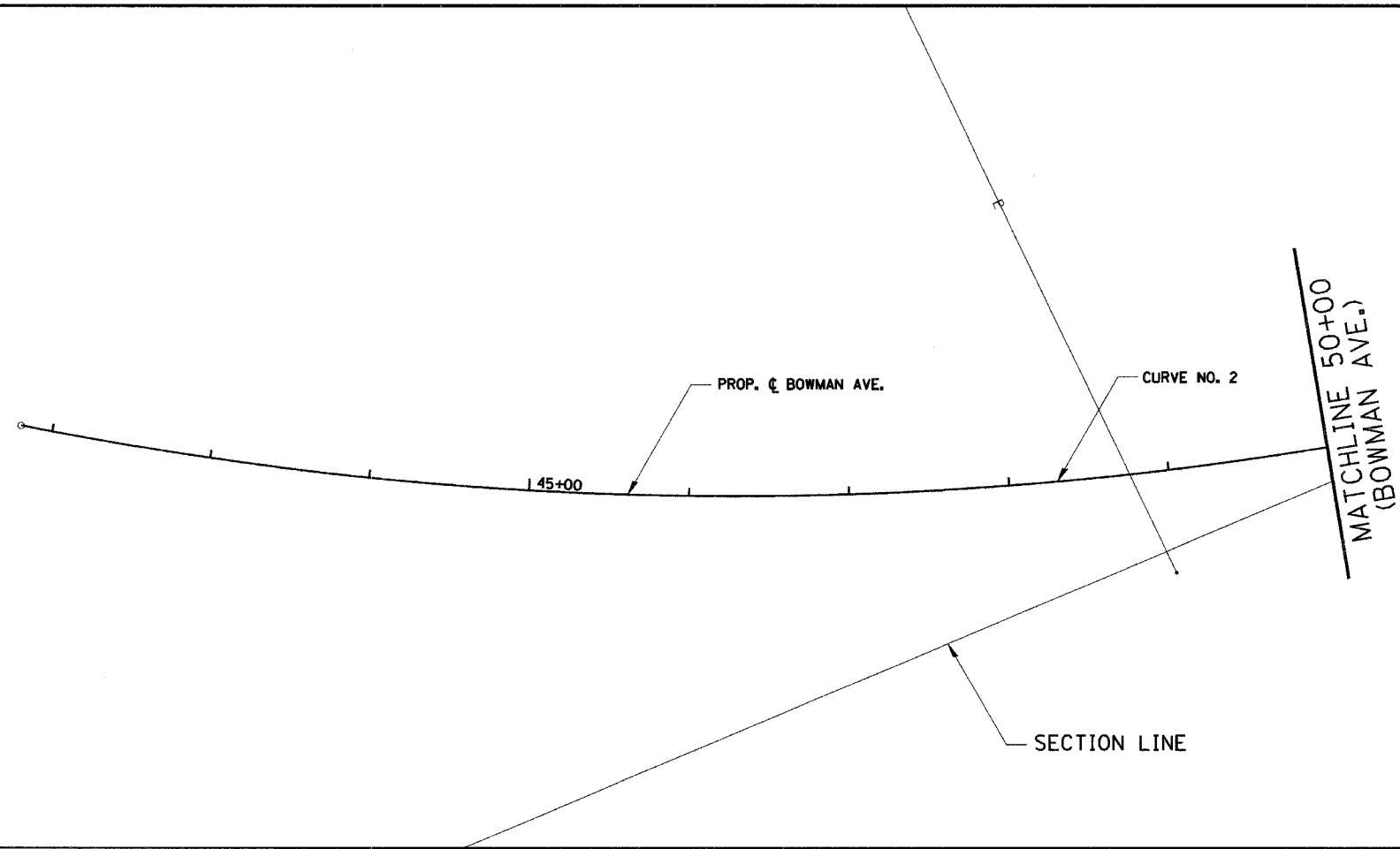

PLAN	SURVEYED	DATE
	BY	
	NOTED	
	CHECKED	
	PT. OF WAY CHECKED	
	CADD FILE NAME	
	NO.	

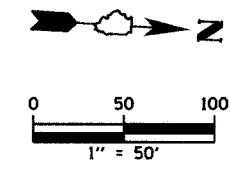
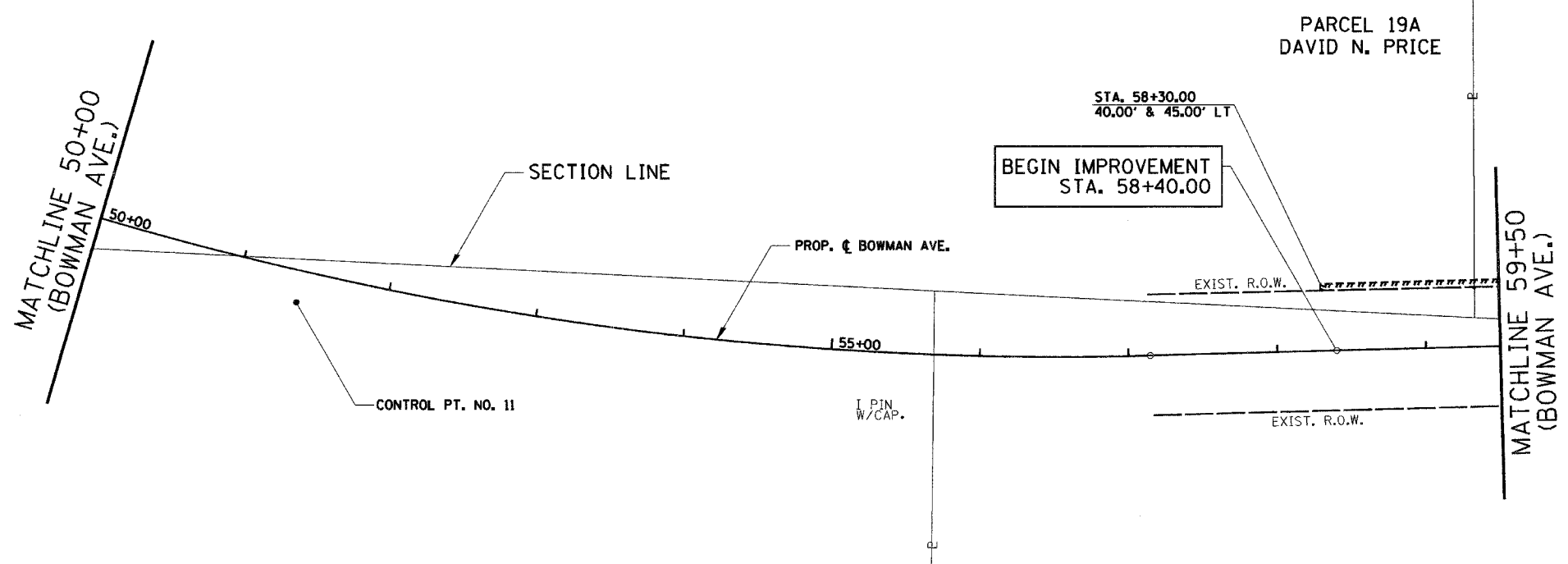

NOTES:
 SEE ATB SHEET 5 OF 6 FOR ALIGNMENT TIES, CONTROL POINTS & BENCHMARKS.
 SEE ATB SHEET 6 OF 6 FOR CURVE DATA.

ATB SHEET 4 OF 6

REVISIONS	
NAME	DATE

CITY OF DANVILLE, ILLINOIS
 WINTER AVENUE RECONSTRUCTION
 ALIGNMENT, TIES, R.O.W.,
 EASEMENTS & BENCHMARKS
 BOWMAN AVENUE
 STA. 41+80.18 TO STA. 59+50
 SCALE: 1" = 50' DATE: 12/21/06
 DRAWN BY: NIL CHECKED BY: SMK

PLAN SURVEYED BY DATE
 PLOTTED BY DATE
 CHECKED BY DATE
 REVISIONS BY DATE
 NO. OF WAYS CHECKED
 CAD FILE NAME
 NO.

CURVE	NO. 1	NO. 2	NO. 3	NO. 4	NO. 5	NO. 6	NO. 7	NO. 8	NO. 9	NO. 10
P.I. STA.	121+37.67	49+77.62	205+38.98	205+65.59	207+20.40	207+81.34	218+86.52	219+43.86	220+25.30	220+82.41
P.I. COORD.	N 1,273,163.62 E 1,185,903.93	N 1,272,064.47 E 1,188,663.31	N 1,273,044.41 E 1,184,309.73	N 1,273,047.31 E 1,184,336.19	N 1,273,055.95 E 1,184,490.77	N 1,273,051.93 E 1,184,551.64	N 1,273,113.65 E 1,185,655.18	N 1,273,111.85 E 1,185,712.52	N 1,273,116.40 E 1,185,793.85	N 1,273,124.55 E 1,185,850.41
Δ	0° 24' 03" (LT)	38° 29' 33" (LT)	3° 03' 01" (LT)	3° 03' 01" (RT)	6° 58' 57" (RT)	6° 58' 57" (LT)	5° 00' 00" (RT)	5° 00' 00" (LT)	5° 00' 00" (LT)	4° 47' 59" (RT)
D	0° 24' 02"	2° 30' 31"	11° 27' 33"	11° 27' 33"	11° 27' 33"	11° 27' 33"	11° 27' 33"	11° 27' 33"	11° 27' 33"	11° 27' 33"
T	50.01	797.44	13.31	13.31	30.5	30.5	21.83	21.83	21.83	20.95
L	100.03	1,534.44	26.62	26.62	60.93	60.93	43.63	43.63	43.63	41.88
R	14,300.00	2,284.00	500	500	500	500	500	500	500	500
E	0.09	135.21	0.18	0.18	0.93	0.93	0.48	0.48	0.48	0.44
P.C. STA.	120+87.66	41+80.18	205+25.66	205+52.28	206+89.90	207+50.83	218+64.69	219+22.03	220+03.47	220+61.46
P.C. COORD.	N 1,273,160.83 E 1,185,853.99	N 1,271,400.07 E 1,188,222.30	N 1,273,043.66 E 1,184,296.44	N 1,273,045.86 E 1,184,322.96	N 1,273,054.25 E 1,184,460.31	N 1,273,053.94 E 1,184,521.21	N 1,273,112.43 E 1,185,633.38	N 1,273,112.53 E 1,185,690.70	N 1,273,115.18 E 1,185,772.06	N 1,273,121.56 E 1,185,829.67
P.T. STA.	121+87.69	57+14.62	205+52.28	205+78.90	207+50.83	208+11.77	219+08.32	219+65.66	220+47.10	221+03.34
P.T. COORD.	N 1,273,166.76 E 1,185,953.85	N 1,272,858.97 E 1,188,594.95	N 1,273,045.86 E 1,184,322.96	N 1,273,048.05 E 1,184,349.48	N 1,273,053.94 E 1,184,521.21	N 1,273,053.63 E 1,184,582.10	N 1,273,112.96 E 1,185,676.99	N 1,273,113.07 E 1,185,734.31	N 1,273,119.51 E 1,185,815.46	N 1,273,125.79 E 1,185,871.33

CURVE	NO. 11	NO. 12	NO. 13	NO. 14	NO. 15	NO. 16	NO. 17	NO. 18	NO. 19	NO. 20
P.I. STA.	221+93.87	222+50.99	223+31.96	223+89.30	225+66.17	226+23.51	227+04.48	227+61.82	228+42.79	229+00.14
P.I. COORD.	N 1,273,131.16 E 1,185,961.70	N 1,273,129.77 E 1,186,018.82	N 1,273,134.86 E 1,186,099.66	N 1,273,143.44 E 1,186,156.39	N 1,273,154.55 E 1,186,332.93	N 1,273,153.15 E 1,186,390.28	N 1,273,158.24 E 1,186,471.12	N 1,273,166.82 E 1,186,527.85	N 1,273,171.91 E 1,186,608.69	N 1,273,170.51 E 1,186,666.04
Δ	4° 47' 59" (RT)	5° 00' 00" (LT)	5° 00' 00" (LT)	5° 00' 00" (RT)	5° 00' 00" (RT)	5° 00' 00" (LT)	5° 00' 00" (LT)	5° 00' 00" (RT)	5° 00' 00" (RT)	5° 00' 00" (LT)
D	11° 27' 33"	11° 27' 33"	11° 27' 33"	11° 27' 33"	11° 27' 33"	11° 27' 33"	11° 27' 33"	11° 27' 33"	11° 27' 33"	11° 27' 33"
T	20.95	21.83	21.83	21.83	21.83	21.83	21.83	21.83	21.83	21.83
L	41.88	43.63	43.63	43.63	43.63	43.63	43.63	43.63	43.63	43.63
R	500	500	500	500	500	500	500	500	500	500
E	0.44	0.48	0.48	0.48	0.48	0.48	0.48	0.48	0.48	0.48
P.C. STA.	221+72.92	222+29.16	223+10.13	223+67.47	225+44.34	226+01.68	226+82.65	227+39.99	228+20.96	228+78.30
P.C. COORD.	N 1,273,129.92 E 1,185,940.78	N 1,273,130.30 E 1,185,997.00	N 1,273,133.49 E 1,186,077.88	N 1,273,140.17 E 1,186,134.80	N 1,273,153.18 E 1,186,311.14	N 1,273,153.69 E 1,186,368.46	N 1,273,156.87 E 1,186,449.34	N 1,273,163.56 E 1,186,506.26	N 1,273,170.54 E 1,186,586.90	N 1,273,171.05 E 1,186,644.21
P.T. STA.	222+14.80	222+72.79	223+53.76	224+11.10	225+87.97	226+45.31	227+26.28	227+83.63	228+64.60	229+21.94
P.T. COORD.	N 1,273,130.65 E 1,185,982.65	N 1,273,131.14 E 1,186,040.61	N 1,273,138.12 E 1,186,121.25	N 1,273,144.81 E 1,186,178.17	N 1,273,154.02 E 1,186,354.76	N 1,273,154.53 E 1,186,412.07	N 1,273,161.51 E 1,186,492.71	N 1,273,168.20 E 1,186,549.63	N 1,273,171.38 E 1,186,630.51	N 1,273,171.88 E 1,186,687.83

CURVE	NO. 21	NO. 22	NO. 23	NO. 24	NO. 25	NO. 26	NO. 27	NO. 28	NO. 29	NO. 30
P.I. STA.	229+81.11	230+38.45	231+19.42	231+76.76	232+57.73	233+15.07	233+96.05	234+53.39	235+34.36	235+91.70
P.I. COORD.	N 1,273,175.60 E 1,186,746.88	N 1,273,184.18 E 1,186,803.60	N 1,273,189.27 E 1,186,884.44	N 1,273,187.87 E 1,186,941.79	N 1,273,192.96 E 1,187,022.63	N 1,273,201.54 E 1,187,079.36	N 1,273,206.63 E 1,187,160.20	N 1,273,205.23 E 1,187,217.55	N 1,273,210.32 E 1,187,298.39	N 1,273,218.90 E 1,187,355.11
Δ	5° 00' 00" (LT)	5° 00' 00" (RT)	5° 00' 00" (RT)	5° 00' 00" (LT)	5° 00' 00" (LT)	5° 00' 00" (RT)	5° 00' 00" (RT)	5° 00' 00" (LT)	5° 00' 00" (LT)	5° 00' 00" (RT)
D	11° 27' 33"	11° 27' 33"	11° 27' 33"	11° 27' 33"	11° 27' 33"	11° 27' 33"	11° 27' 33"	11° 27' 33"	11° 27' 33"	11° 27' 33"
T	21.83	21.83	21.83	21.83	21.83	21.83	21.83	21.83	21.83	21.83
L	43.63	43.63	43.63	43.63	43.63	43.63	43.63	43.63	43.63	43.63
R	500	500	500	500	500	500	500	500	500	500
E	0.48	0.48	0.48	0.48	0.48	0.48	0.48	0.48	0.48	0.48
P.C. STA.	229+59.28	230+16.62	230+97.59	231+54.93	232+35.90	232+93.24	233+74.22	234+31.56	235+12.53	235+69.87
P.C. COORD.	N 1,273,174.23 E 1,186,725.09	N 1,273,180.92 E 1,186,782.02	N 1,273,187.90 E 1,186,862.65	N 1,273,188.40 E 1,186,919.97	N 1,273,191.59 E 1,187,000.85	N 1,273,198.28 E 1,187,057.77	N 1,273,205.26 E 1,187,138.41	N 1,273,205.76 E 1,187,195.72	N 1,273,208.95 E 1,187,276.60	N 1,273,215.64 E 1,187,333.53
P.T. STA.	230+02.91	230+60.25	231+41.22	231+98.56	232+79.54	233+36.88	234+17.85	234+75.19	235+56.16	236+13.50
P.T. COORD.	N 1,273,178.87 E 1,186,768.46	N 1,273,185.55 E 1,186,825.39	N 1,273,188.74 E 1,186,906.26	N 1,273,189.24 E 1,186,963.58	N 1,273,196.23 E 1,187,044.22	N 1,273,202.91 E 1,187,101.14	N 1,273,206.10 E 1,187,182.02	N 1,273,206.60 E 1,187,239.33	N 1,273,213.58 E 1,187,319.97	N 1,273,220.27 E 1,187,376.90

CURVE	NO. 35	NO. 36
P.I. STA.	244+44.80	245+90.94
P.I. COORD.	N 1,273,272.47 E 1,188,206.10	N 1,273,269.65 E 1,188,352.24
Δ	4° 42' 33" (RT)	4° 42' 33" (LT)
D	11° 27' 33"	11° 27' 33"
T	20.56	20.56
L	41.1	41.1
R	500	500
E	0.42	0.42
P.C. STA.	244+24.24	245+70.38
P.C. COORD.	N 1,273,271.18 E 1,188,185.58	N 1,273,270.04 E 1,188,331.68
P.T. STA.	244+65.34	246+11.48
P.T. COORD.	N 1,273,272.07 E 1,188,226.66	N 1,273,270.94 E 1,188,372.76

CURVE NO. 1 : PROPOSED WINTER AVENUE

CURVE NO. 2 : PROPOSED BOWMAN AVENUE

CURVES NO. 3 - NO. 36 : PROPOSED BICYCLE PATH

REVISIONS		NAME	DATE
NO.	DESCRIPTION		

CITY OF DANVILLE, ILLINOIS
 WINTER AVENUE RECONSTRUCTION
 ALIGNMENT, TIES, R.O.W.,
 EASEMENTS & BENCHMARKS
 CURVE DATA

SCALE: NTS
 DRAWN BY: NIL

DATE: 12/21/06
 CHECKED BY: MBF

F.A.D. RTE.	SECTION	COUNTY	TOTAL SHEETS	SHEET NO.
6998	99-00209-01-PV	VERMILION	296	32
STA. 97+00		TO STA. 103+00		
FED. ROAD DIST. NO. ILLINOIS		FED. AID PROJECT-		
CONTRACT NO.: 91358				

REMOVAL LEGEND

- PAVEMENT REMOVAL
- DRIVEWAY PAVEMENT REMOVAL
- SIDEWALK REMOVAL
- BUILDING REMOVAL
- PAVEMENT REPLACEMENT
- TREE REMOVAL (AC)
- CURB & GUTTER REMOVAL
- GUARDRAIL REMOVAL
- TREE REMOVAL
- TREE TRUNK PROTECTION

SW 1/4 SEC. 28 T20N-R11W 2nd P.M.

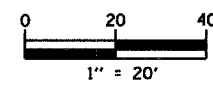

PLAN	DATE
SURVEYED	BY
PLOTTED	BY
CHECKED	BY
RT. OF WAY CHECKED	BY
CADD FILE NAME	
NO.	

TREE TRUNK PROTECTION SCHEDULE

STATION	O/S	LT/RT	TREE TRUNK PROTECTION (EACH) 20101100
100+49.03	23.88'	RT	1
100+55.92	23.96'	RT	1
SHEET TOTALS			2

PAVEMENT REMOVAL SCHEDULE

FROM STATION	TO STATION	PAVEMENT REM (SY) 44000100
100+10.00	102+34.35	610.9
102+43.77	103+00.00	197.2
SHEET TOTAL		808.1

SIDEWALK REMOVAL SCHEDULE

FROM STATION	TO STATION	LT/RT	SIDEWALK REM (SF) 44000600
100+28.91	100+64.18	RT	136.1
100+74.23	101+29.00	RT	212.4
SHEET TOTAL			348.5

TREE REMOVAL SCHEDULE (ACRES)

FROM STATION	TO STATION	LT/RT	TREE REMOV (ACRES) 20100500
102+33	102+78	RT	0.015
SHEET TOTAL			0.015

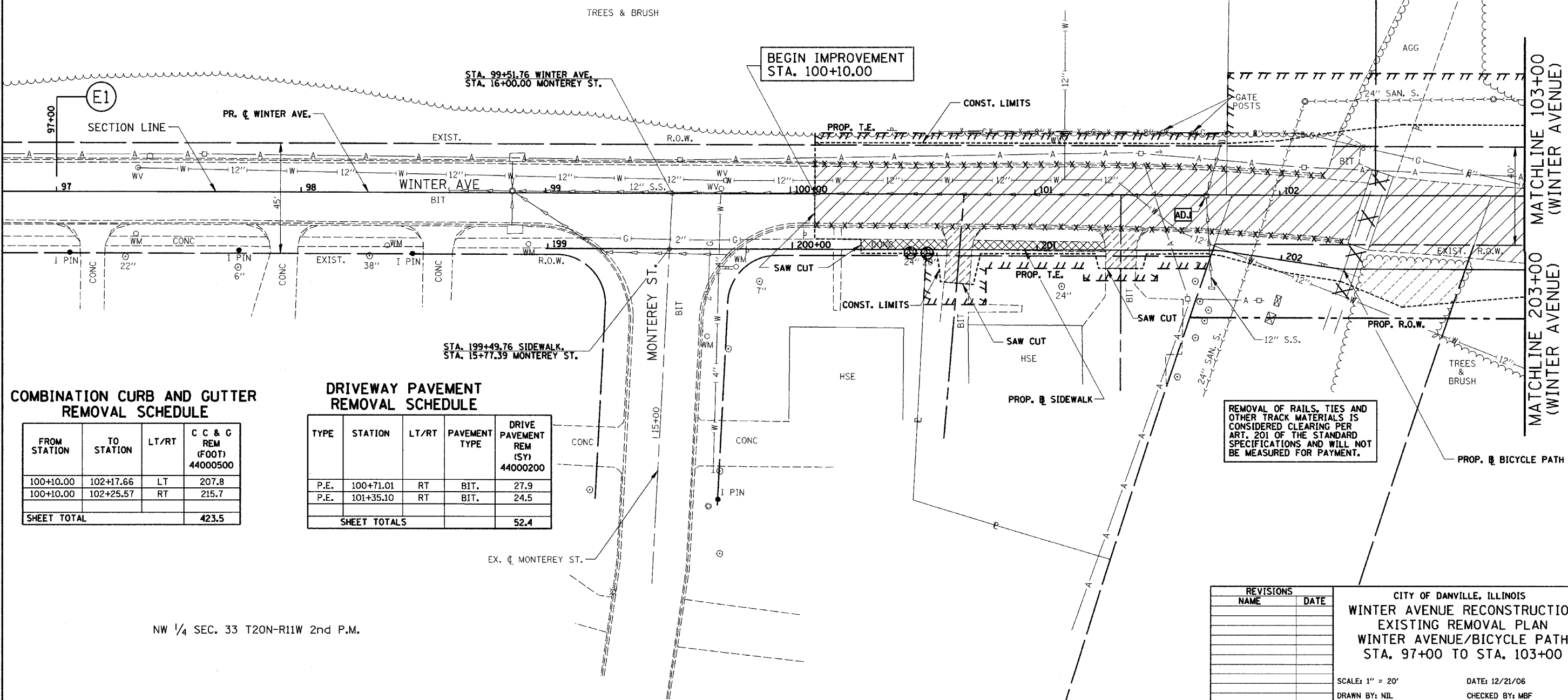

COMBINATION CURB AND GUTTER REMOVAL SCHEDULE

FROM STATION	TO STATION	LT/RT	C C & G REM (FOOT) 44000500
100+10.00	102+17.66	LT	207.8
100+10.00	102+25.57	RT	215.7
SHEET TOTAL			423.5

DRIVEWAY PAVEMENT REMOVAL SCHEDULE

TYPE	STATION	LT/RT	PAVEMENT TYPE	DRIVE PAVEMENT REM (SY) 44000200
P.E.	100+71.01	RT	BIT.	27.9
P.E.	101+35.10	RT	BIT.	24.5
SHEET TOTALS				52.4

NW 1/4 SEC. 33 T20N-R11W 2nd P.M.

REVISIONS	
NAME	DATE

CITY OF DANVILLE, ILLINOIS
WINTER AVENUE RECONSTRUCTION
EXISTING REMOVAL PLAN
WINTER AVENUE/BICYCLE PATH
STA. 97+00 TO STA. 103+00

SCALE: 1" = 20' DATE: 12/21/06
 DRAWN BY: NIL CHECKED BY: MBF

ENTRANCE QUANTITY SCHEDULE

TYPE	STATION	LT/RT	AGG BASE CSE B (CU YD) 35101500	AGG SURF CSE B (TONS) 40200800	BIT MATLS PR CT (GAL) 40800010	INCIDENTAL HMA SURF (TONS) 40800050	PCC DRIVEWAY PAVT 6 (SQ YD) 42300200	TEMP ACCESS- PRIV ENT (EACH) X4021000	TEMP ACCESS- COM ENT (EACH) X4022000
P.E.	100+71.01	RT	3.3	--	5.1	2.5	12.3	1	--
P.E.	101+35.10	RT	1.7	--	2.6	1.3	13.1	1	--
SHEET TOTALS			5.0	--	7.7	3.8	25.4	2	--

SW 1/4 SEC. 28 T20N-R11W 2nd P.M.

**PORTLAND CEMENT CONCRETE
SIDEWALK SCHEDULE**

FROM STATION	TO STATION	PC CONC SIDEWALK 5 INCH (SF) 42400200
200+28.04	202+24.67	934.3
202+24.67	203+00.00	753.3
SHEET TOTAL		1687.6

F.A.U. RTE.	SECTION	COUNTY	TOTAL SHEETS	SHEET NO.
6998	99-00209-01-PV	VERMILION	296	33
STA. 97+00		TO STA. 103+00		
FED. ROAD DIST. NO. ILLINOIS		FED. AID PROJECT-		
CONTRACT NO.: 91358				

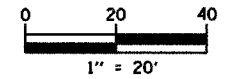

**COMBINATION CONCRETE
CURB & GUTTER, TYPE B-6.24**

FROM STATION	TO STATION	LT/RT	COMB CC&G TB6.24 (FT) 60605000	PROT COAT (SY) 42001300
100+10.00	103+00.00	LT	290.1	96.7
100+10.00	103+00.00	RT	290.1	96.7
SHEET TOTAL			580.2	193.4

PLAN	DATE	BY
SURVEYED		
DESIGNED		
CHECKED		
IN CHARGE		
DATE		
BY		
DATE		
BY		
DATE		

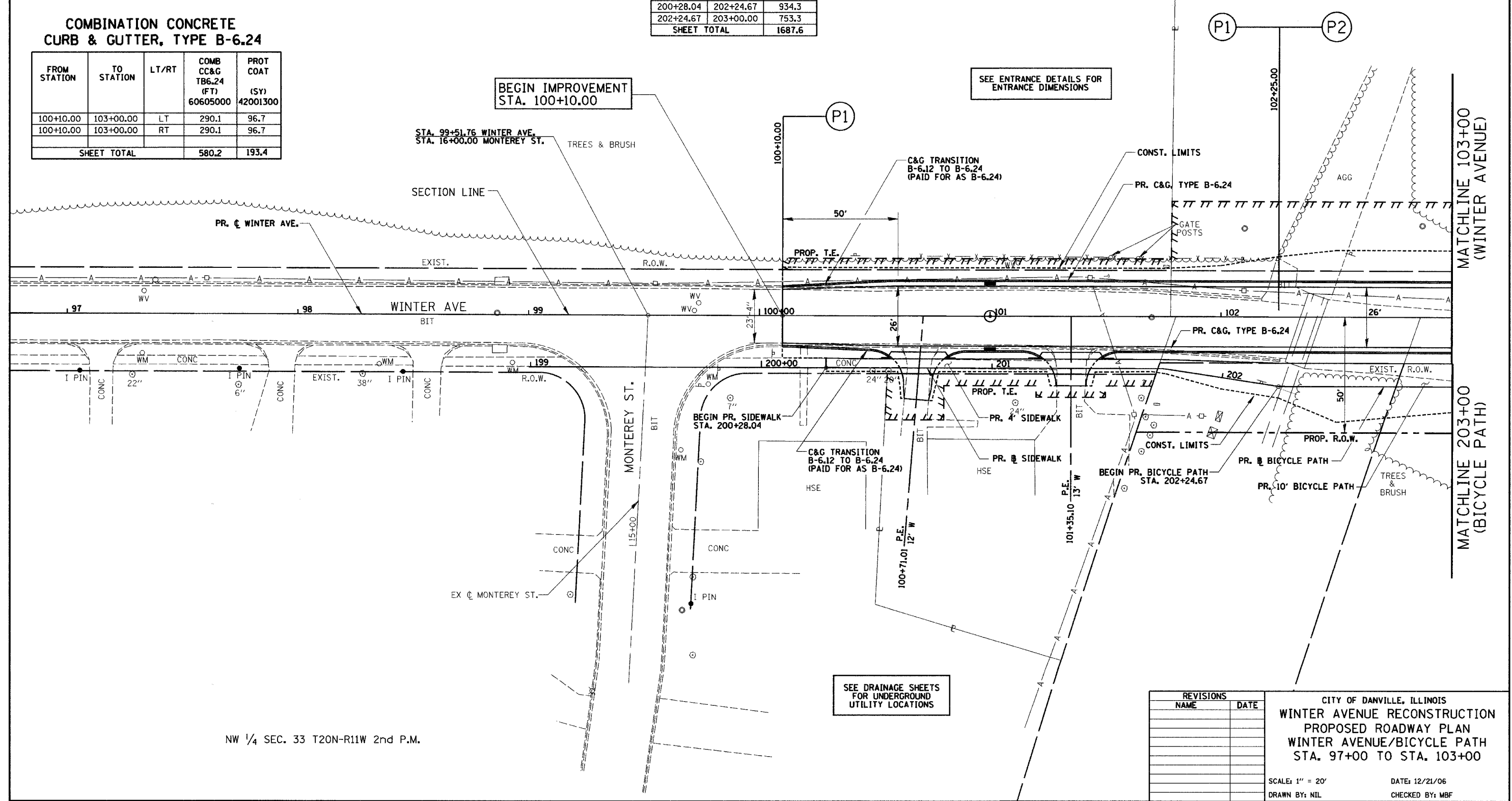

NW 1/4 SEC. 33 T20N-R11W 2nd P.M.

SEE DRAINAGE SHEETS
FOR UNDERGROUND
UTILITY LOCATIONS

SEE ENTRANCE DETAILS FOR
ENTRANCE DIMENSIONS

REVISIONS	
NAME	DATE

CITY OF DANVILLE, ILLINOIS
**WINTER AVENUE RECONSTRUCTION
 PROPOSED ROADWAY PLAN
 WINTER AVENUE/BICYCLE PATH
 STA. 97+00 TO STA. 103+00**

SCALE: 1" = 20' DATE: 12/21/06
 DRAWN BY: NIL CHECKED BY: MBF

F.A.U. RTE.	SECTION	COUNTY	TOTAL SHEETS	SHEET NO.
6998	99-00209-01-PV	VERMILION	296	35
STA. 103+00		TO STA. 109+00		
FED. ROAD DIST. NO. ILLINOIS		FED. AID PROJECT-		
CONTRACT NO.: 91358				

GUARDRAIL SCHEDULE

FROM STATION	TO STATION	LT/RT	REM RE-E T B TERM T6 (EACH) 63302700	REM RE-E SPBGR TY A (FT) 63301210	GUARDRAIL MARKERS (EACH) 78200405
106+85.70	107+18.85	LT	1		
107+18.85	109+00.00	LT		181.15	3
SHEET TOTALS			1	181.15	3

PORTLAND CEMENT CONCRETE SIDEWALK SCHEDULE

FROM STATION	TO STATION	PC CONC SIDEWALK 5" (SF) 42400200	PC CONC SIDEWALK 5" SP (SF) 42400430
203+00.00	205+23.67	2236.7	--
205+23.67	205+61.98	--	633.9
207+07.94	208+11.77	--	1387.2
208+11.77	209+00.00	882.3	--
SHEET TOTALS		3119.0	2021.1

STONE RIPRAP SCHEDULE

FROM STATION	TO STATION	LT/RT	STONE RIPRAP CL A3 (SY) 28100105	STONE RIPRAP CL A2 SP (SY) =5000791	FILTER FABRIC (SY) 28200200
105+42.50	105+51.00	RT	7.2	--	7.2
106+88.20	108+52.08	LT	--	216.7	216.7
108+52.08	109+00.00	LT	--	10.2	10.2
SHEET TOTALS			7.2	226.9	234.1

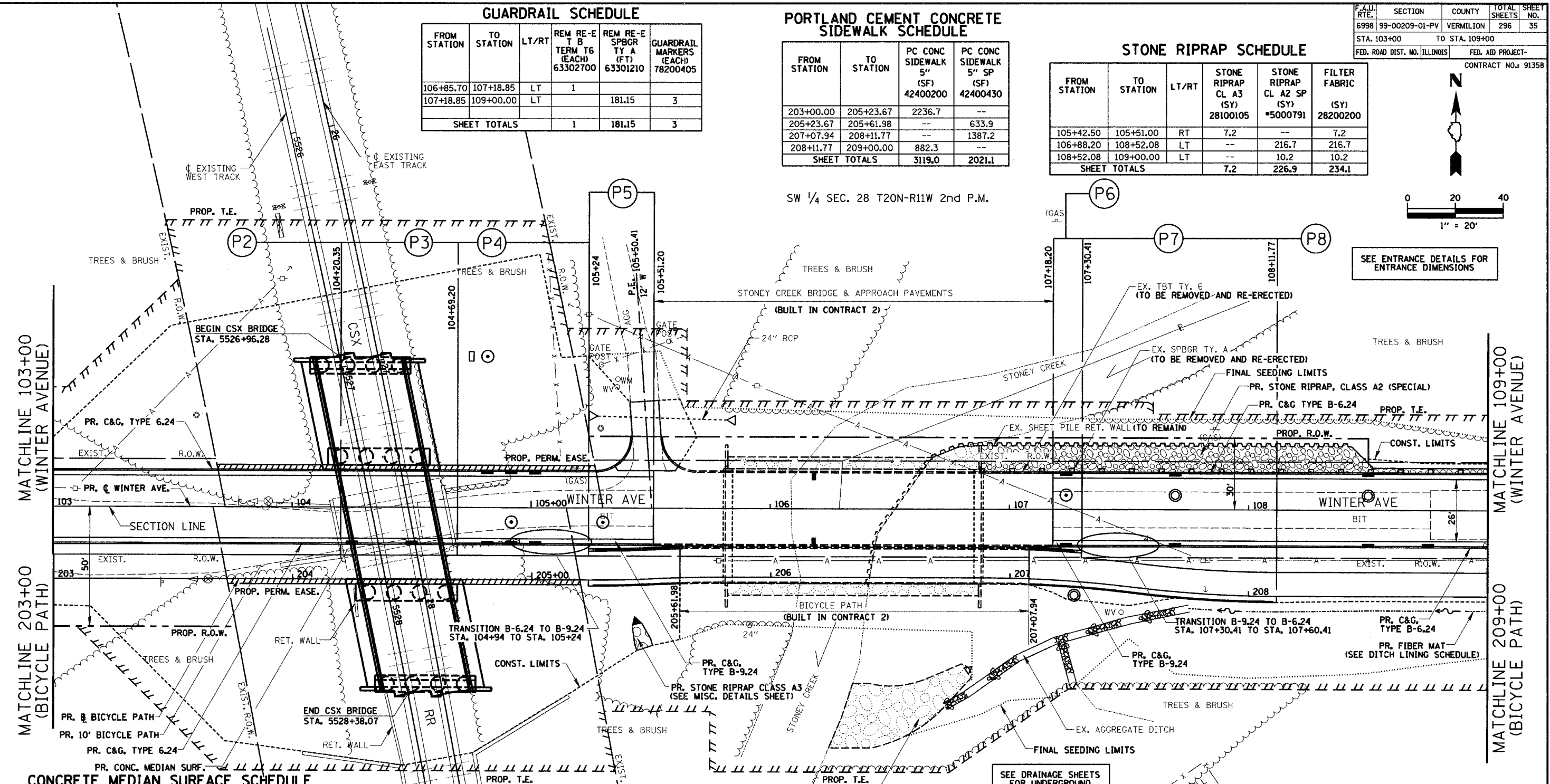

PLAN	DATE
SURVEYED	BY
PLOTTED	BY
CHECKED	BY
REVISIONS	BY
NO.	DATE

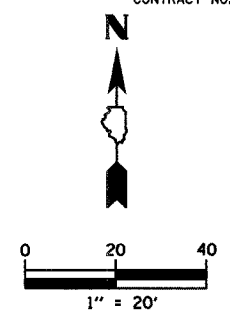

SEE ENTRANCE DETAILS FOR ENTRANCE DIMENSIONS

CONCRETE MEDIAN SURFACE SCHEDULE

FROM STATION	TO STATION	LT/RT	CONC MEDIAN SURF 4 SP (SF) 60618310	PROT COAT (SY) 42001300	LOCATION
104+20.35	104+69.20	RT	215.9	24.0	BTWN. CURB & BIKE PATH
SHEET TOTAL			215.9	24.0	

ENTRANCE QUANTITY SCHEDULE

TYPE	STATION	LT/RT	AGG BASE CSE B (CU YD) 35101500	AGG SURF CSE B (TONS) 40200800	BIT MATLS PR CT (GAL) 40800010	INCIDENTAL HMA SURF (TONS) 40800050	PCC DRIVEWAY PAVT 6 (SQ YD) 42300200	TEMP ACCESS-PRIV ENT (EACH) X4021000	TEMP ACCESS-COM ENT (EACH) X4022000
P.E.	105+50.41	LT	--	5.9	--	--	29.6	1	--
SHEET TOTALS			--	5.9	--	--	29.6	1	--

COMBINATION CONCRETE CURB & GUTTER, TYPE B-6.24

FROM STATION	TO STATION	LT/RT	COMB CC&G TB6.24 (FT) 60605000	PROT COAT (SY) 42001300
103+00.00	105+51.20	LT	251.2	83.7
103+00.00	104+94.00	RT	194.0	64.7
107+18.20	109+00.00	LT	181.8	60.6
107+60.41	109+00.00	RT	139.6	46.5
SHEET TOTAL			766.6	255.5

COMBINATION CONCRETE CURB & GUTTER, TYPE B-9.24

FROM STATION	TO STATION	LT/RT	COMB CC&G TB9.24 (FT) 60607400	PROT COAT (SY) 42001300
104+94.00	105+51.20	RT	57.2	20.1
107+18.20	107+60.41	RT	42.2	14.9
SHEET TOTAL			99.4	35.0

REVISIONS	
NAME	DATE

CITY OF DANVILLE, ILLINOIS
 WINTER AVENUE RECONSTRUCTION
 PROPOSED ROADWAY PLAN
 WINTER AVENUE/BICYCLE PATH
 STA. 103+00 TO STA. 109+00

SCALE: 1" = 20'
 DRAWN BY: NIL
 DATE: 12/21/06
 CHECKED BY: MBF

TREE TRUNK PROTECTION SCHEDULE

STATION	O/S	LT/RT	TREE TRUNK PROTECTION (EACH) 20101100
114+19.98	47.35'	RT	1
114+54.32	40.14'	RT	1
SHEET TOTAL			2

SW 1/4 SEC. 28 T20N-R11W 2nd P.M.

PAVEMENT REMOVAL SCHEDULE

FROM STATION	TO STATION	PAVEMENT REM (SY) 44000100
109+00.00	114+50.00	1456.9
SHEET TOTAL		1456.9

F.A.I.D. RTE.	SECTION	COUNTY	TOTAL SHEETS	SHEET NO.
6998	99-00209-01-PV	VERMILION	296	36
STA. 109+00		TO STA. 115+00		
FED. ROAD DIST. NO. ILLINOIS		FED. AID PROJECT-		
CONTRACT NO.: 91358				

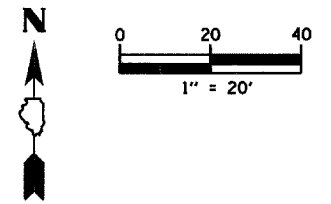

PLAN	DATE	BY
SURVEYED		
PLOTTED		
CHECKED		
DATE		
NOTE BOOK		
NO.		
ADD FILE NAME		

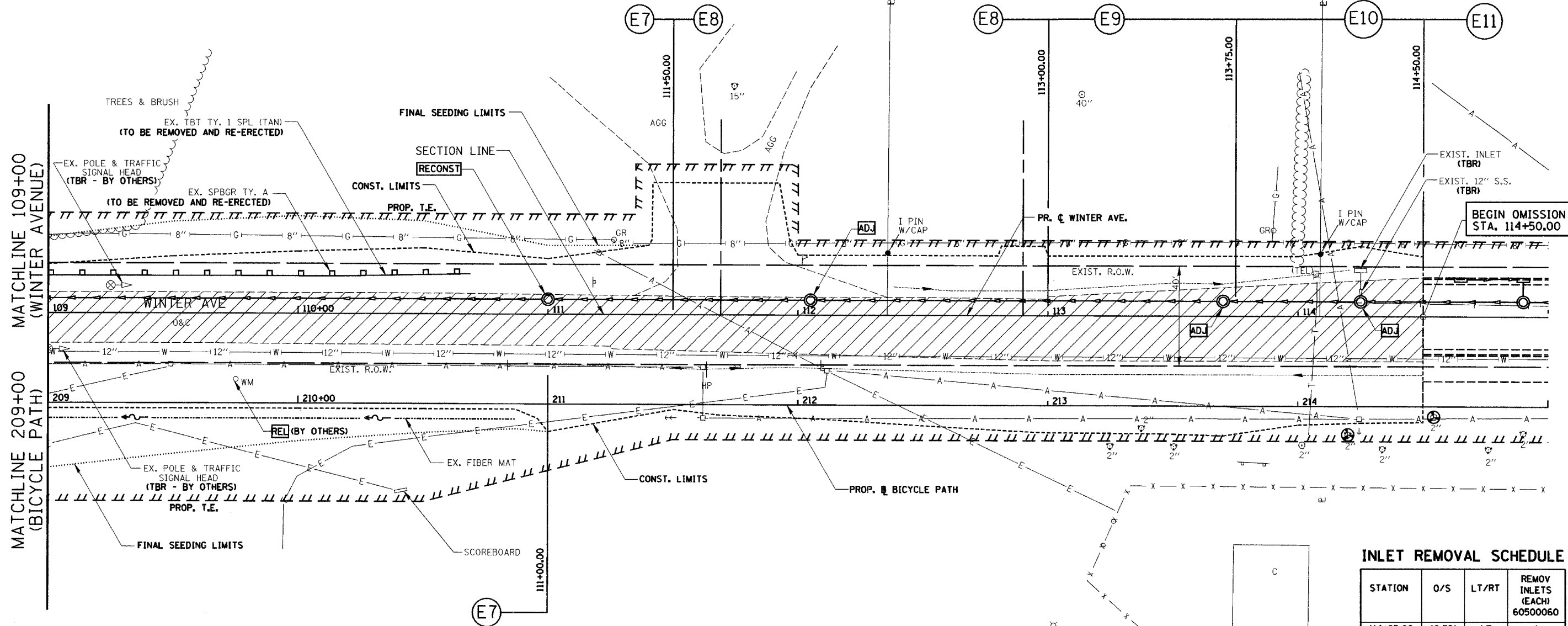

STORM SEWER REMOVAL 12"

FROM STATION	O/S	LT/RT	TO STATION	O/S	LT/RT	STORM SEWER REM (FOOT) 55100500
114+25.00	17.52'	LT	114+25.00	8.50'	LT	9
SHEET TOTAL						9

REMOVAL LEGEND

- PAVEMENT REMOVAL
- DRIVEWAY PAVEMENT REMOVAL
- SIDEWALK REMOVAL
- BUILDING REMOVAL
- CURB & GUTTER REMOVAL
- GUARDRAIL REMOVAL
- BITUMINOUS TAPER (FOR BUTT JOINTS)
- TREE REMOVAL (AC)
- TREE REMOVAL
- TREE TRUNK PROTECTION

INLET REMOVAL SCHEDULE

STATION	O/S	LT/RT	REMOV INLETS (EACH) 60500060
114+25.00	18.52'	LT	1
SHEET TOTAL			1

REVISIONS	
NAME	DATE

CITY OF DANVILLE, ILLINOIS
WINTER AVENUE RECONSTRUCTION
 EXISTING REMOVAL PLAN
 WINTER AVENUE/BICYCLE PATH
 STA. 109+00 TO STA. 115+00

SCALE: 1" = 20' DATE: 12/21/06
 DRAWN BY: NIL CHECKED BY: MBF

NW 1/4 SEC. 33 T20N-R11W 2nd P.M.

F.A.J. RTE.	SECTION	COUNTY	TOTAL SHEETS	SHEET NO.
6998	99-00209-01-PV	VERMILION	296	37
STA. 109+00		TO STA. 115+00		
FED. ROAD DIST. NO. ILLINOIS		FED. AID PROJECT-		
CONTRACT NO.: 91358				

GUARDRAIL SCHEDULE

FROM STATION	TO STATION	LT/RT	REM RE-ESTY A (FT) 63301210	REM RE-ESTY B TERM T1 (EACH) 63301990	GUARDRAIL MARKERS (EACH) 78200405	TERMINAL MARKER -DA (EACH) 78201000
109+00.00	110+18.85	LT	118.85		2	
110+18.85	110+68.85	LT		1		1
SHEET TOTALS			118.85	1	2	1

STONE RIPRAP SCHEDULE

FROM STATION	TO STATION	LT/RT	STONE RIPRAP CL A2 SP (SY) *5000791	FILTER FABRIC (SY) 28200200
109+00.00	110+75.72	LT	40.0	40.0
SHEET TOTALS			40.0	40.0

SW 1/4 SEC. 28 T20N-R11W 2nd P.M.

SEE ENTRANCE DETAILS FOR ENTRANCE DIMENSIONS

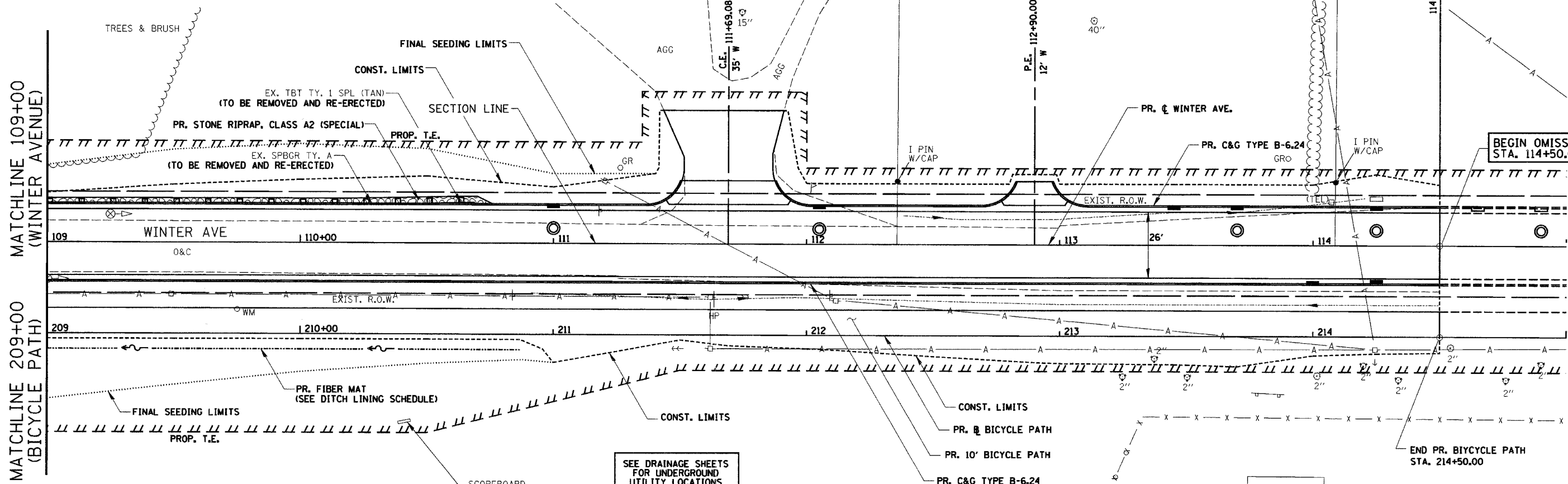
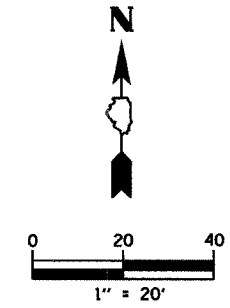

NW 1/4 SEC. 33 T20N-R11W 2nd P.M.

ENTRANCE QUANTITY SCHEDULE

TYPE	STATION	LT/RT	AGG BASE CSE B (CU YD) 35101500	AGG SURF CSE B (TONS) 40200800	BIT MATLS PR CT (GAL) 40800010	INCIDENTAL HMA SURF (TONS) 40800050	PCC DRIVEWAY PAVT 6 (SQ YD) 42300200	TEMP ACCESS-PRIV ENT (EACH) X4021000	TEMP ACCESS-COM ENT (EACH) X4022000
C.E.	111+69.08	LT	--	36.0	--	--	45.9	--	1
P.E.	112+90.00	LT	--	--	--	--	21.8	--	--
SHEET TOTALS			--	36.0	--	--	67.7	--	1

COMBINATION CONCRETE CURB & GUTTER, TYPE B-6.24

FROM STATION	TO STATION	LT/RT	COMB CC&G TB6.24 (FT) 60605000	PROT COAT (SY) 42001300
109+00.00	114+50.00	LT	550.0	183.3
109+00.00	114+50.00	RT	550.0	183.3
SHEET TOTAL			1100.0	366.6

PORTLAND CEMENT CONCRETE SIDEWALK SCHEDULE

FROM STATION	TO STATION	PC CONC SIDEWALK 5 INCH (SF) 42400200
209+00.00	214+50.00	5500.0
SHEET TOTAL		5500.0

REVISIONS	
NAME	DATE

CITY OF DANVILLE, ILLINOIS
 WINTER AVENUE RECONSTRUCTION
 PROPOSED ROADWAY PLAN
 WINTER AVENUE/BICYCLE PATH
 STA. 109+00 TO STA. 115+00

SCALE: 1" = 20'
 DRAWN BY: NIL
 DATE: 12/21/06
 CHECKED BY: MBF

DATE: _____
 BY: _____
 SURVEYED: _____
 PLOTTED: _____
 CHECKED: _____
 RT. OF WAY CHECKED: _____
 CAD FILE NAME: _____

CULVERT REMOVAL SCHEDULE

TYPE	FROM STATION	O/S	LT/RT	TO STATION	O/S	LT/RT	SIZE (IN)	PIPE CULVERT REMOV (FOOT) 50105220
RCP	142+00.00	26.43'	RT	142+00.00	42.09'	RT	12	15.7
CMP	142+27.22	23.51'	RT	142+55.22	23.57'	RT	12	28.0
SHEET TOTAL								43.7

SE 1/4 SEC. 28 T20N-R11W 2nd P.M.

PAVEMENT REMOVAL SCHEDULE

FROM STATION	TO STATION	PAVEMENT REM (SY) 44000100
141+50.00	145+00.00	1083.7
SHEET TOTAL		1083.7

TREE REMOVAL SCHEDULE (ACRES)

FROM STATION	TO STATION	LT/RT	TREE REMOV (ACRES) 20100500
142+14	142+31	LT	0.002
144+45	145+00	LT	0.015
SHEET TOTAL			0.017

F.A.U. RTE.	SECTION	COUNTY	TOTAL SHEETS	SHEET NO.
6998	99-00209-01-PV	VERMILION	296	38
STA. 139+00		TO STA. 145+00		
FED. ROAD DIST. NO. ILLINOIS		FED. AID PROJECT- CONTRACT NO.: 91358		

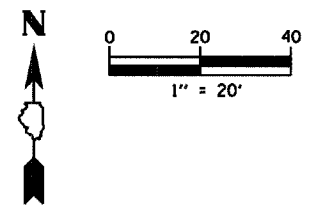

DRIVEWAY PAVEMENT REMOVAL SCHEDULE

TYPE	STATION	LT/RT	PAVEMENT TYPE	DRIVE PAVEMENT REM (SY) 44000200
P.E.	143+50.37	LT	BIT.	31.9
SHEET TOTALS				31.9

PLAN	DATE	BY
SURVEYED		
PLOTTED		
CHECKED		
DATE		
NO.		

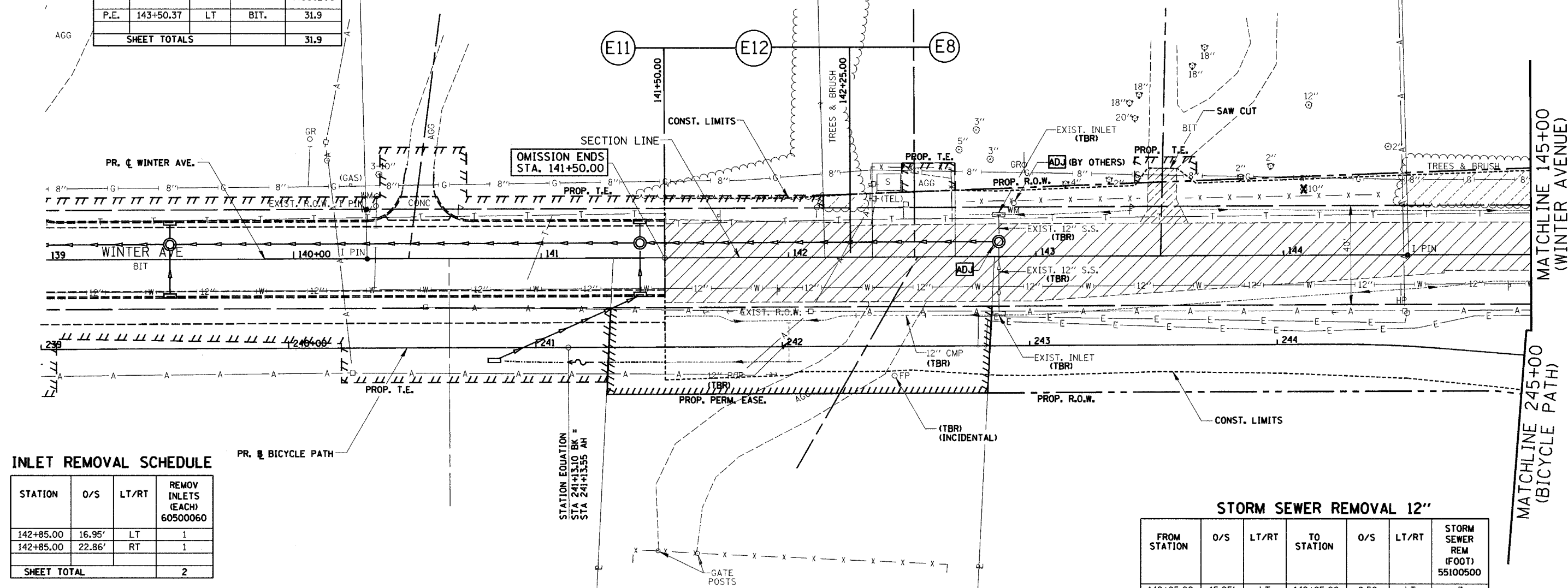

INLET REMOVAL SCHEDULE

STATION	O/S	LT/RT	REMOV INLETS (EACH) 60500060
142+85.00	16.95'	LT	1
142+85.00	22.86'	RT	1
SHEET TOTAL			2

STORM SEWER REMOVAL 12"

FROM STATION	O/S	LT/RT	TO STATION	O/S	LT/RT	STORM SEWER REM (FOOT) 55100500
142+85.00	15.95'	LT	142+85.00	8.50	LT	7
142+85.00	21.86'	RT	142+85.00	3.50	LT	25
SHEET TOTAL						32

REMOVAL LEGEND

- PAVEMENT REMOVAL
- DRIVEWAY PAVEMENT REMOVAL
- SIDEWALK REMOVAL
- BUILDING REMOVAL
- CURB & GUTTER REMOVAL
- GUARDRAIL REMOVAL
- BITUMINOUS TAPER (FOR BUTT JOINTS)
- TREE REMOVAL (AC)
- TREE REMOVAL
- TREE TRUNK PROTECTION

TREE REMOVAL SCHEDULE (6" TO 15")

STATION	O/S	LT/RT	SIZE (IN)	TREE REMOV 6-15 (UNIT) 20100110
144+08.31	26.73'	LT	10	10
TOTALS				10

NE 1/4 SEC. 33 T20N-R11W 2nd P.M.

REVISIONS	
NAME	DATE

CITY OF DANVILLE, ILLINOIS
WINTER AVENUE RECONSTRUCTION
EXISTING REMOVAL PLAN
WINTER AVENUE/BICYCLE PATH
 STA. 139+00 TO STA. 145+00

SCALE: 1" = 20'
 DRAWN BY: NIL
 DATE: 12/21/06
 CHECKED BY: MBF

F.A.I.D. RTE.	SECTION	COUNTY	TOTAL SHEETS	SHEET NO.
6998	99-00209-01-PV	VERMILION	296	39
STA. 139+00		TO STA. 145+00		
FED. ROAD DIST. NO. ILLINOIS		FED. AID PROJECT-		
CONTRACT NO.: 91358				

SE 1/4 SEC. 28 T20N-R11W 2nd P.M.

SEE ENTRANCE DETAILS FOR ENTRANCE DIMENSIONS

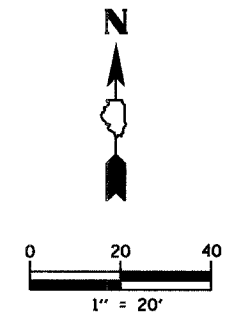

PLAN	SURVEYED	DATE
	BY	
	NOTED	
	REVISIONS	
	NO. OF REVISIONS	
	DATE	
	BY	
	DATE	
	BY	
	DATE	

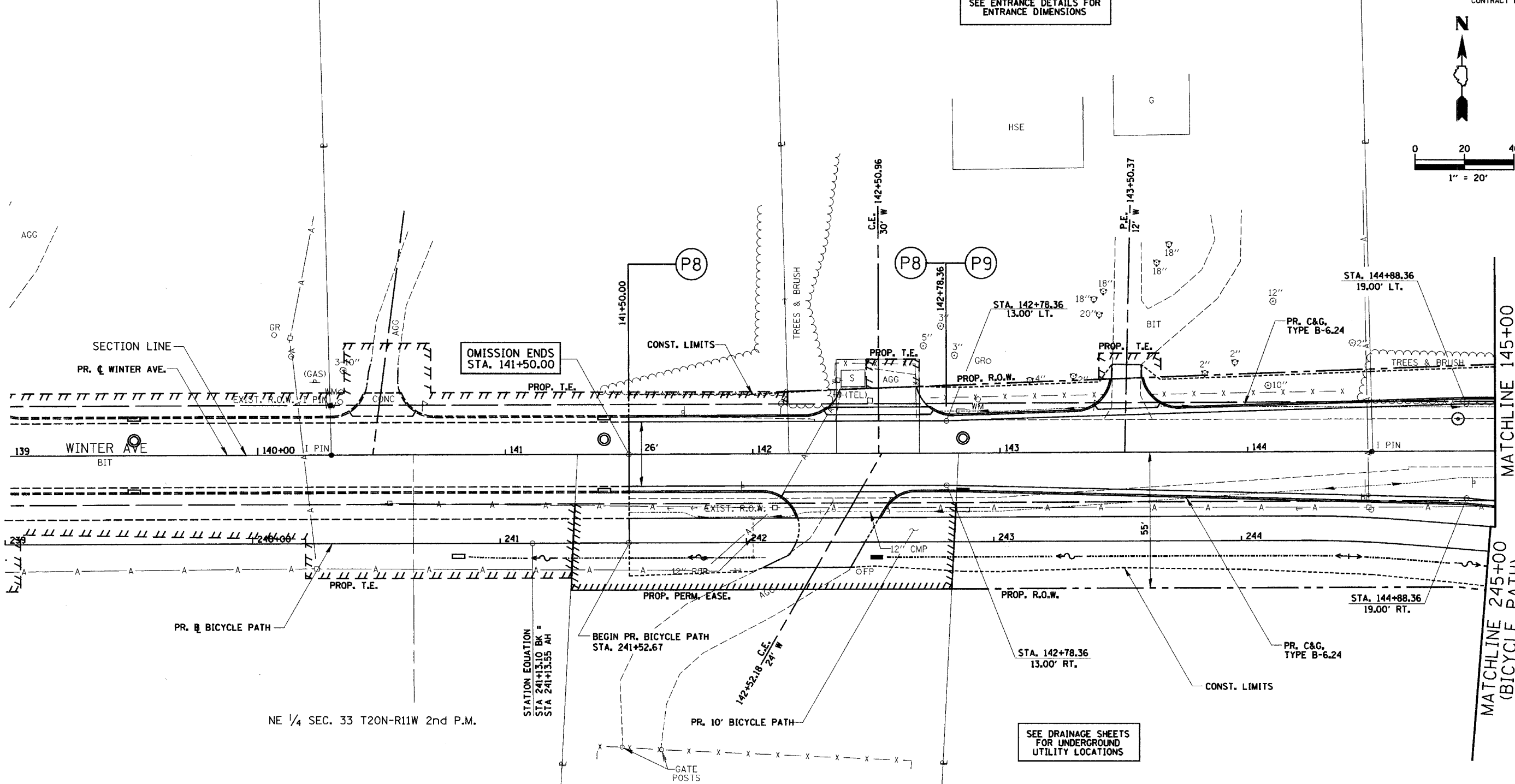

ENTRANCE QUANTITY SCHEDULE

TYPE	STATION	LT/RT	AGG BASE CSE B (CU YD) 35101500	AGG SURF CSE B (TONS) 40200800	BIT MATLS PR CT (GAL) 40800010	INCIDENTAL HMA SURF (TONS) 40800050	PCC DRIVEWAY PAVT 6 (SQ YD) 42300200	TEMP ACCESS-PRIV ENT (EACH) X4021000	TEMP ACCESS-COM ENT (EACH) X4022000
C.E.	142+50.96	LT	--	8.9	--	--	14.5	--	1
C.E.	142+52.18	RT	7.3	--	11.6	5.5	47.0	--	1
P.E.	143+50.37	LT	1.7	--	2.6	1.3	26.2	1	--
SHEET TOTALS			9.0	8.9	14.2	6.8	87.7	1	2

COMBINATION CONCRETE CURB & GUTTER, TYPE B-6.24

FROM STATION	TO STATION	LT/RT	COMB CC&G TB6.24 (FT) 60605000	PROT COAT (SY) 42001300
141+50.00	145+00.00	LT	350.1	116.7
141+50.00	145+00.00	RT	350.1	116.7
SHEET TOTAL			700.2	233.4

PORTLAND CEMENT CONCRETE SIDEWALK SCHEDULE

FROM STATION	TO STATION	PC CONC SIDEWALK 5 INCH (SF) 42400200
241+52.67	245+00.00	3477.4
SHEET TOTAL		3477.4

REVISIONS	
NAME	DATE

CITY OF DANVILLE, ILLINOIS
 WINTER AVENUE RECONSTRUCTION
 PROPOSED ROADWAY PLAN
 WINTER AVENUE/BICYCLE PATH
 STA. 139+00 TO STA. 145+00

SCALE: 1" = 20'
 DRAWN BY: NIL
 DATE: 12/21/06
 CHECKED BY: MBF

REMOVAL LEGEND

	PAVEMENT REMOVAL		CURB & GUTTER REMOVAL
	DRIVEWAY PAVEMENT REMOVAL		GUARDRAIL REMOVAL
	SIDEWALK REMOVAL		BITUMINOUS TAPER (FOR BUTT JOINTS)
	BUILDING REMOVAL		TREE REMOVAL (AC)

⊗ TREE REMOVAL ⊙ TREE TRUNK PROTECTION

DRIVEWAY PAVEMENT REMOVAL SCHEDULE

TYPE	STATION	LT/RT	PAVEMENT TYPE	DRIVEWAY PAVEMENT REM (SY)
WINTER AVENUE				
C.E.	150+91.21	RT	BIT.	57.4
BOWMAN AVENUE				
P.E.	60+35.78	LT	BIT.	27.5
C.E.	60+40.29	RT	CONC.	81.9
SHEET TOTAL				
				166.8

SW 1/4 SEC. 27 T20N-R11W 2nd P.M.

F.A.U. RTE.	SECTION	COUNTY	TOTAL SHEETS	SHEET NO.
6998	99-00209-01-PV	VERMILION	296	40
STA. 145+00		TO STA. 151+00		
FED. ROAD DIST. NO. ILLINOIS		FED. AID PROJECT-		
CONTRACT NO.: 91358				

TREE REMOVAL SCHEDULE (6" TO 15")

STATION	O/S	LT/RT	SIZE (IN)	TREE REMOV 6-15 (UNIT) 20100110
147+33.42	36.88'	RT	6	6
148+60.78	41.12'	RT	7	7
149+25.06	31.30'	LT	12	60
150+59.43	34.00'	RT	6	6
SHEET TOTAL				
				79

TREE REMOVAL SCHEDULE (OVER 15")

STATION	O/S	LT/RT	SIZE (IN)	TREE REMOV OVER 15 (UNIT) 20100210
146+03.82	46.96'	RT	20	20
146+37.16	67.66'	RT	20	20
SHEET TOTAL				
				40

SE 1/4 SEC. 28 T20N-R11W 2nd P.M.

MATCHLINE 145+00 (WINTER AVENUE)

MATCHLINE 245+00 (BICYCLE PATH)

MATCHLINE 63+50 (BOWMAN AVENUE)

MATCHLINE 151+00 (WINTER AVENUE)

COMBINATION CURB AND GUTTER REMOVAL SCHEDULE

FROM STATION	TO STATION	LT/RT	C C & G REM (FOOT) 44000500
147+24.57	147+62.58	RT	45.8
147+32.17	147+64.79	LT	48.1
148+20.88	148+55.00	LT	46.5
148+21.60	148+57.77	RT	47.8
SHEET TOTAL			188.2

NE 1/4 SEC. 33 T20N-R11W 2nd P.M.

PAVEMENT REMOVAL SCHEDULE

FROM STATION	TO STATION	PAVEMENT REM (SY) 44000100
WINTER AVENUE		
145+00.00	147+50.00	663.8
148+50.00	151+00.00	680.3
BOWMAN AVENUE		
60+00.00	63+50.00	1805.8
SHEET TOTAL		3149.9

TREE REMOVAL SCHEDULE (ACRES)

FROM STATION	TO STATION	LT/RT	TREE REMOV (ACRES) 20100500
145+00	146+83	LT	0.047
SHEET TOTAL			0.047

CULVERT REMOVAL SCHEDULE

TYPE	FROM STATION	O/S	LT/RT	TO STATION	O/S	LT/RT	SIZE (IN)	PIPE CULVERT REMOV (FOOT) 50105220
WINTER AVENUE								
CMP	146+69.84	8.99'	RT	146+85.78	16.83'	LT	12	30.4
CMP	148+57.71	24.89'	LT	148+95.96	23.50'	LT	15	38.3
CPP	150+14.09	19.31'	LT	150+15.12	16.71'	RT	12	36.0
CMP	150+68.05	25.93'	RT	151+04.64	15.66'	RT	12	38.0
BOWMAN AVENUE								
CMP	60+21.23	27.76'	LT	60+49.63	27.13'	LT	15	28.4
RCCP	62+49.56	28.90'	RT	62+50.57	29.69'	LT	30x19	58.6
SHEET TOTAL								229.7

TREE TRUNK PROTECTION SCHEDULE

STATION	O/S	LT/RT	TREE TRUNK PROTECTION (EACH) 20101100
WINTER AVE.			
150+34.21	34.34'	RT	1
BOWMAN AVE.			
60+78.24	40.12'	RT	1
SHEET TOTAL			2

REVISIONS	
NAME	DATE

CITY OF DANVILLE, ILLINOIS
WINTER AVENUE RECONSTRUCTION EXISTING REMOVAL PLAN
 WINTER AVENUE/BOWMAN AVENUE
 STA. 145+00 TO STA. 151+00
 STA. 60+00 TO STA. 63+50
 SCALE: 1" = 20'
 DATE: 12/21/06
 DRAWN BY: NIL
 CHECKED BY: MBF

PLAN SURVEYED, PLOTTED, CHECKED, DATE, BY, NOTE BOOK NO., FILE NAME

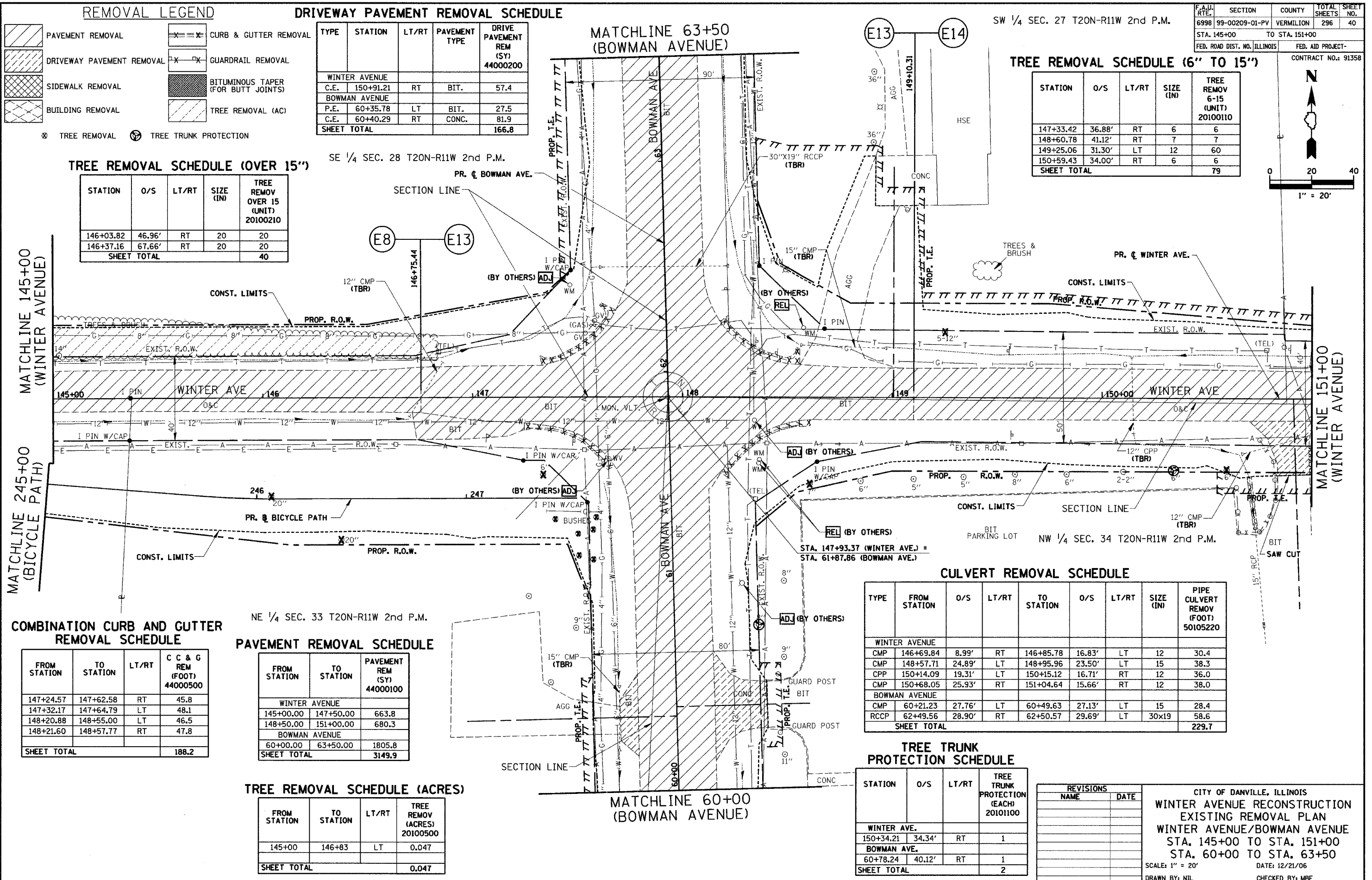
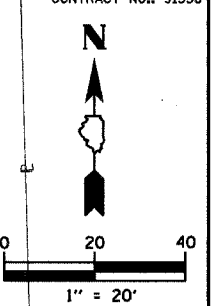

ENTRANCE QUANTITY SCHEDULE

TYPE	STATION	LT/RT	AGG BASE CSE B (CU YD)	AGG SURF CSE B (TONS)	BIT MATLS PR CT (GAL)	INCIDENTAL HMA SURF (TONS)	PCC DRIVEWAY PAVT 6 (SQ YD)	TEMP ACCESS-PRIV ENT (EACH)	TEMP ACCESS-COM ENT (EACH)
WINTER AVE.									
P.E.	149+00.64	LT	--	--	--	--	89.2	1	--
C.E.	150+91.21	RT	--	--	--	--	37.8	--	1
BOWMAN AVE.									
P.E.	60+35.78	LT	--	--	--	--	44.4	1	--
C.E.	60+40.29	RT	1.8	--	2.8	1.4	62.0	--	1
SHEET TOTALS			1.8	--	2.8	1.4	233.4	2	2

F.A.I.D. RTE.	SECTION	COUNTY	TOTAL SHEETS	SHEET NO.
6998	99-00209-01-PV	VERMILION	296	41
STA. 145+00		TO STA. 151+00		
FED. ROAD DIST. NO. ILLINOIS		FED. AID PROJECT-		
CONTRACT NO.: 91358				

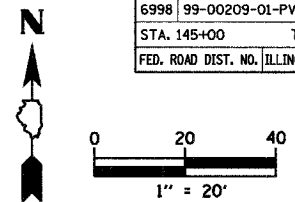

DATE	BY	REVISION

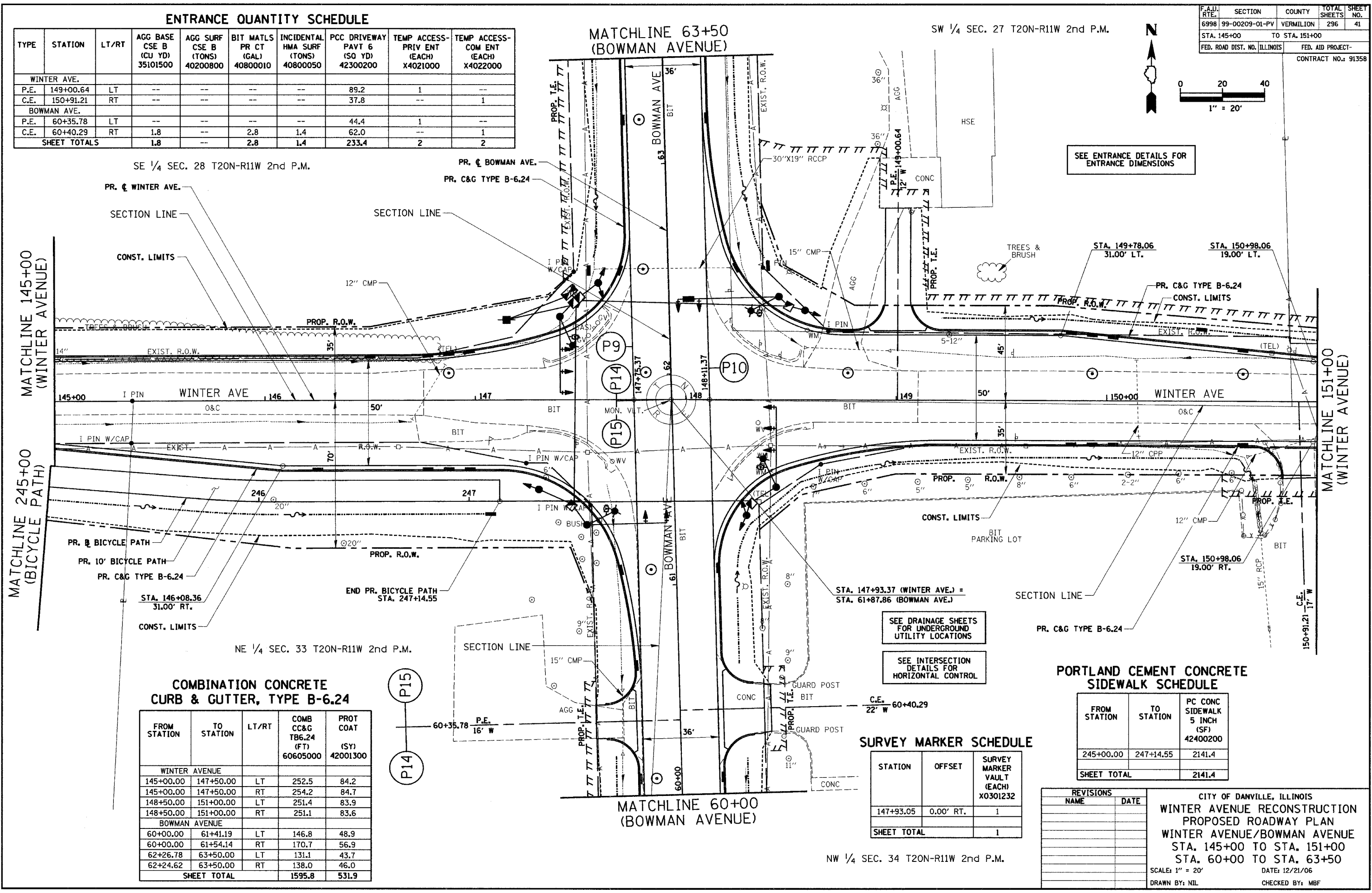

SE 1/4 SEC. 28 T20N-R11W 2nd P.M.

PR. C BOWMAN AVE.
PR. C&G TYPE B-6.24

SECTION LINE

CONST. LIMITS

12" CMP

PROP. R.O.W.

EXIST. R.O.W.

145+00

I PIN

WINTER AVE

O&C

146

50'

147

BIT

148

149

50'

150+00

WINTER AVE

O&C

151+00

CONST. LIMITS

12" CMP

PROP. R.O.W.

EXIST. R.O.W.

150+98.06

19.00' RT.

150+91.21

17' W

NE 1/4 SEC. 33 T20N-R11W 2nd P.M.

COMBINATION CONCRETE CURB & GUTTER, TYPE B-6.24

FROM STATION	TO STATION	LT/RT	COMB CC&G TB6.24 (FT)	PROT COAT (SY)
WINTER AVENUE				
145+00.00	147+50.00	LT	252.5	84.2
145+00.00	147+50.00	RT	254.2	84.7
148+50.00	151+00.00	LT	251.4	83.9
148+50.00	151+00.00	RT	251.1	83.6
BOWMAN AVENUE				
60+00.00	61+41.19	LT	146.8	48.9
60+00.00	61+54.14	RT	170.7	56.9
62+26.78	63+50.00	LT	131.1	43.7
62+24.62	63+50.00	RT	138.0	46.0
SHEET TOTAL			1595.8	531.9

SEE DRAINAGE SHEETS FOR UNDERGROUND UTILITY LOCATIONS

SEE INTERSECTION DETAILS FOR HORIZONTAL CONTROL

SURVEY MARKER SCHEDULE

STATION	OFFSET	SURVEY MARKER VAULT (EACH)
147+93.05	0.00' RT.	1
SHEET TOTAL		
1		

PORTLAND CEMENT CONCRETE SIDEWALK SCHEDULE

FROM STATION	TO STATION	PC CONC SIDEWALK 5 INCH (SF)
245+00.00	247+14.55	2141.4
SHEET TOTAL		2141.4

REVISIONS	
NAME	DATE

CITY OF DANVILLE, ILLINOIS
WINTER AVENUE RECONSTRUCTION PROPOSED ROADWAY PLAN
 WINTER AVENUE/BOWMAN AVENUE
 STA. 145+00 TO STA. 151+00
 STA. 60+00 TO STA. 63+50
 SCALE: 1" = 20'
 DATE: 12/21/06
 DRAWN BY: NIL
 CHECKED BY: MBF

NW 1/4 SEC. 34 T20N-R11W 2nd P.M.

F.A.U. RTE.	SECTION	COUNTY	TOTAL SHEETS	SHEET NO.
6998	99-00209-01-PV	VERMILION	296	42
STA. 151+00		TO STA. 157+00		
FED. ROAD DIST. NO. ILLINOIS		FED. AID PROJECT-		
CONTRACT NO.: 91358				

SW 1/4 SEC. 27 T20N-R11W 2nd P.M.

CULVERT REMOVAL SCHEDULE

TYPE	FROM STATION	O/S	LT/RT	TO STATION	O/S	LT/RT	SIZE (IN)	PIPE CULVERT REMOV (FOOT) 50105220
RCCP	151+71.50	20.21'	LT	152+03.55	19.71'	LT	12	32.0
CMP	152+59.92	19.43'	LT	152+99.65	18.24'	LT	8	39.8
SHEET TOTAL								71.8

SIDEWALK REMOVAL SCHEDULE

FROM STATION	TO STATION	LT/RT	SIDEWALK REM (SF) 44000600
151+76.77	151+79.57	LT	17.2
SHEET TOTAL			17.2

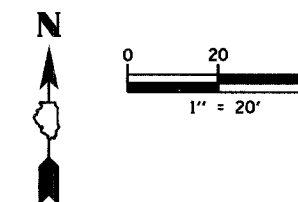

PLAN	SURVEYED	DATE
	BY	
	CHECKED	
	DATE	
	NO. OF WAYS CHECKED	
	DATE	
	FILE NAME	

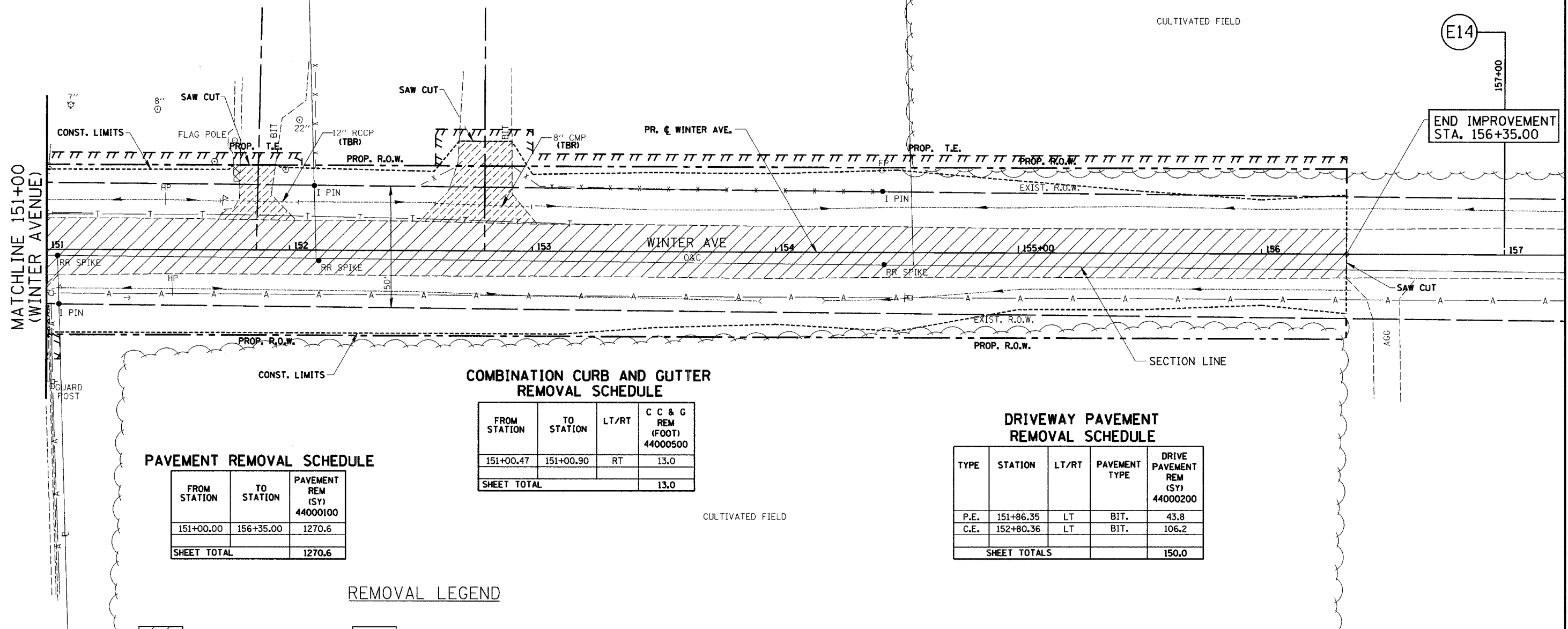

PAVEMENT REMOVAL SCHEDULE

FROM STATION	TO STATION	PAVEMENT REM (SY) 44000100
151+00.00	156+35.00	1270.6
SHEET TOTAL		1270.6

COMBINATION CURB AND GUTTER REMOVAL SCHEDULE

FROM STATION	TO STATION	LT/RT	C C & G REM (FOOT) 44000500
151+00.47	151+00.90	RT	13.0
SHEET TOTAL			13.0

DRIVEWAY PAVEMENT REMOVAL SCHEDULE

TYPE	STATION	LT/RT	PAVEMENT TYPE	DRIVE PAVEMENT REM (SY) 44000200
P.E.	151+86.35	LT	BIT.	43.8
C.E.	152+80.36	LT	BIT.	106.2
SHEET TOTALS				150.0

REMOVAL LEGEND

- PAVEMENT REMOVAL
- CURB & GUTTER REMOVAL
- TREE REMOVAL
- DRIVEWAY PAVEMENT REMOVAL
- GUARDRAIL REMOVAL
- TREE TRUNK PROTECTION
- SIDEWALK REMOVAL
- BITUMINOUS TAPER (FOR BUTT JOINTS)
- BUILDING REMOVAL
- TREE REMOVAL (AC)

NE 1/4 SEC. 33 T20N-R11W 2nd P.M.

REVISIONS	
NAME	DATE

CITY OF DANVILLE, ILLINOIS
WINTER AVENUE RECONSTRUCTION
 EXISTING REMOVAL
 WINTER AVENUE PLAN
 STA. 151+00 TO STA. 157+00

SCALE: 1" = 20' DATE: 12/21/06
 DRAWN BY: NIL CHECKED BY: MBF

NE 1/4 SEC. 33 T20N-R11W 2nd P.M.

F.A.U. RTE.	SECTION	COUNTY	TOTAL SHEETS	SHEET NO.
6998	99-00209-01-PV	VERMILION	296	45
STA. 54+00		TO STA. 60+00		
FED. ROAD DIST. NO. ILLINOIS		FED. AID PROJECT-		
CONTRACT NO.: 91358				

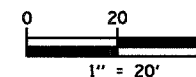

PLAN	DATE
SURVEYED	BY
PLANNED	BY
CHECKED	BY
NO. OF WAY CHECKED	
CARD FILE NAME	

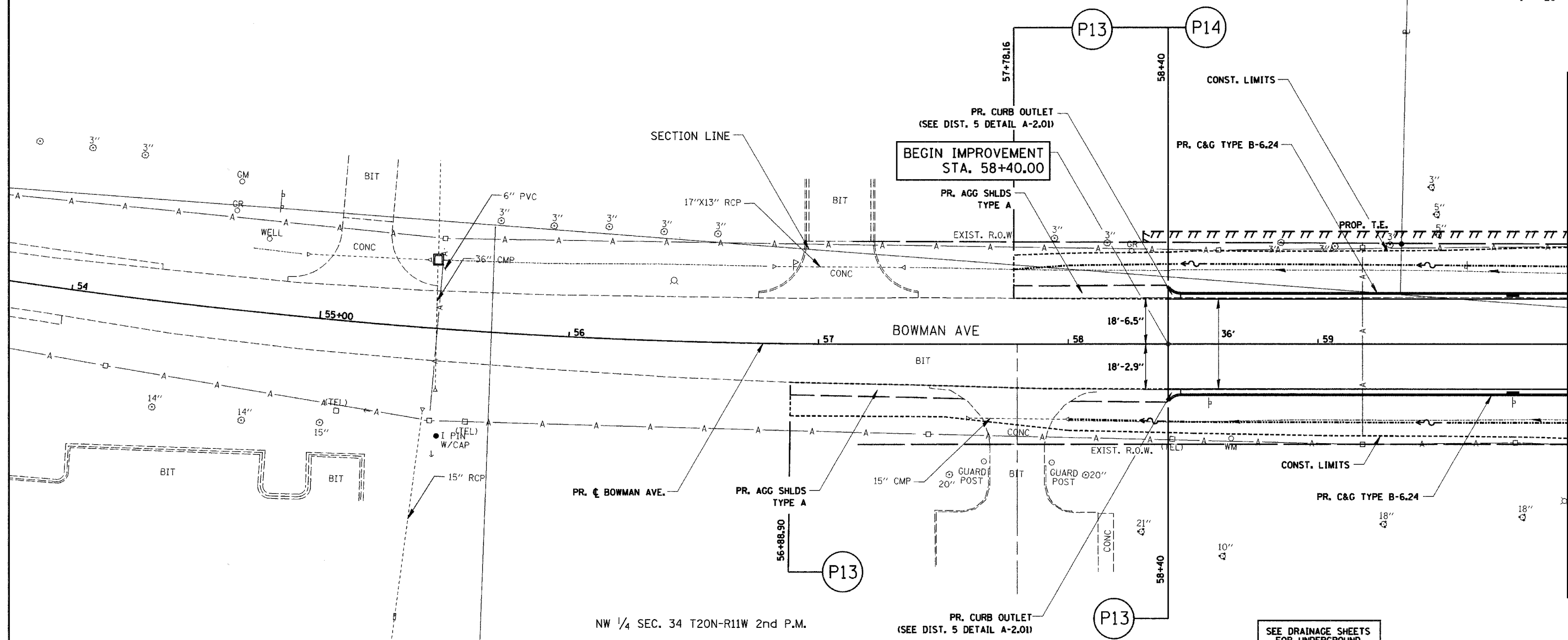

NW 1/4 SEC. 34 T20N-R11W 2nd P.M.

SEE DRAINAGE SHEETS FOR UNDERGROUND UTILITY LOCATIONS

AGGREGATE SHOULDERS, TYPE A

FROM STATION	TO STATION	LT/RT	AGG SHLDS TY A (TON) 48100100
56+88.90	57+59.13	RT	11.8
58+00.13	58+40.00	RT	6.3
57+78.16	58+40.00	LT	11.3
SHEET TOTAL			29.4

COMBINATION CONCRETE CURB & GUTTER, TYPE B-6.24

FROM STATION	TO STATION	LT/RT	COMB CC&G TB6.24 (FT) 60605000	PROT COAT (SY) 42001300
58+45.00	60+00.00	LT	155.0	51.7
58+45.00	60+00.00	RT	155.0	51.7
SHEET TOTAL			310.0	103.4

CLASS SI CONCRETE (OUTLET)

STATION	LT/RT	CLASS SI CONC OUTLET (CU YD) 60600095	PROT COAT (SY) 42001300
58+45.00	LT	0.56	2.3
58+45.00	RT	0.56	2.3
SHEET TOTAL		1.12	4.6

REVISIONS	
NAME	DATE

CITY OF DANVILLE, ILLINOIS
WINTER AVENUE RECONSTRUCTION
PROPOSED ROADWAY PLAN
BOWMAN AVENUE
 STA. 54+00 TO STA. 60+00

SCALE: 1" = 20'
 DRAWN BY: NIL
 DATE: 12/21/06
 CHECKED BY: MBF

F.A.J. RTE.	SECTION	COUNTY	TOTAL SHEETS	SHEET NO.
6998	99-00209-01-PV	VERMILION	296	46
STA. 63+50		TO STA. 69+50		
FED. ROAD DIST. NO. ILLINOIS		FED. AID PROJECT-		
CONTRACT NO.: 91358				

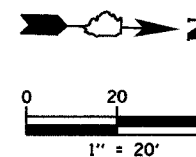

RAISED REFLECTIVE PAVEMENT MARKER REMOVAL SCHEDULE

FROM STATION	TO STATION	RAISED REF PVT MK REM (EACH) 78300200
69+02.93	69+50.00	4
SHEET TOTAL		4

PAVEMENT REMOVAL SCHEDULE

FROM STATION	TO STATION	PAVEMENT REM (SY) 44000100
63+50.00	69+02.93	1941.8
SHEET TOTAL		1941.8

SE 1/4 SEC. 28 T20N-R11W 2nd P.M.

CULVERT REMOVAL SCHEDULE

TYPE	FROM STATION	O/S	LT/RT	TO STATION	O/S	LT/RT	SIZE (IN)	PIPE CULVERT REMOV (FOOT) 50105220
CMP	64+03.50	30.90'	RT	64+58.60	29.52'	RT	15	55.1
CMP	64+43.73	32.45'	LT	64+74.46	32.01'	LT	15	30.7
CMP	67+15.70	28.68'	LT	67+47.82	28.76'	LT	15	32.1
CMP	67+42.30	69.59'	LT	67+62.68	57.89'	LT	12	23.5
CMP	68+59.13	25.47'	LT	69+01.46	25.14'	LT	15	42.3
SHEET TOTAL								183.7

TREE REMOVAL SCHEDULE (ACRES)

FROM STATION	TO STATION	LT/RT	TREE REMOV (ACRES) 20100500
65+75	65+97	LT	0.001
67+28	67+50	LT	0.005
SHEET TOTALS			0.006

DATE	
BY	
PLANNED	
NOTED	
CHECKED	
REVIEWED	
DATE	
BY	
PLANNED	
NOTED	
CHECKED	
REVIEWED	

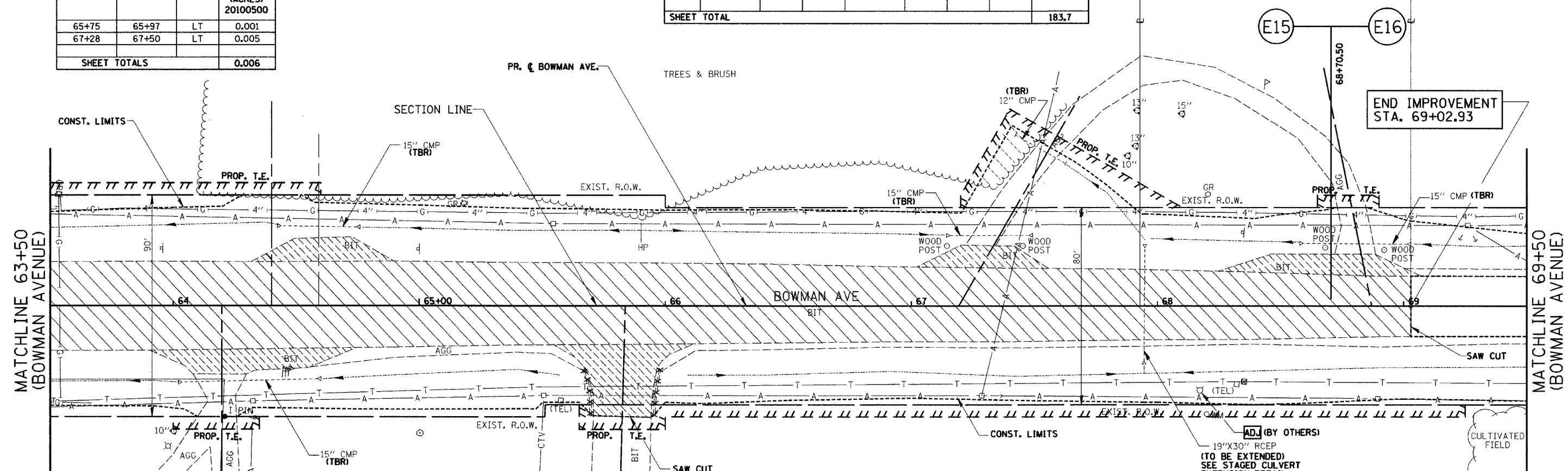

COMBINATION CURB AND GUTTER REMOVAL SCHEDULE

FROM STATION	TO STATION	LT/RT	C C & G REM (FOOT) 44000500
65+66.85	65+69.95	RT	19.3
65+95.16	65+97.70	RT	19.1
SHEET TOTAL			38.4

DRIVEWAY PAVEMENT REMOVAL SCHEDULE

TYPE	STATION	LT/RT	PAVEMENT TYPE	DRIVE PAVEMENT REM (SY) 44000200
P.E.	64+19.69	RT	BIT.	65.0
P.E.	64+59.00	LT	BIT.	44.0
C.E.	65+83.72	RT	BIT.	98.3
P.E.	67+19.20	LT	BIT.	38.2
P.E.	68+86.99	LT	BIT.	57.6
SHEET TOTALS				303.1

REMOVAL LEGEND

- PAVEMENT REMOVAL
- DRIVEWAY PAVEMENT REMOVAL
- SIDEWALK REMOVAL
- BUILDING REMOVAL
- CURB & GUTTER REMOVAL
- GUARDRAIL REMOVAL
- BITUMINOUS TAPER (FOR BUTT JOINTS)
- TREE REMOVAL (AC)
- TREE REMOVAL
- TREE TRUNK PROTECTION

SW 1/4 SEC. 27 T20N-R11W 2nd P.M.

REVISIONS	
NAME	DATE

CITY OF DANVILLE, ILLINOIS
WINTER AVENUE RECONSTRUCTION
EXISTING REMOVAL PLAN
BOWMAN AVENUE
STA. 63+50 TO STA. 69+50

SCALE: 1" = 20' DATE: 12/21/06
 DRAWN BY: NIL CHECKED BY: MBF

SE 1/4 SEC. 28 T20N-R11W 2nd P.M.

F.A.I. RTE.	SECTION	COUNTY	TOTAL SHEETS	SHEET NO.
6998	99-00209-01-PV	VERMILION	296	47
STA. 63+50		TO STA. 69+50		
FED. ROAD DIST. NO. ILLINOIS		FED. AID PROJECT-		

CONTRACT NO.: 91358

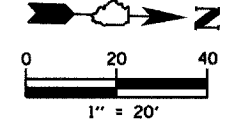

ENTRANCE QUANTITY SCHEDULE

TYPE	STATION	LT/RT	AGG BASE CSE B (CU YD)	AGG SURF CSE B (TONS)	BIT MATLS PR CT (GAL)	INCIDENTAL HMA SURF (TONS)	PCC DRIVEWAY PAVT 6 (SQ YD)	TEMP ACCESS-PRIV ENT (EACH)	TEMP ACCESS-COM ENT (EACH)
P.E.	64+19.69	RT	--	--	--	--	62.7	1	--
P.E.	64+40.00	LT	--	--	--	--	75.3	1	--
C.E.	65+83.72	RT	2.9	--	4.5	2.2	62.7	--	1
P.E.	67+19.20	LT	--	11.0	--	--	51.2	1	--
P.E.	68+86.99	LT	--	--	--	--	81.4	1	--
SHEET TOTALS			2.9	11.0	4.5	2.2	333.3	4	1

SEE ENTRANCE DETAILS FOR ENTRANCE DIMENSIONS

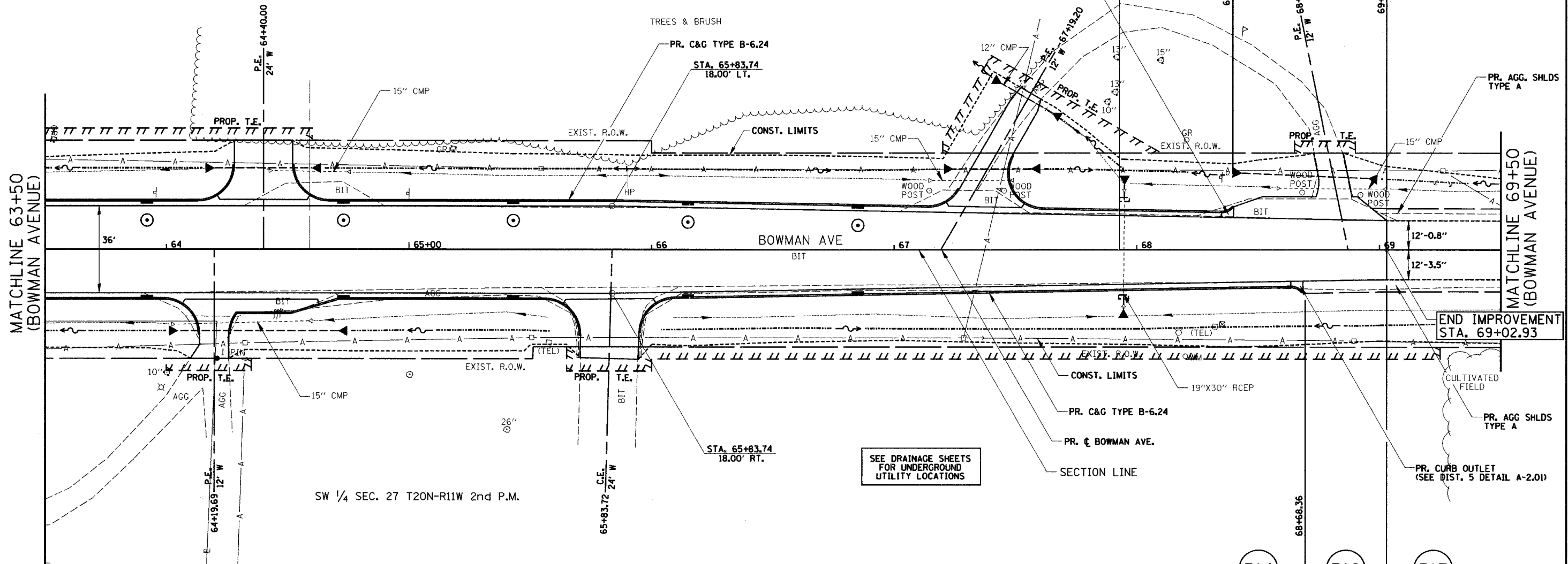

SEE DRAINAGE SHEETS FOR UNDERGROUND UTILITY LOCATIONS

AGGREGATE SHOULDERS, TYPE A

FROM STATION	TO STATION	LT/RT	AGG SHLDS TY A (TON)
68+68.36	69+50.00	RT	14.9
68+96.22	69+50.00	LT	9.3
SHEET TOTAL			24.2

COMBINATION CONCRETE CURB & GUTTER, TYPE B-6.24

FROM STATION	TO STATION	LT/RT	COMB CC&G TB6.24 (FT)	PROT COAT (SY)
63+50.00	68+34.82	LT	484.9	161.6
63+50.00	68+63.36	RT	513.4	171.1
SHEET TOTAL			998.3	332.7

CLASS SI CONCRETE (OUTLET)

STATION	LT/RT	CLASS SI CONC OUTLET (CU YD)	PROT COAT (SY)
68+34.82	LT	0.56	2.3
68+63.36	RT	0.56	2.3
SHEET TOTAL		1.12	4.6

REVISIONS	
NAME	DATE

CITY OF DANVILLE, ILLINOIS
**WINTER AVENUE RECONSTRUCTION
 PROPOSED ROADWAY PLAN
 BOWMAN AVENUE**
 STA. 63+50 TO STA. 69+50

SCALE: 1" = 20'
 DATE: 12/21/06
 DRAWN BY: NIL
 CHECKED BY: MBF

DATE	
BY	
PLANNED	
DESIGNED	
CHECKED	
IN CHARGE	
NO.	

SE 1/4 SEC. 28 T20N-R11W 2nd P.M.

F.A.I. RTE.	SECTION	COUNTY	TOTAL SHEETS	SHEET NO.
6998	99-00209-01-PV	VERMILION	296	48
STA. 69+50		TO STA. 75+50		
FED. ROAD DIST. NO. ILLINOIS		FED. AID PROJECT-		
CONTRACT NO.: 91358				

RAISED REFLECTIVE PAVEMENT MARKER REMOVAL SCHEDULE



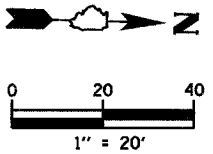



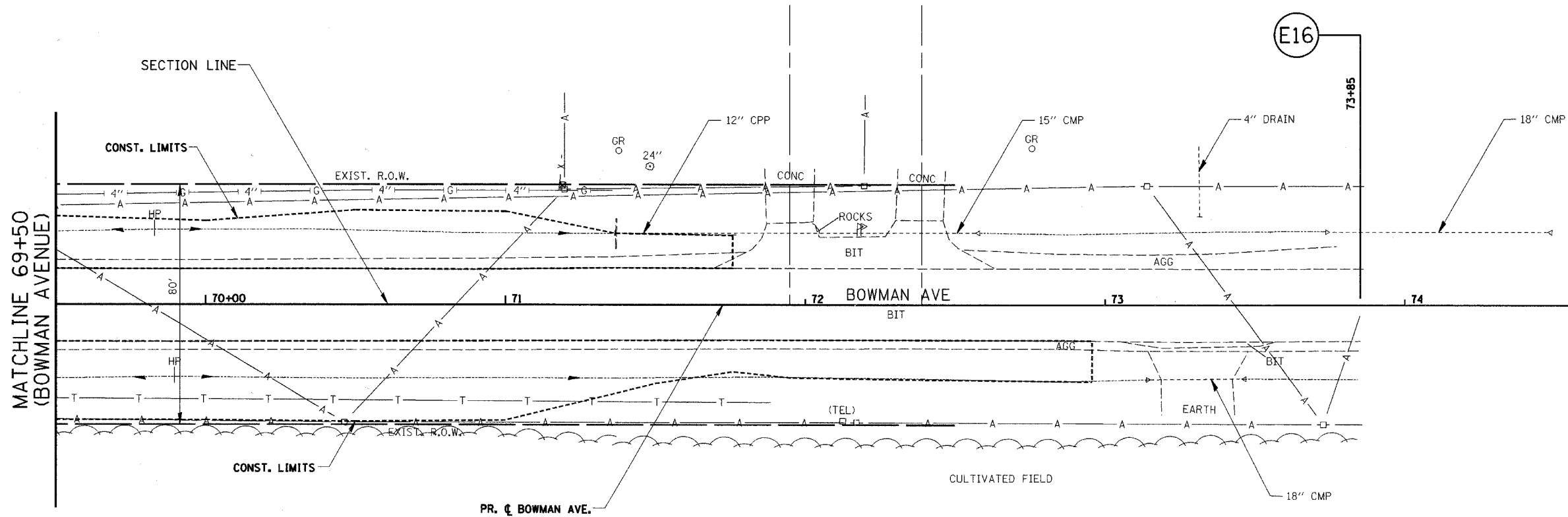



FROM STATION	TO STATION	RAISED REF PVT MK REM (EACH) 78300200
69+50.00	69+82.93	2
69+82.93	70+62.93	2
70+62.93	73+40.00	3
SHEET TOTAL		7



DATE	
BY	
REVISION	
NOTED	
ALIGNED	
CHECKED	
DATE	
FILE NAME	
NO.	



REMOVAL LEGEND

- | | | |
|---|--|---|
|  PAVEMENT REMOVAL |  CURB & GUTTER REMOVAL |  TREE REMOVAL |
|  DRIVEWAY PAVEMENT REMOVAL |  GUARDRAIL REMOVAL |  TREE TRUNK PROTECTION |
|  SIDEWALK REMOVAL |  BITUMINOUS TAPER (FOR BUTT JOINTS) | |
|  BUILDING REMOVAL |  TREE REMOVAL (AC) | |

SW 1/4 SEC. 27 T20N-R11W 2nd P.M.

REVISIONS	
NAME	DATE

CITY OF DANVILLE, ILLINOIS
WINTER AVENUE RECONSTRUCTION
EXISTING REMOVAL PLAN
BOWMAN AVENUE
STA. 69+50 TO STA. 75+50

SCALE: 1" = 20'
 DATE: 12/21/06
 DRAWN BY: NIL
 CHECKED BY: MBF

SE 1/4 SEC. 28 T20N-R11W 2nd P.M.

F.A.D. RTE.	SECTION	COUNTY	TOTAL SHEETS	SHEET NO.
6998	99-00209-01-PV	VERMILION	296	49
STA. 69+50		TO STA. 75+50		
FED. ROAD DIST. NO. ILLINOIS		FED. AID PROJECT-		

CONTRACT NO.: 91358

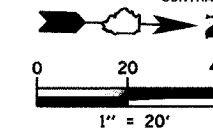

PLAN	SURVEYED	DATE
NOTE BOOK	ALIGNED	BY
NO.	RT. OF WAY CHECKED	
	ROAD FILE NAME	

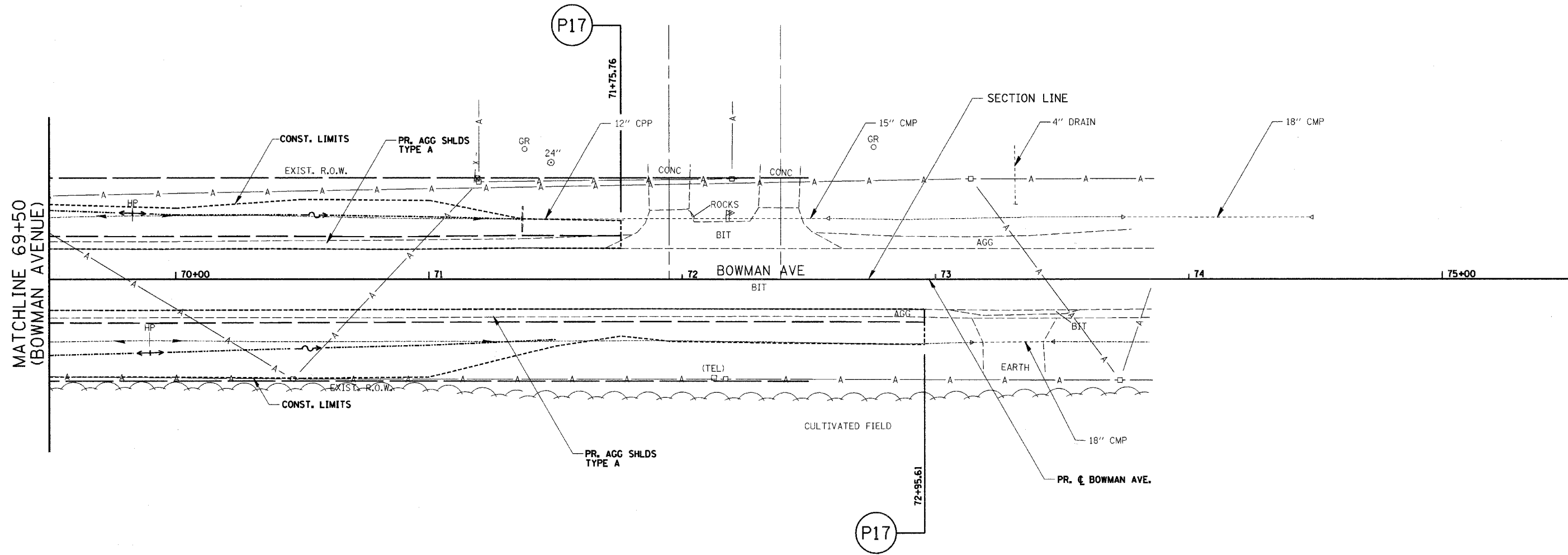

AGGREGATE SHOULDERS, TYPE A

FROM STATION	TO STATION	LT/RT	AGG SHLDS TY A (TON) 48100100
69+50.00	72+95.61	RT	63.4
69+50.00	71+75.76	LT	41.1
SHEET TOTAL			104.5

SEE DRAINAGE SHEETS FOR UNDERGROUND UTILITY LOCATIONS

SW 1/4 SEC. 27 T20N-R11W 2nd P.M.

REVISIONS	
NAME	DATE

CITY OF DANVILLE, ILLINOIS
**WINTER AVENUE RECONSTRUCTION
 PROPOSED ROADWAY PLAN
 BOWMAN AVENUE
 STA. 69+50 TO STA. 75+50**

SCALE: 1" = 20'
 DATE: 12/21/06
 DRAWN BY: NIL
 CHECKED BY: MBF

F.A.U. RTE.	SECTION	COUNTY	TOTAL SHEETS	SHEET NO.
6998	99-00209-01-PV	VERMILION	296	50
STA. 97+00		TO STA. 109+00		
FED. ROAD DIST. NO. ILLINOIS		FED. AID PROJECT-		
CONTRACT NO.: 91358				

SSD = 223'
K = 33
150.00' V.C.VPI STA. 102+57.50
ELEVATION 618.14

DATE	
BY	
PROFILER	
PLOTTED	
CHECKED	
DATE	
BY	
NOTE BOOK NO.	
STRUCTURE NOTATION	
DATE	
BY	
PROFILER	
PLOTTED	
CHECKED	
DATE	
BY	
NOTE BOOK NO.	
STRUCTURE NOTATION	

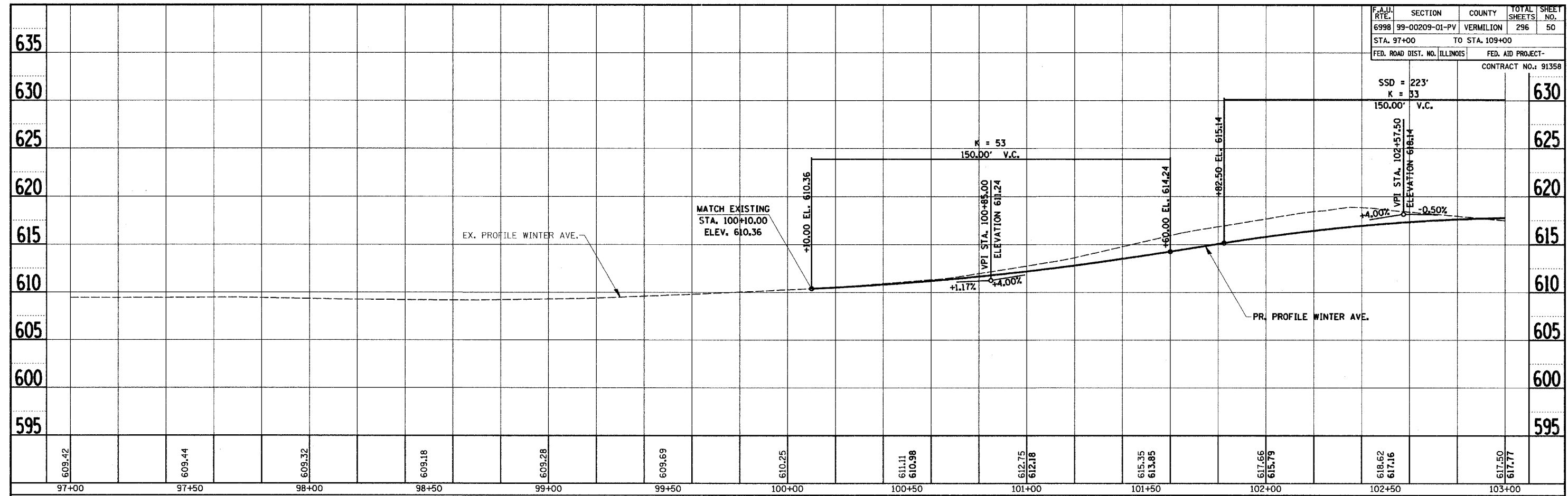

DATE	
BY	
PROFILER	
PLOTTED	
CHECKED	
DATE	
BY	
NOTE BOOK NO.	
STRUCTURE NOTATION	
DATE	
BY	
PROFILER	
PLOTTED	
CHECKED	
DATE	
BY	
NOTE BOOK NO.	
STRUCTURE NOTATION	

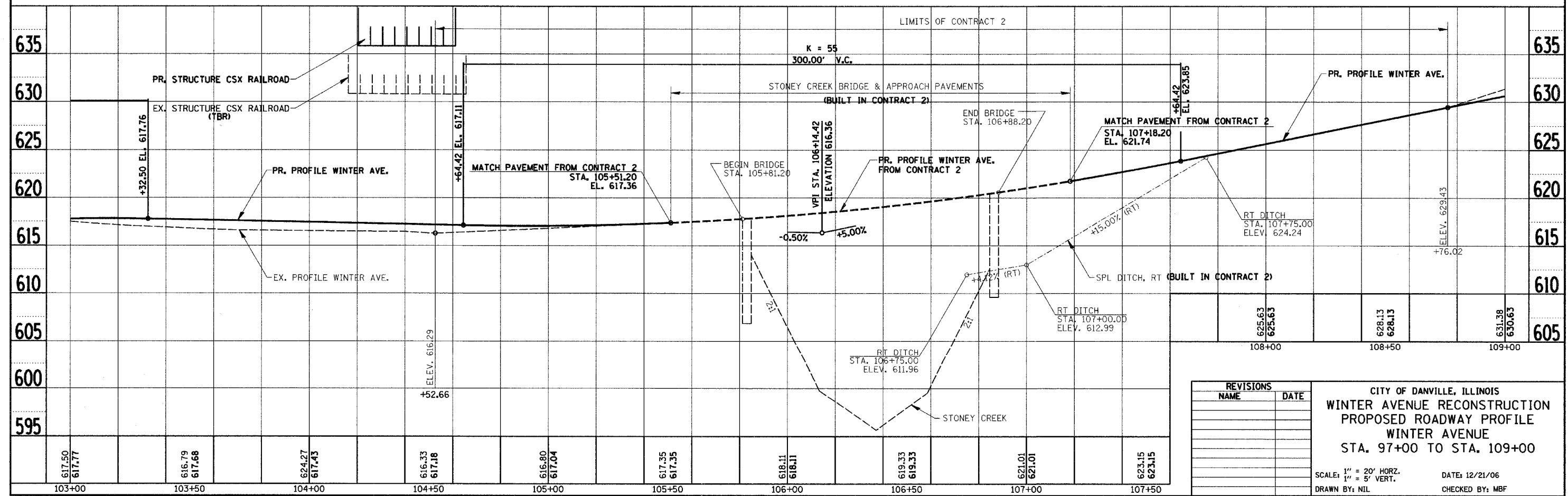

REVISIONS	
NAME	DATE

CITY OF DANVILLE, ILLINOIS
WINTER AVENUE RECONSTRUCTION
PROPOSED ROADWAY PROFILE
WINTER AVENUE
STA. 97+00 TO STA. 109+00

SCALE: 1" = 20' HORIZ.
1" = 5' VERT.

DATE: 12/21/06
DRAWN BY: NIL
CHECKED BY: MBF

F.A.I. RTE.	SECTION	COUNTY	TOTAL SHEETS	SHEET NO.
6998	99-00209-01-PV	VERMILION	296	51
STA. 109+00		TO STA. 121+00		
FED. ROAD DIST. NO. ILLINOIS		FED. AID PROJECT-		
CONTRACT NO.: 91358				

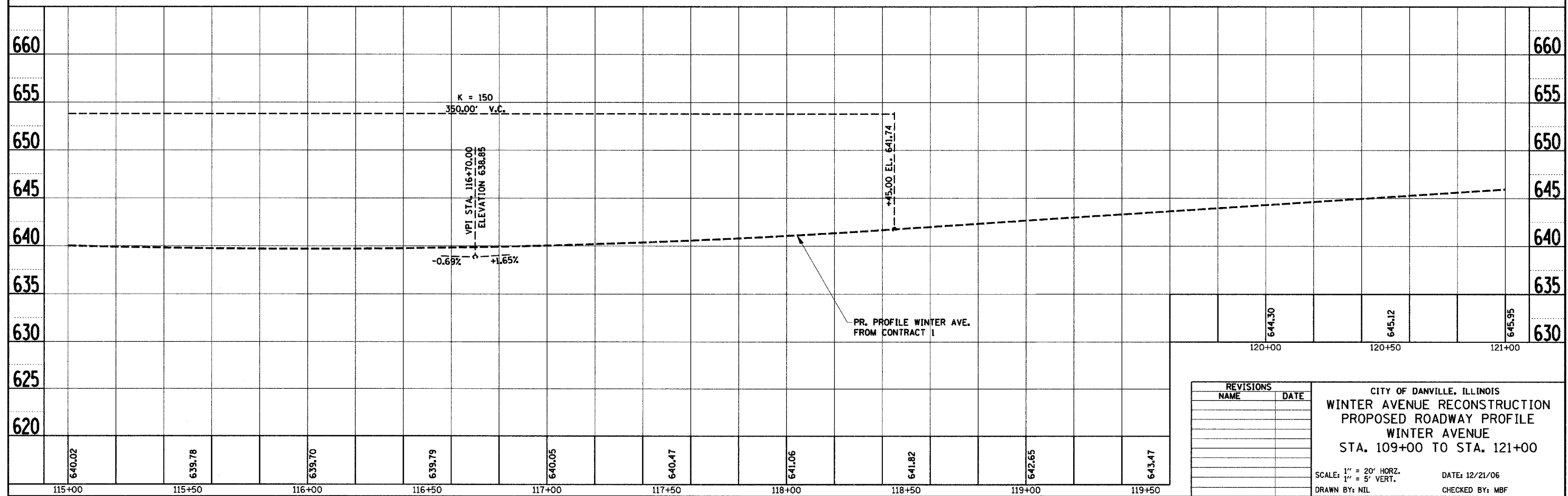
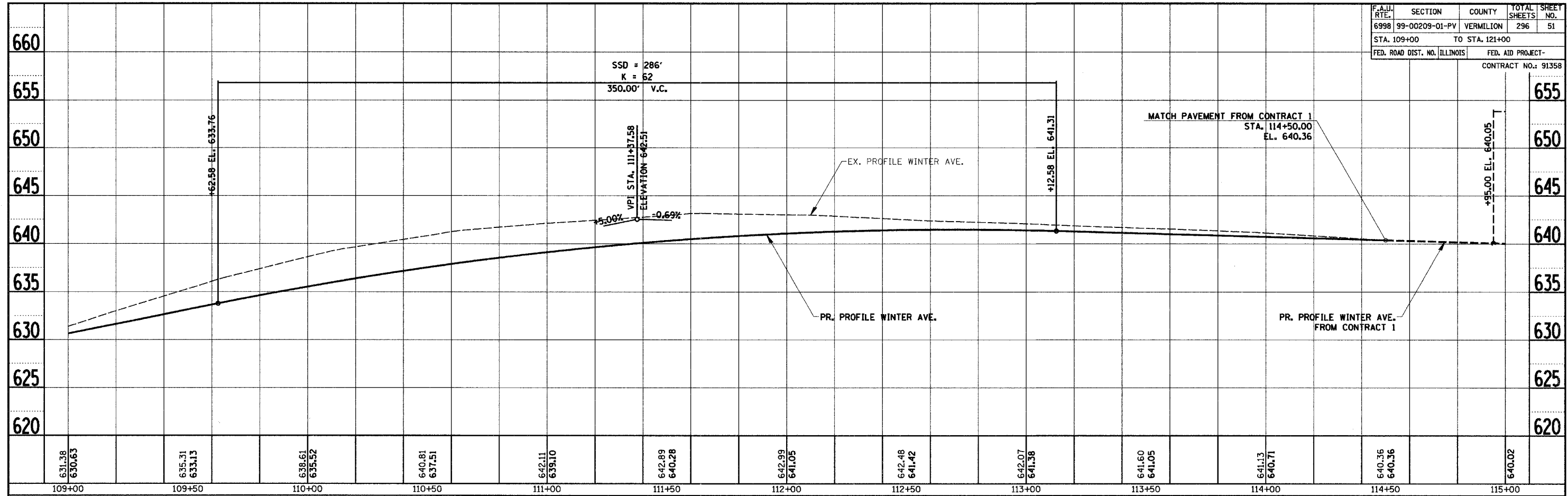

DATE	
BY	
PROFILER	
CHECKER	
DATE	
BY	
NOTE BOOK	
NO.	

DATE	
BY	
PROFILER	
CHECKER	
DATE	
BY	
NOTE BOOK	
NO.	

REVISIONS		DATE
NAME		

CITY OF DANVILLE, ILLINOIS
WINTER AVENUE RECONSTRUCTION
PROPOSED ROADWAY PROFILE
WINTER AVENUE
STA. 109+00 TO STA. 121+00

SCALE: 1" = 20' HORZ.
1" = 5' VERT.

DATE: 12/21/06
DRAWN BY: NIL
CHECKED BY: MBF

F.A.U. RTE.	SECTION	COUNTY	TOTAL SHEETS	SHEET NO.
6998	99-00209-01-PV	VERMILION	296	52
STA. 133+00		TO STA. 145+00		
FED. ROAD DIST. NO. ILLINOIS		FED. AID PROJECT-		
CONTRACT NO.: 91358				

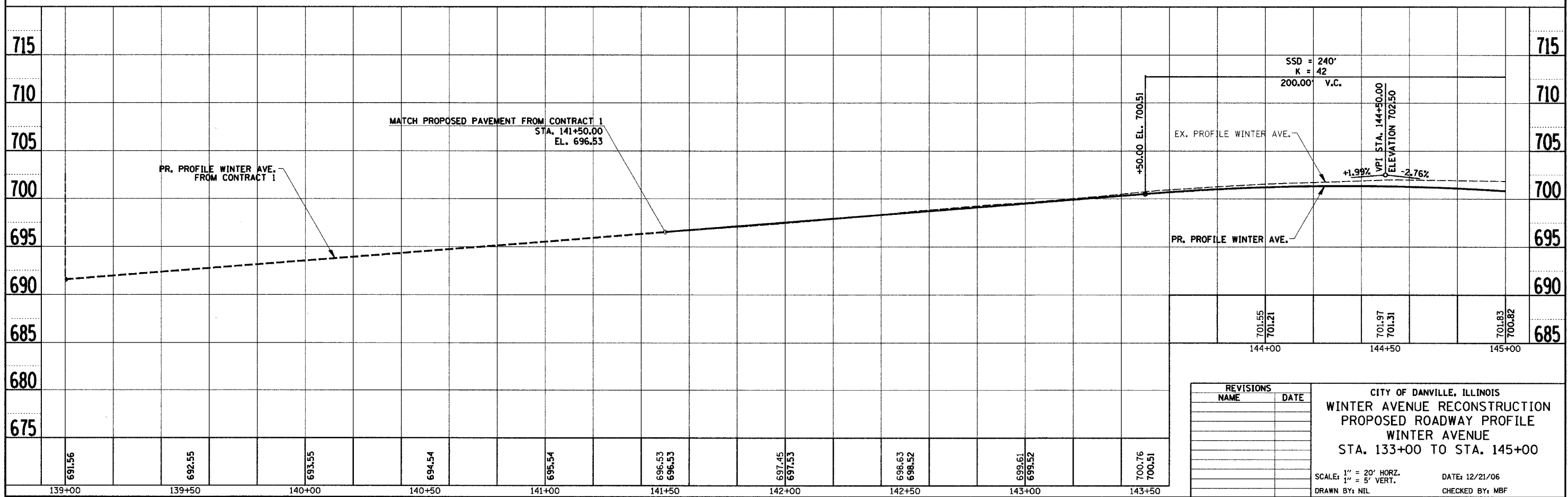
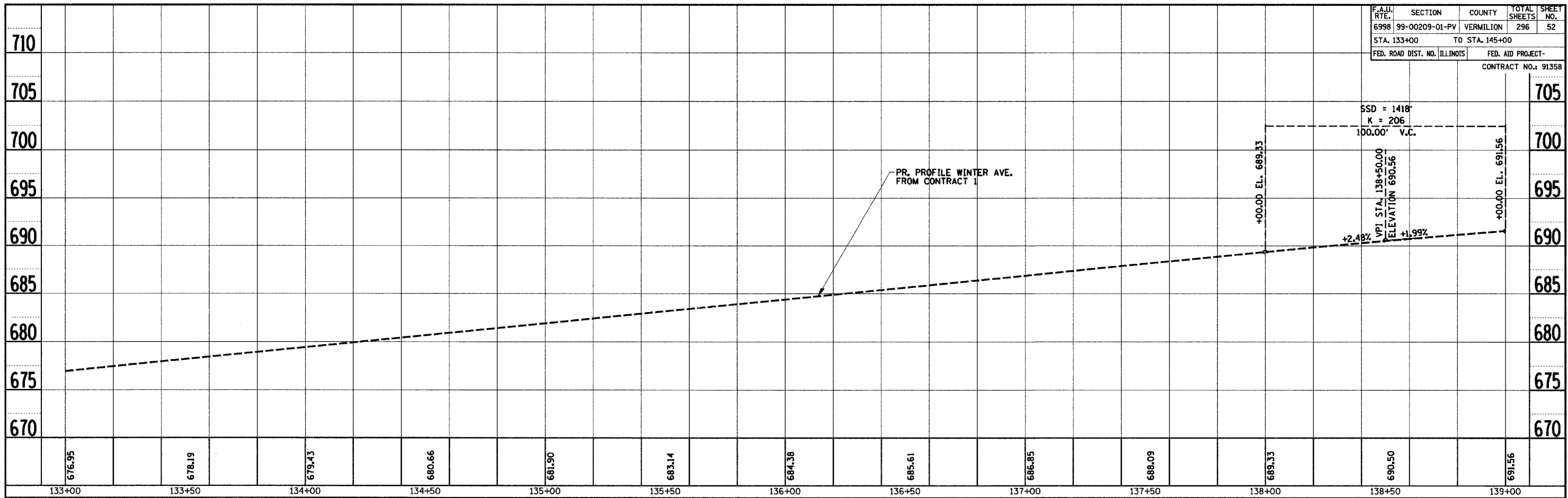

PROFILE SURVEYED BY: _____ DATE: _____
 PLOTTED BY: _____
 CHECKED BY: _____
 NOTE BOOK NO.: _____
 STRUCTURE NOTATION: _____

PROFILE SURVEYED BY: _____ DATE: _____
 PLOTTED BY: _____
 CHECKED BY: _____
 NOTE BOOK NO.: _____
 STRUCTURE NOTATION: _____

REVISIONS	
NAME	DATE

CITY OF DANVILLE, ILLINOIS
 WINTER AVENUE RECONSTRUCTION
 PROPOSED ROADWAY PROFILE
 WINTER AVENUE
 STA. 133+00 TO STA. 145+00

SCALE: 1" = 20' HORIZ.
 1" = 5' VERT.
 DRAWN BY: NIL
 DATE: 12/21/06
 CHECKED BY: MBF

F.A.J. RTE.	SECTION	COUNTY	TOTAL SHEETS	SHEET NO.
6998	99-00209-01-PV	VERMILION	296	53
STA. 145+00		TO STA. 157+00		
FED. ROAD DIST. NO. ILLINOIS		FED. AID PROJECT-		
CONTRACT NO.: 91358				

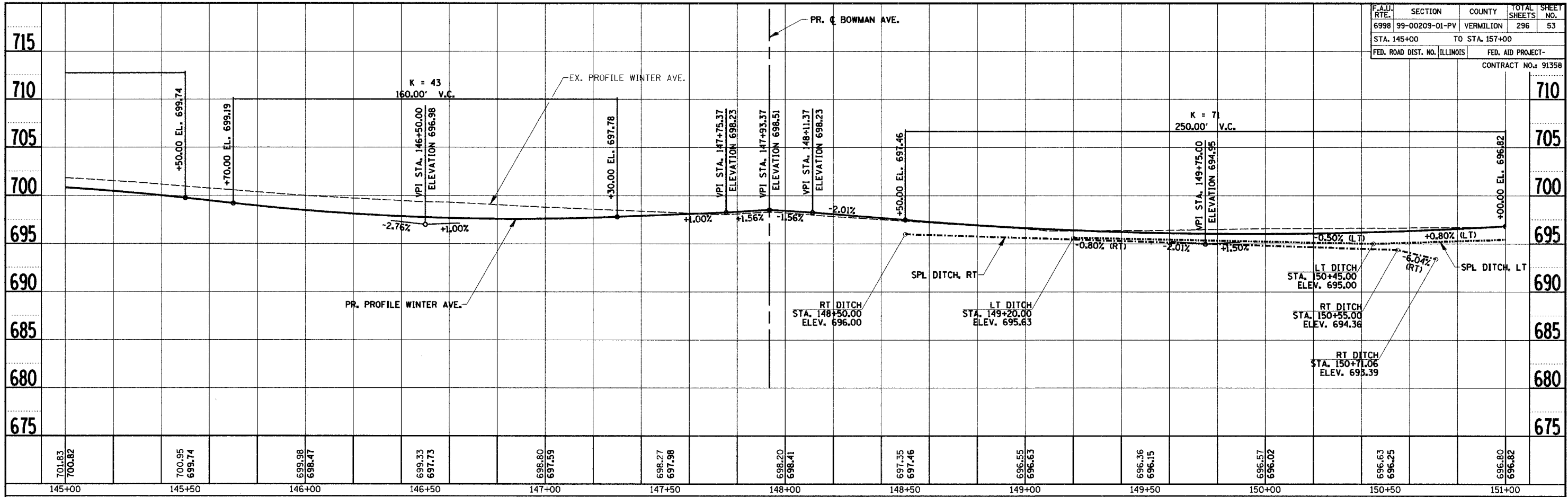

PROFILE SURVEYED	BY	DATE
DESIGNED		
CHECKED		
NOTE BOOK		
NO.		
STRUCTURE NOTATING CARD		

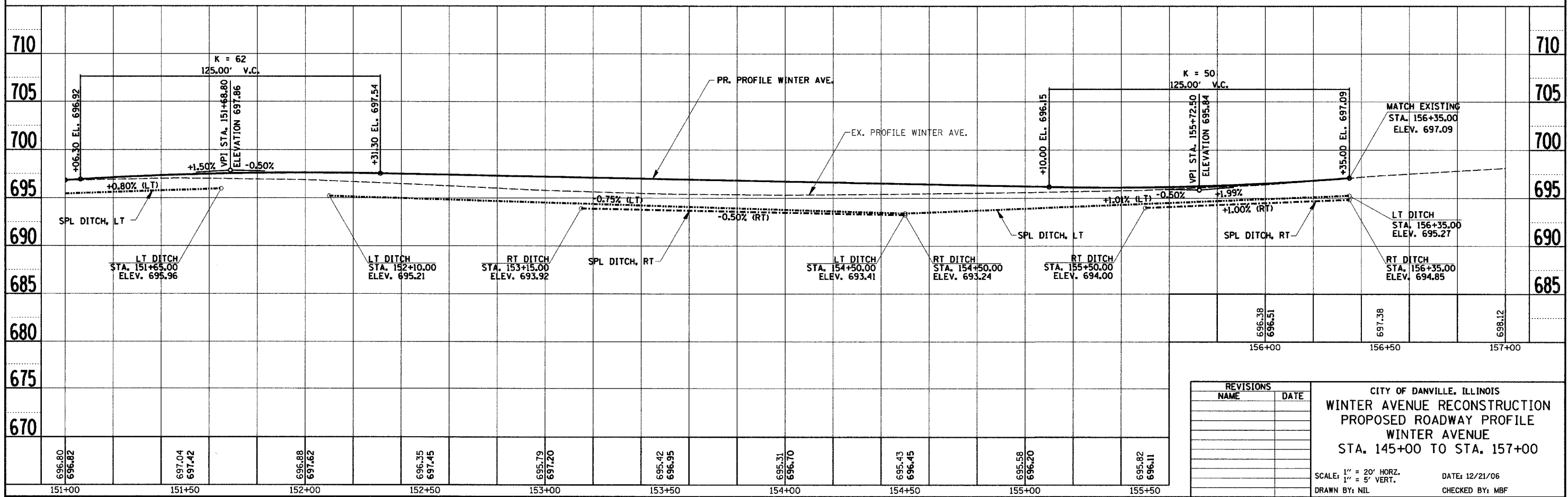

PROFILE SURVEYED	BY	DATE
DESIGNED		
CHECKED		
NOTE BOOK		
NO.		
STRUCTURE NOTATING CARD		

REVISIONS	
NAME	DATE

CITY OF DANVILLE, ILLINOIS
WINTER AVENUE RECONSTRUCTION
PROPOSED ROADWAY PROFILE
WINTER AVENUE
STA. 145+00 TO STA. 157+00

SCALE: 1" = 20' HORZ.
1" = 5' VERT.

DATE: 12/21/06
DRAWN BY: NIL
CHECKED BY: MBF

F.A.I. RTE.	SECTION	COUNTY	TOTAL SHEETS	SHEET NO.
6998	99-00209-01-PV	VERMILION	296	54
STA. 56+00		TO STA. 68+00		
FED. ROAD DIST. NO. ILLINOIS		FED. AID PROJECT-		
PR. WINTER AVE.		CONTRACT NO. 91358		

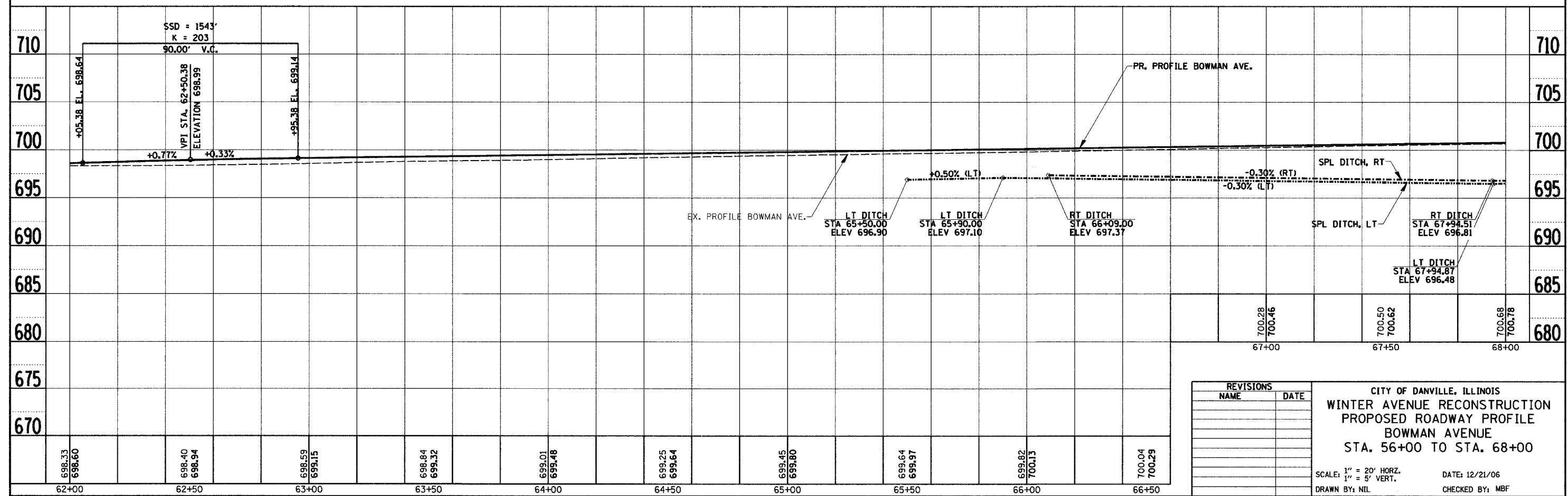
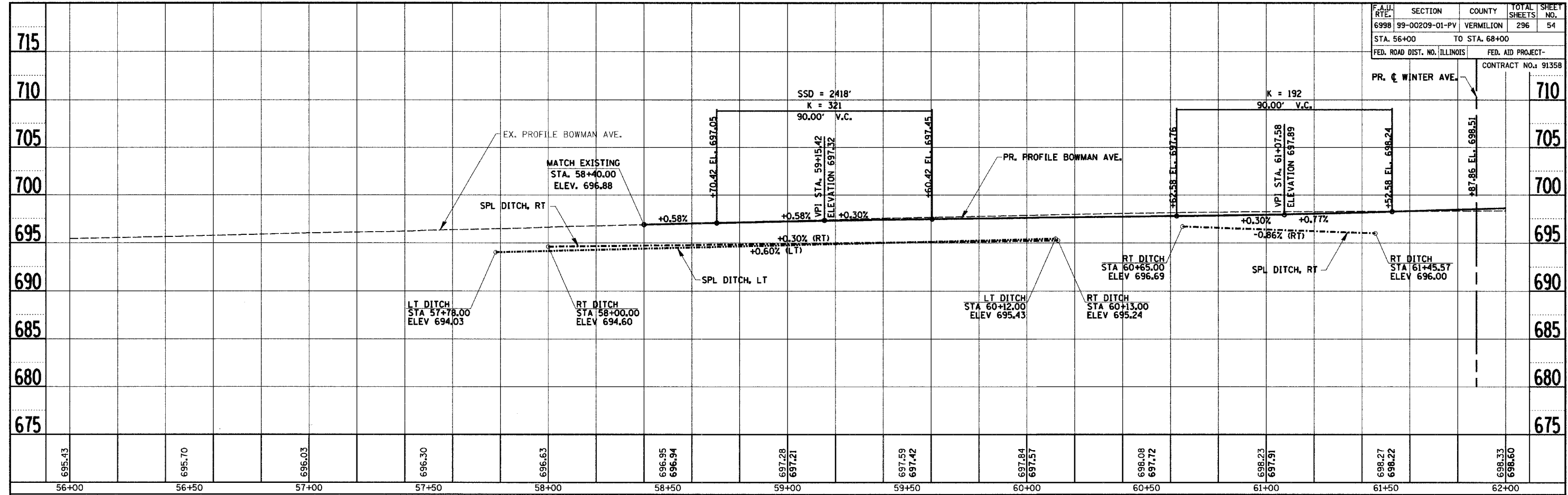

PROFILE SURVEYED BY DATE
 PLOTTED BY DATE
 CHECKED BY DATE
 NOTE BOOK NO.
 STRUCTURE NOTATING CIRCD NO.

PROFILE SURVEYED BY DATE
 PLOTTED BY DATE
 CHECKED BY DATE
 NOTE BOOK NO.
 STRUCTURE NOTATING CIRCD NO.

REVISIONS	
NAME	DATE

CITY OF DANVILLE, ILLINOIS
 WINTER AVENUE RECONSTRUCTION
 PROPOSED ROADWAY PROFILE
 BOWMAN AVENUE
 STA. 56+00 TO STA. 68+00

SCALE: 1" = 20' HORIZ.
 1" = 5' VERT.

DATE: 12/21/06
 DRAWN BY: NIL
 CHECKED BY: MBF

F.A.J. RTE.	SECTION	COUNTY	TOTAL SHEETS	SHEET NO.
6998	99-00209-01-PV	VERMILION	296	55
STA. 68+00		TO STA. 74+00		
FED. ROAD DIST. NO. ILLINOIS		FED. AID PROJECT-		
CONTRACT NO.: 91358				

PROFILE SURVEYED	DATE
PLANS CHECKED	BY
B.M. NOTED	
STRUCTURE NOTATING OK'D	
NOTE BOOK NO.	

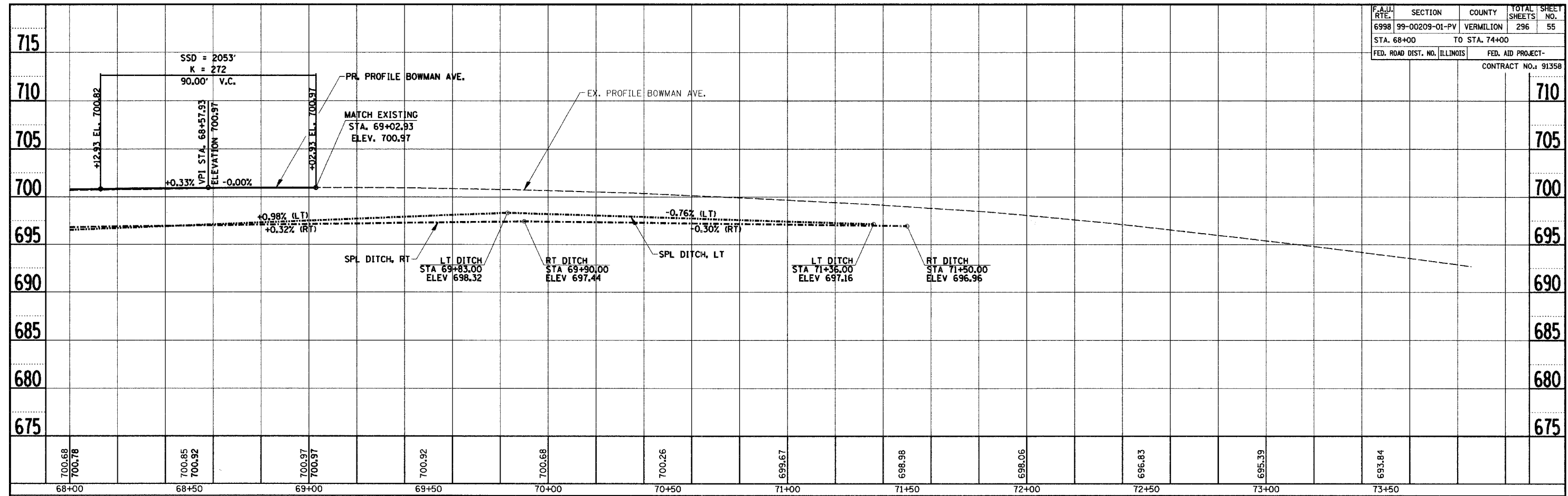

PROFILE SURVEYED	DATE
PLANS CHECKED	BY
B.M. NOTED	
STRUCTURE NOTATING OK'D	
NOTE BOOK NO.	

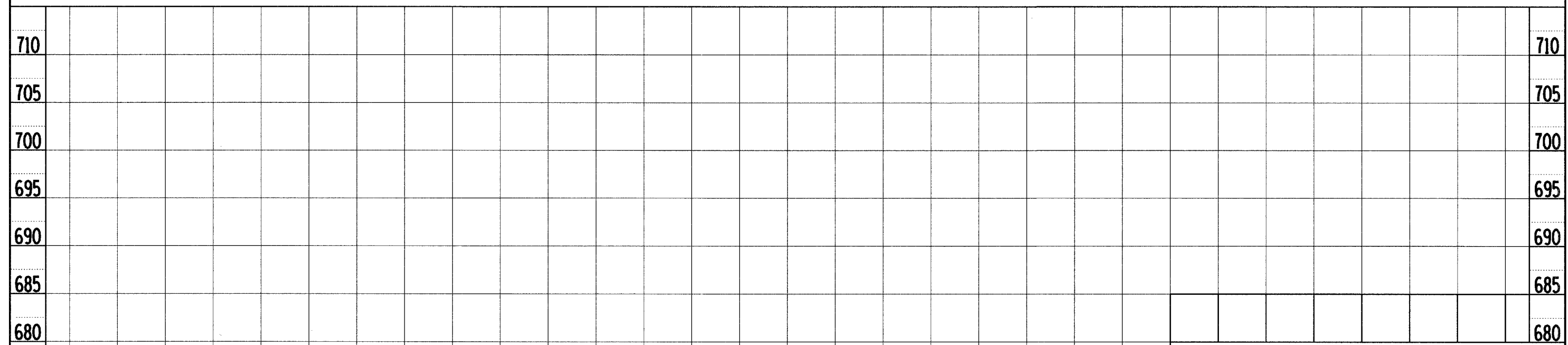

REVISIONS	
NAME	DATE

CITY OF DANVILLE, ILLINOIS
WINTER AVENUE RECONSTRUCTION
PROPOSED ROADWAY PROFILE
BOWMAN AVENUE
STA. 68+00 TO STA. 74+00

SCALE: 1" = 20' HORIZ.
1" = 5' VERT.
DRAWN BY: NIL
DATE: 12/21/06
CHECKED BY: MRF

F.A.J. RTE.	SECTION	COUNTY	TOTAL SHEETS	SHEET NO.
6998	99-00209-01-PV	VERMILION	296	56
STA. 199+50		TO STA. 209+00		
FED. ROAD DIST. NO. ILLINOIS		FED. AID PROJECT-		
CONTRACT NO.: 91358				

PROFILE	SURVEYED	DATE
NOTE BOOK	DESIGNED	
NO.	CHECKED	
	BY	
	DATE	
	NO.	
	DATE	
	BY	
	DATE	
	NO.	
	DATE	
	BY	
	DATE	
	NO.	

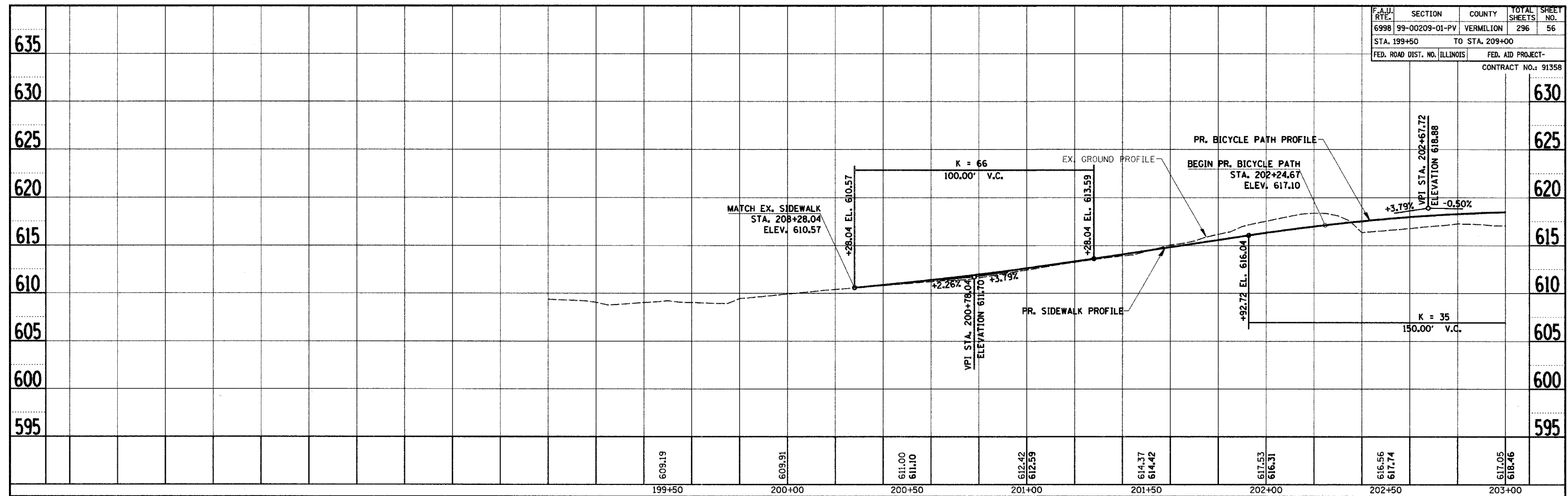

PROFILE	SURVEYED	DATE
NOTE BOOK	DESIGNED	
NO.	CHECKED	
	BY	
	DATE	
	NO.	
	DATE	
	BY	
	DATE	
	NO.	

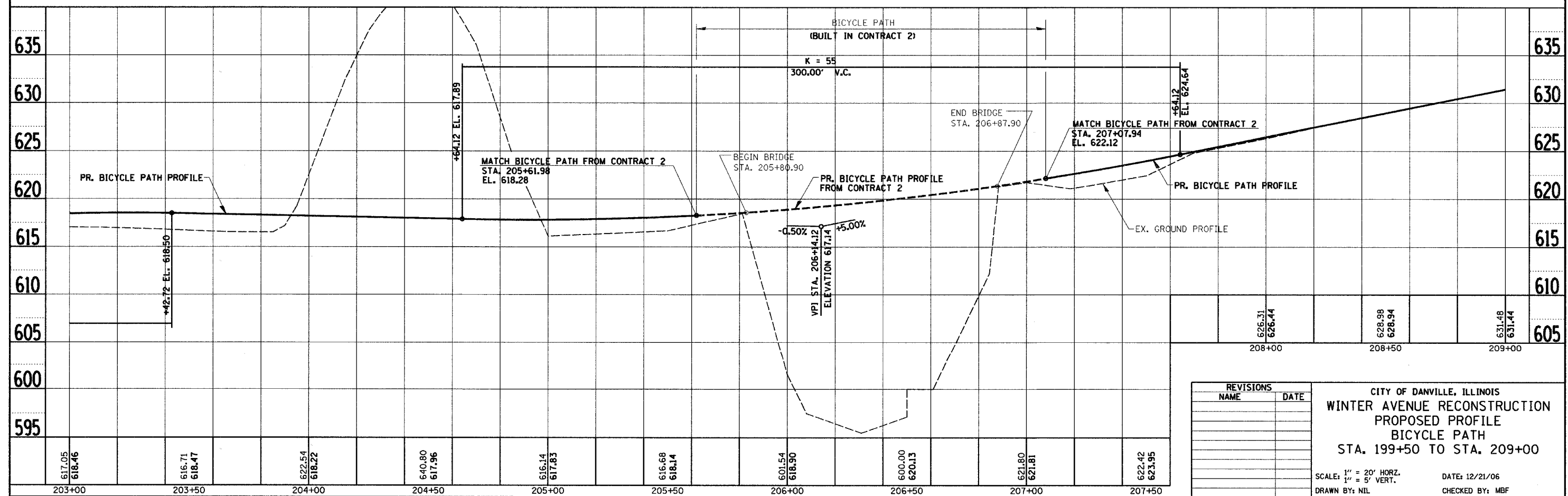

REVISIONS	
NAME	DATE

CITY OF DANVILLE, ILLINOIS
WINTER AVENUE RECONSTRUCTION
PROPOSED PROFILE
BICYCLE PATH
STA. 199+50 TO STA. 209+00

SCALE: 1" = 20' HORIZ.
1" = 5' VERT.
DRAWN BY: NIL
DATE: 12/21/06
CHECKED BY: MBF

F.A.U. RTE.	SECTION	COUNTY	TOTAL SHEETS	SHEET NO.
6998	99-00209-01-PV	VERMILION	296	57
STA. 209+00		TO STA. 221+00		
FED. ROAD DIST. NO. ILLINOIS		FED. AID PROJECT-		

CONTRACT NO.: 91358

MATCH BICYCLE PATH FROM CONTRACT 1
STA. 214+50.00
EL. 641.05

+95.00 EL. 640.74

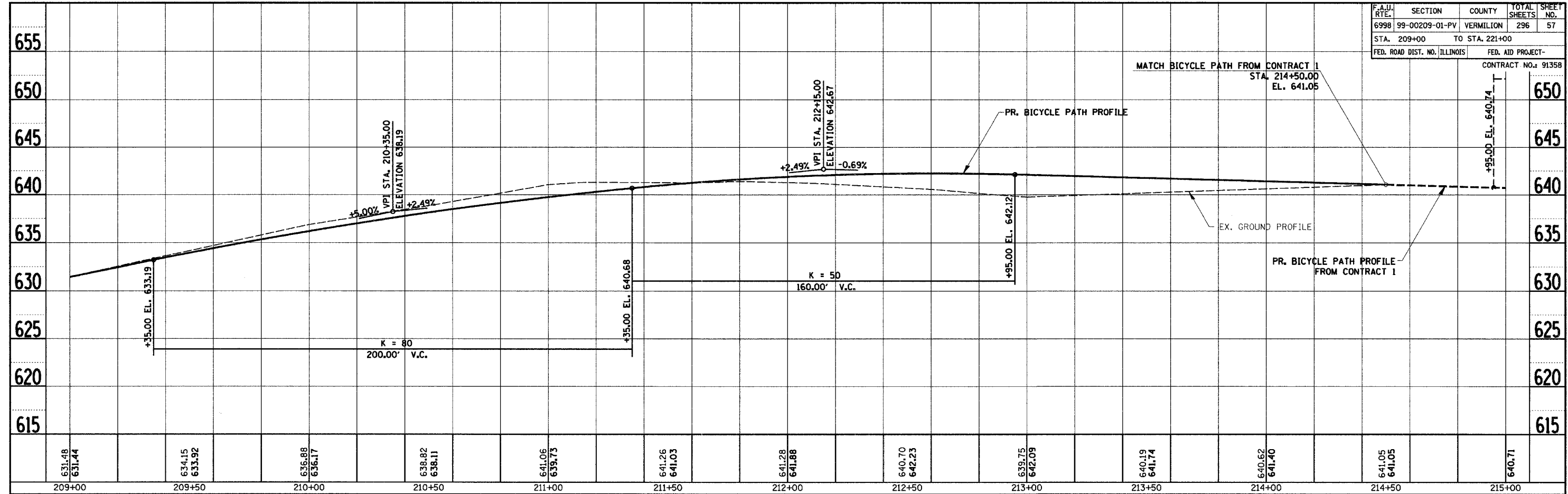

PROFILE SURVEYED BY: _____ DATE: _____
 PLAN CHECKED BY: _____
 NOTE BOOK NO.: _____
 STRUCTURE NOTATING DPKD NO.: _____

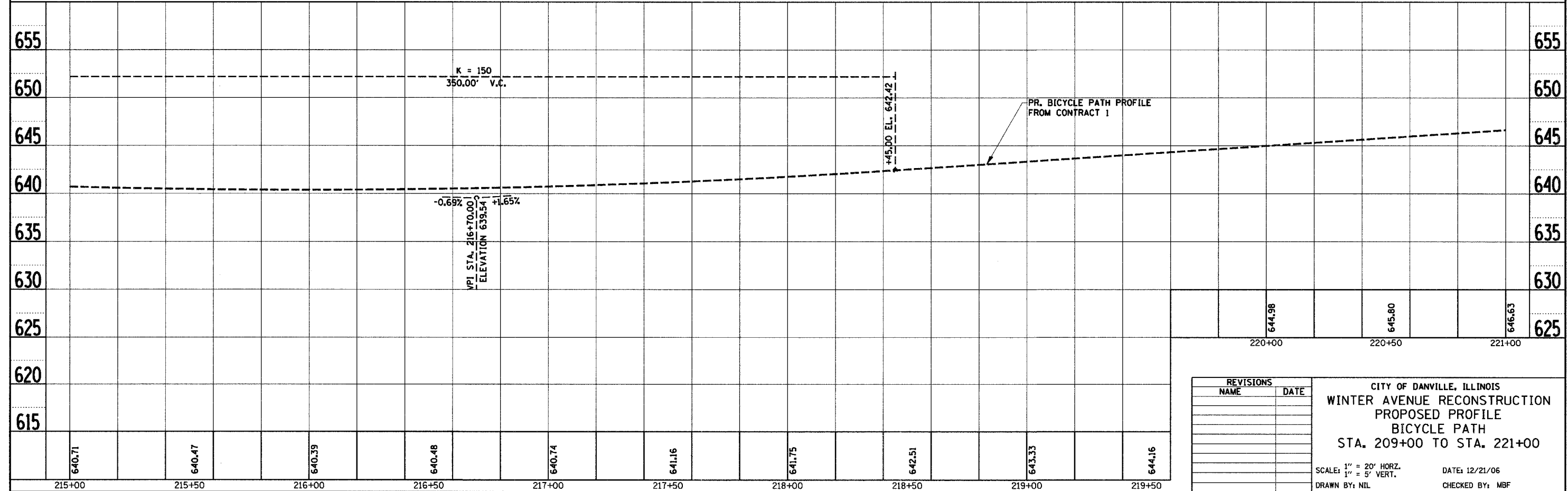

PROFILE SURVEYED BY: _____ DATE: _____
 PLAN CHECKED BY: _____
 NOTE BOOK NO.: _____
 STRUCTURE NOTATING DPKD NO.: _____

REVISIONS	
NAME	DATE

CITY OF DANVILLE, ILLINOIS
 WINTER AVENUE RECONSTRUCTION
 PROPOSED PROFILE
 BICYCLE PATH
 STA. 209+00 TO STA. 221+00

SCALE: 1" = 20' HORZ.
 1" = 5' VERT.
 DRAWN BY: NIL
 DATE: 12/21/06
 CHECKED BY: MBF

F.A.U. RTE.	SECTION	COUNTY	TOTAL SHEETS	SHEET NO.
6998	99-00209-01-PV	VERMILION	296	58
STA. STA. 233+00		TO STA. STA. 245+00		
FED. ROAD DIST. NO. ILLINOIS		FED. AID PROJECT-		
CONTRACT NO.: 91358				

PROFILE SURVEYED BY: _____ DATE: _____
 PLOTTED BY: _____
 CHECKED BY: _____
 NOTE BOOK NO. _____
 STRUCTURE NOTATION CRKD NO. _____

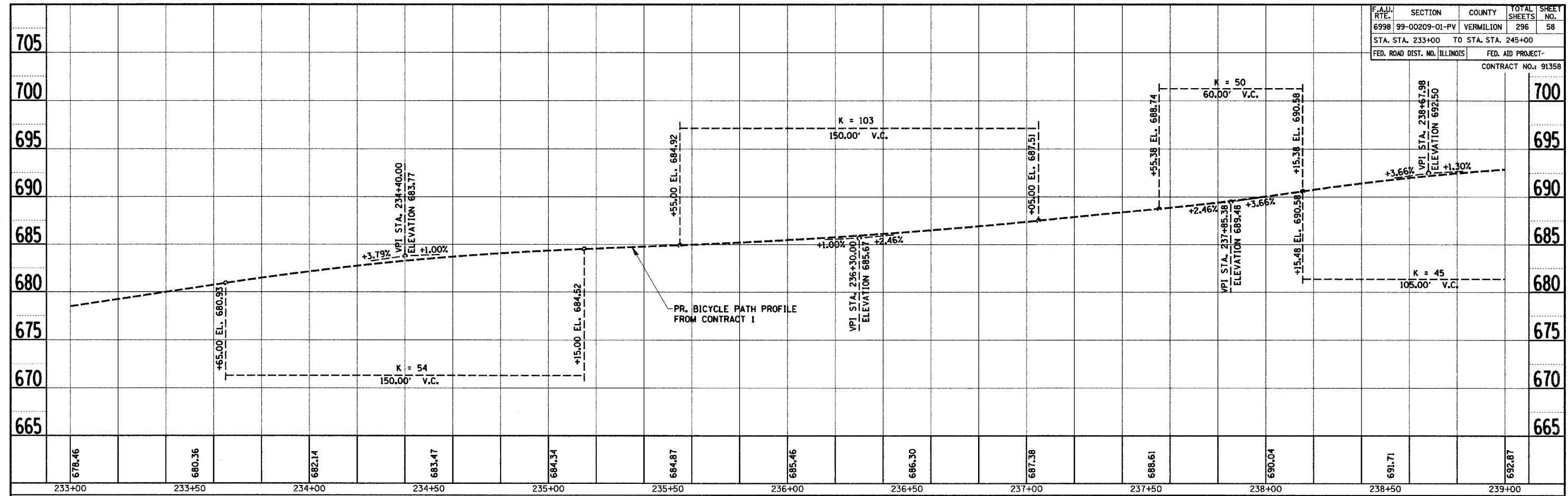

PROFILE SURVEYED BY: _____ DATE: _____
 PLOTTED BY: _____
 CHECKED BY: _____
 NOTE BOOK NO. _____
 STRUCTURE NOTATION CRKD NO. _____

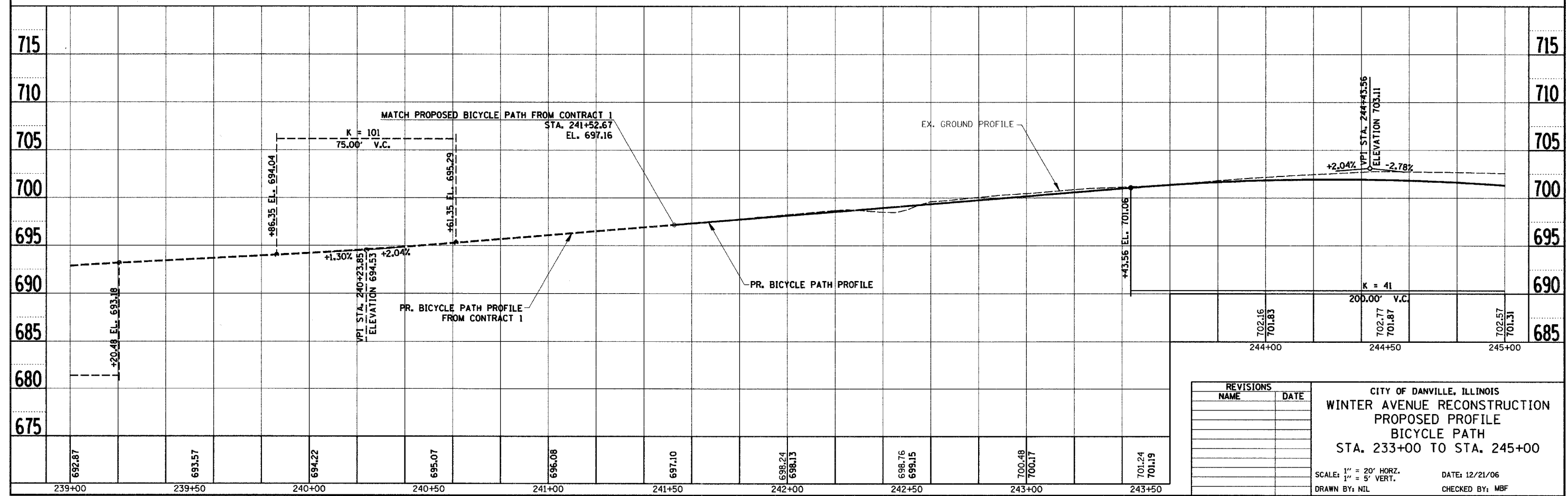

REVISIONS	
NAME	DATE

CITY OF DANVILLE, ILLINOIS
 WINTER AVENUE RECONSTRUCTION
 PROPOSED PROFILE
 BICYCLE PATH
 STA. 233+00 TO STA. 245+00

SCALE: 1" = 20' HORIZ.
 1" = 5' VERT.

DATE: 12/21/06
 DRAWN BY: NIL
 CHECKED BY: MBF

F.A.U. RTE.	SECTION	COUNTY	TOTAL SHEETS	SHEET NO.
6998	99-00209-01-PV	VERMILION	296	59
STA. 245+00		TO STA. 248+50		
FED. ROAD DIST. NO. ILLINOIS		FED. AID PROJECT-		
CONTRACT NO.: 91358				

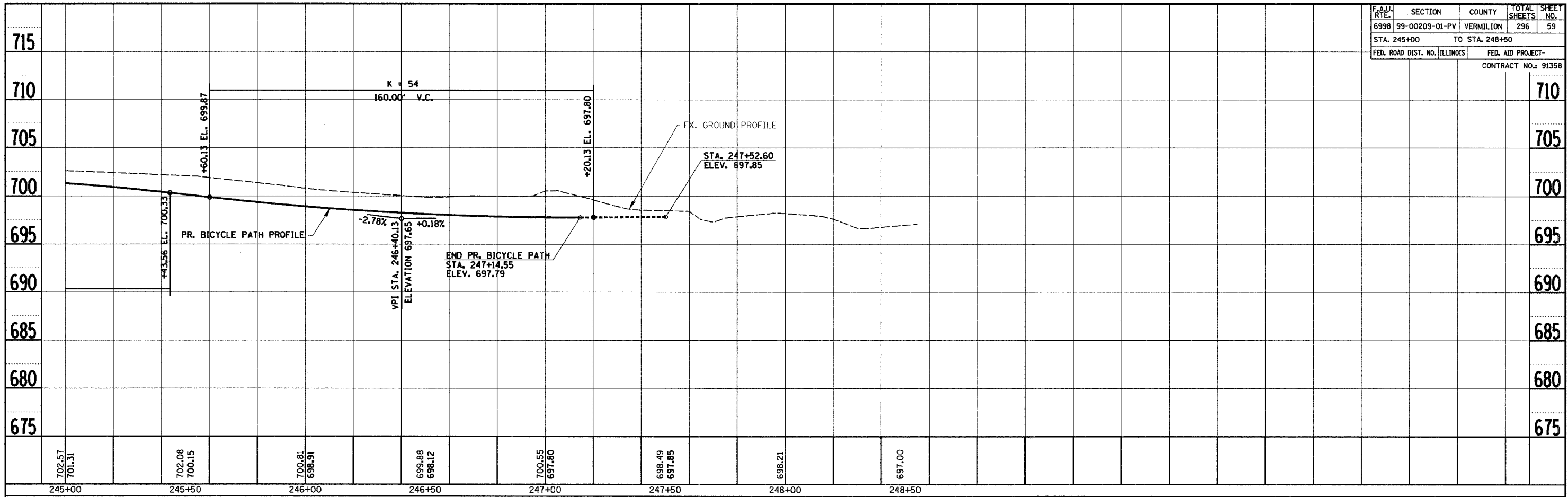

PROFILE SURVEYED BY: _____ DATE: _____
 PLOTTED BY: _____
 CHECKED BY: _____
 NOTE BOOK NO. _____
 STRUCTURE NOTATING CHRD NO. _____

PROFILE SURVEYED BY: _____ DATE: _____
 PLOTTED BY: _____
 CHECKED BY: _____
 NOTE BOOK NO. _____
 STRUCTURE NOTATING CHRD NO. _____

REVISIONS		NAME	DATE
NO.	DESCRIPTION		

CITY OF DANVILLE, ILLINOIS
 WINTER AVENUE RECONSTRUCTION
 PROPOSED PROFILE
 BICYCLE PATH
 STA. 245+00 TO STA. 248+50

SCALE: 1" = 20' HORIZ.
 1" = 5' VERT.
 DRAWN BY: NIL

DATE: 12/21/06
 CHECKED BY: MBF

F.A.J.I. RTE.	SECTION	COUNTY	TOTAL SHEETS	SHEET NO.
6998	99-00209-01-PV	VERMILION	296	60
STA. 145+00		TO STA. 151+00		
FED. ROAD DIST. NO. ILLINOIS		FED. AID PROJECT-		
CONTRACT NO.: 91358				

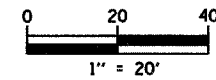
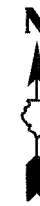

PLAN	SURVEYED	BY	DATE
	DESIGNED		
	CHECKED		
	IN CHARGE		
	NO.		

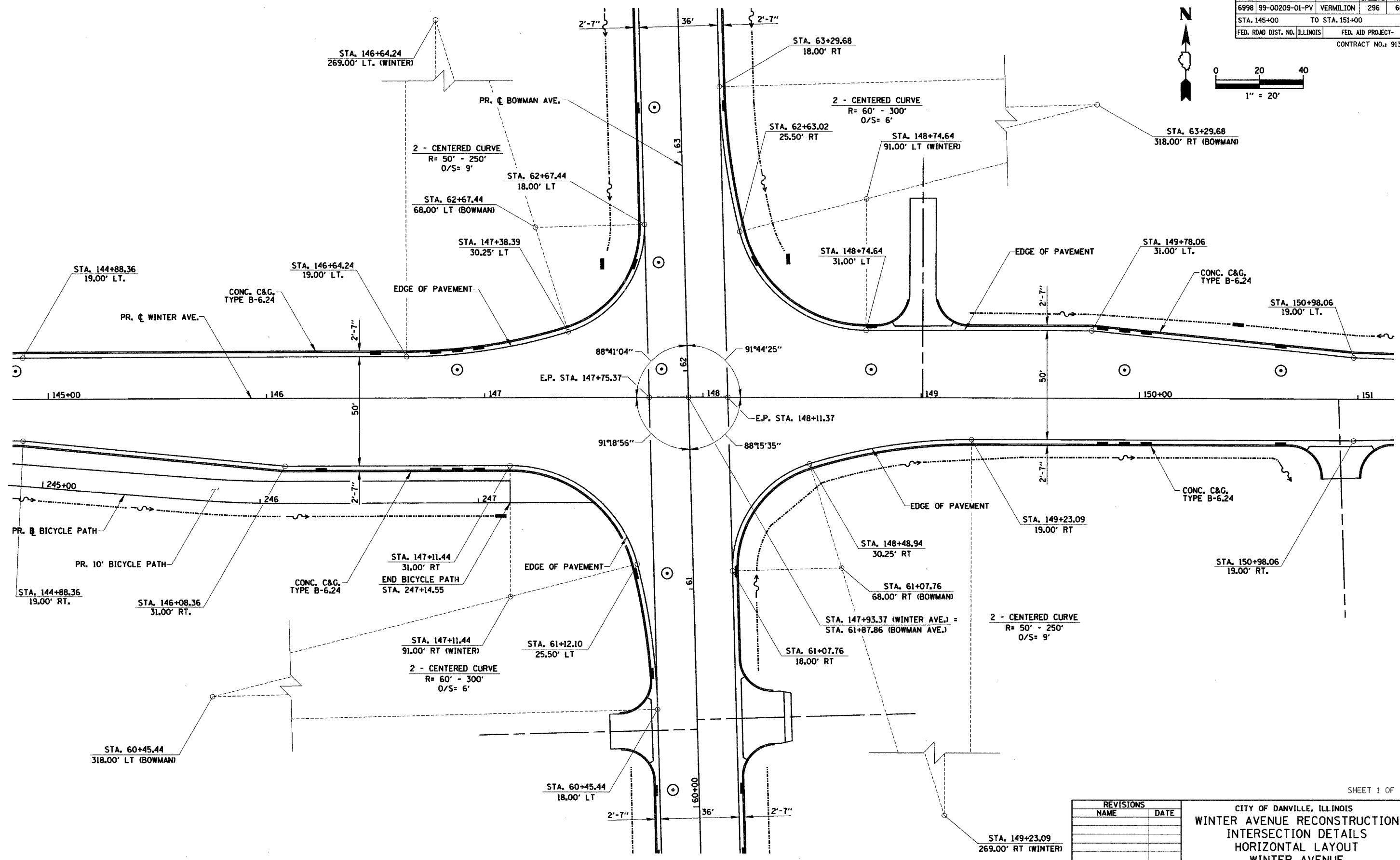

PLAN VIEW
(SHOWING HORIZONTAL CONTROL)

REVISIONS	
NAME	DATE

CITY OF DANVILLE, ILLINOIS
WINTER AVENUE RECONSTRUCTION
INTERSECTION DETAILS
HORIZONTAL LAYOUT
WINTER AVENUE
AT BOWMAN AVENUE

SCALE: 1" = 20'
DATE: 12/21/06
DRAWN BY: MLS
CHECKED BY: MBF

PLAN	SURVEYED	DATE
	NOTED	
	ALIGNED	
	CHECKED	
	BY	
	NO.	

F.A.U. RTE.	SECTION	COUNTY	TOTAL SHEETS	SHEET NO.
6998	99-00209-01-PV	VERMILION	296	61
STA. N/A	TO STA. N/A			
FED. ROAD DIST. NO.	ILLINOIS	FED. AID PROJECT-		
CONTRACT NO.: 91358				

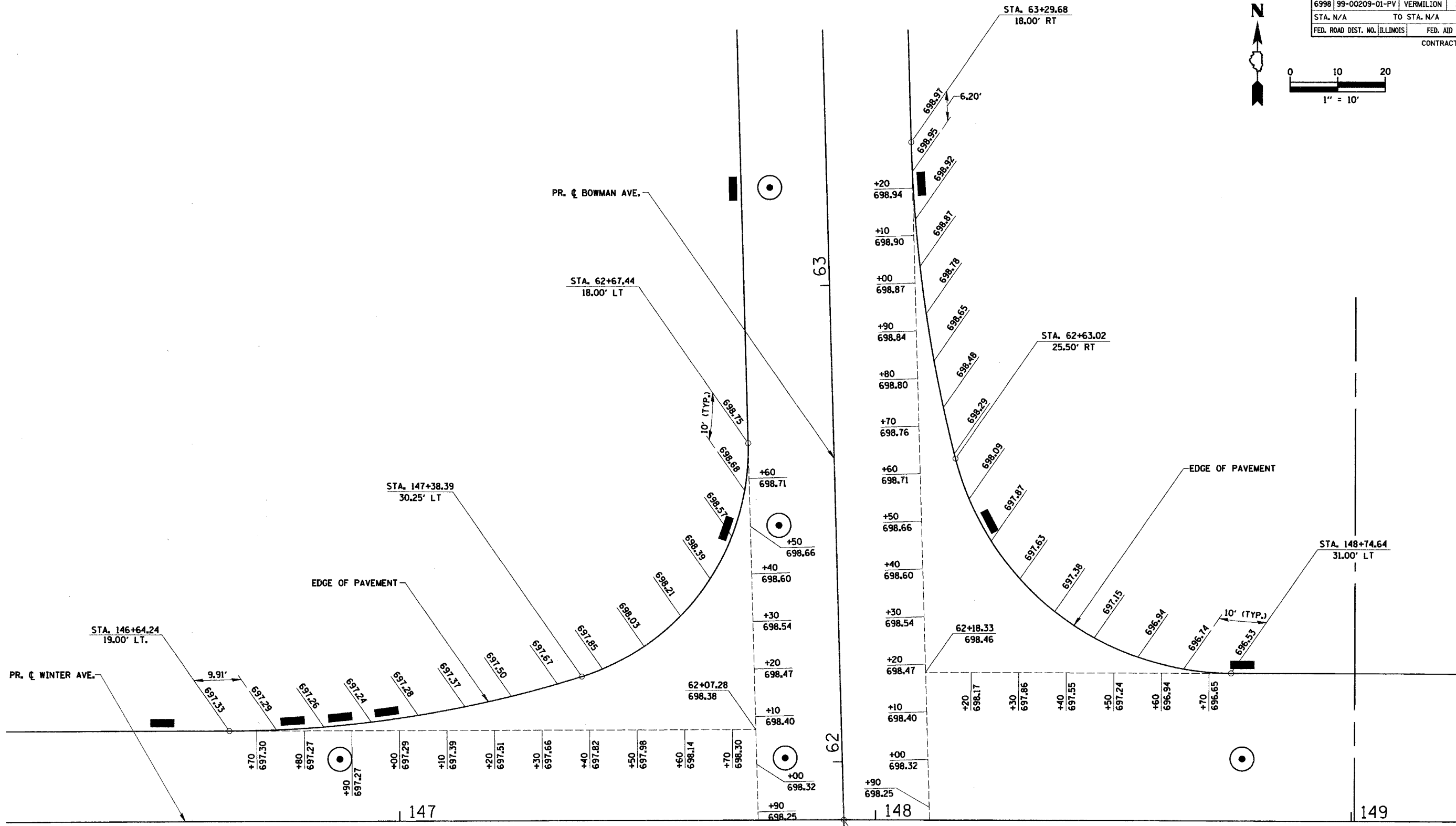
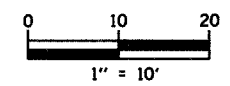

PLAN VIEW
(SHOWING VERTICAL CONTROL)

REVISIONS	
NAME	DATE

CITY OF DANVILLE, ILLINOIS
**WINTER AVENUE RECONSTRUCTION
 INTERSECTION DETAILS
 VERTICAL LAYOUT
 WINTER AVENUE
 AT BOWMAN AVENUE**

SCALE: 1" = 10'
 DATE: 12/21/06
 DRAWN BY: MLS
 CHECKED BY: MBF

F.A.I.D. RTE.	SECTION	COUNTY	TOTAL SHEETS	SHEET NO.
6998	99-00209-01-PV	VERMILION	296	62
STA. 145+00		TO STA. 151+00		
FED. ROAD DIST. NO. ILLINOIS		FED. AID PROJECT-		
CONTRACT NO.: 91358				

PLAN	SURVEYED	DATE
	ALIGNED	
	CHECKED	
	BY	
	NO. OF WAY CHECKED	
	ADD FILE NAME	

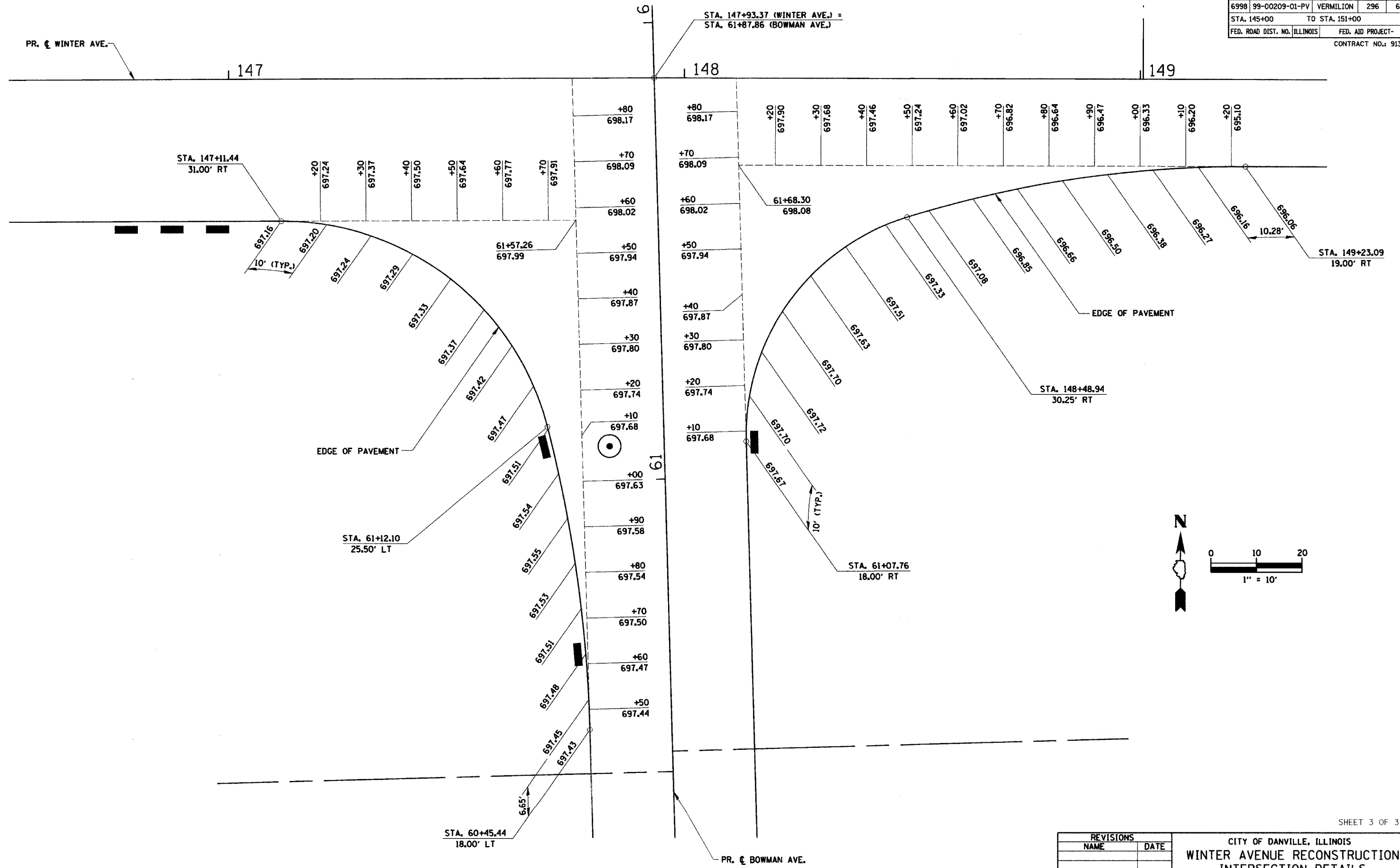

PLAN VIEW
(SHOWING VERTICAL CONTROL)

REVISIONS	
NAME	DATE

CITY OF DANVILLE, ILLINOIS
**WINTER AVENUE RECONSTRUCTION
 INTERSECTION DETAILS
 VERTICAL LAYOUT
 WINTER AVENUE
 AT BOWMAN AVENUE**

SCALE: 1" = 10'
 DATE: 12/21/06
 DRAWN BY: MLS
 CHECKED BY: MBF

PLAN	SURVEYED	DATE
NO.	BY	
	CHECKED	
	DATE	
	BY	
	CHECKED	
	DATE	

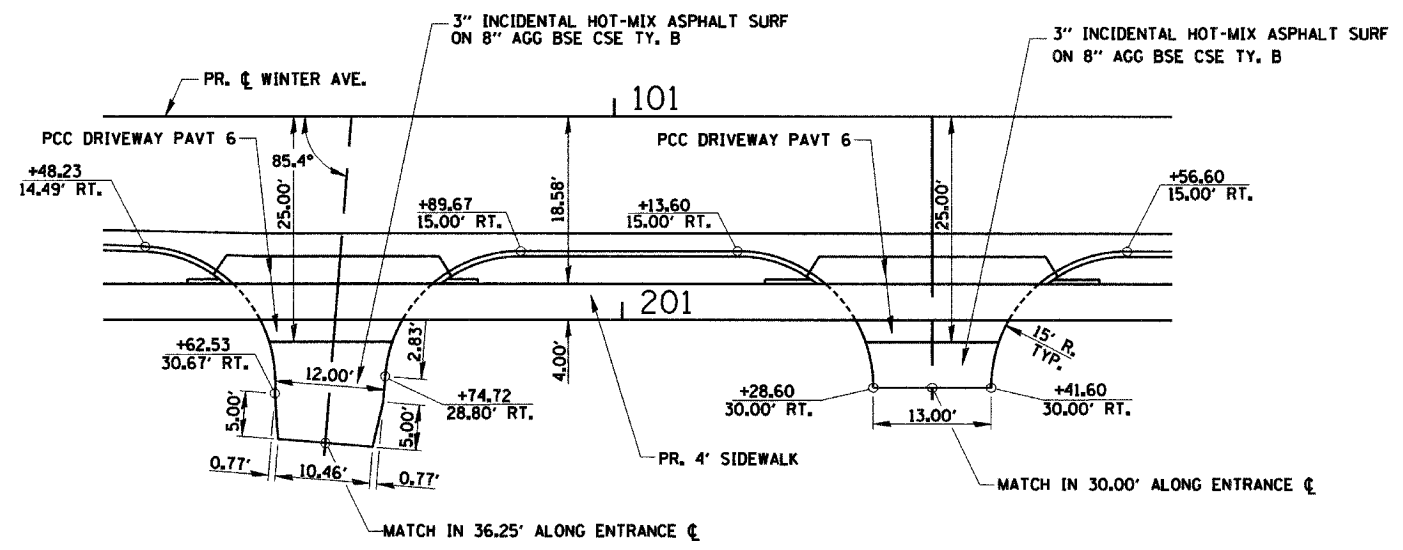

PRIVATE ENTRANCE DETAIL
(P.E.) 100+71.01

PRIVATE ENTRANCE DETAIL
(P.E.) 101+35.10

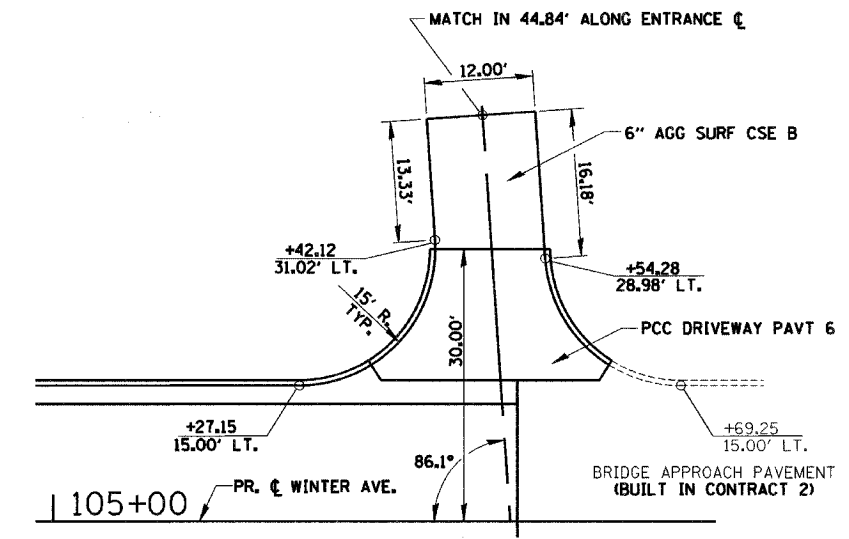

PRIVATE ENTRANCE DETAIL
(P.E.) 105+50.41

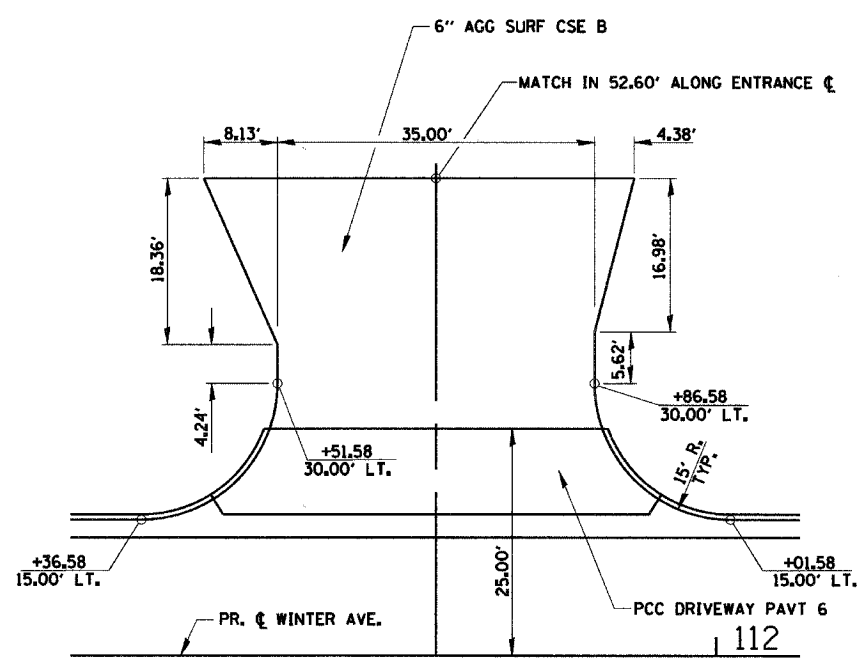

COMMERCIAL ENTRANCE DETAIL
(C.E.) 111+69.08

SEE DIST. 5 DETAIL C-1.14

SEE ENTRANCE TYPICAL SECTIONS (SHEET 5 OF 5)

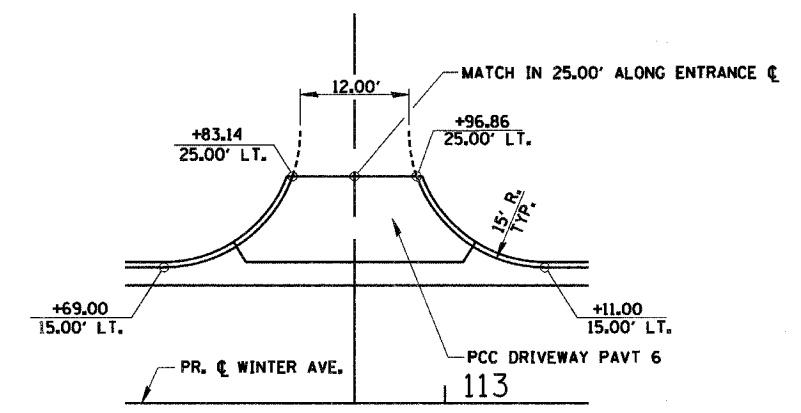

PRIVATE ENTRANCE DETAIL
(P.E.) 112+90.00

REVISIONS	
NAME	DATE

CITY OF DANVILLE, ILLINOIS
WINTER AVENUE RECONSTRUCTION
ENTRANCE DETAILS

SCALE: 1" = 10'
DRAWN BY: TDN
DATE: 12/21/06
CHECKED BY: MBF

PLAN	DATE
SURVEYED	BY
PLOTTED	
NOTED	
REVISIONS	
NO.	

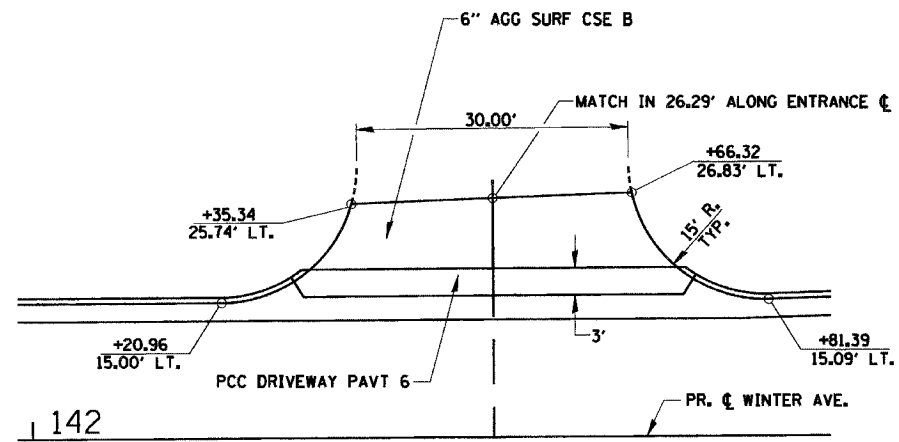

COMMERCIAL ENTRANCE DETAIL
(C.E.) 142+50.96

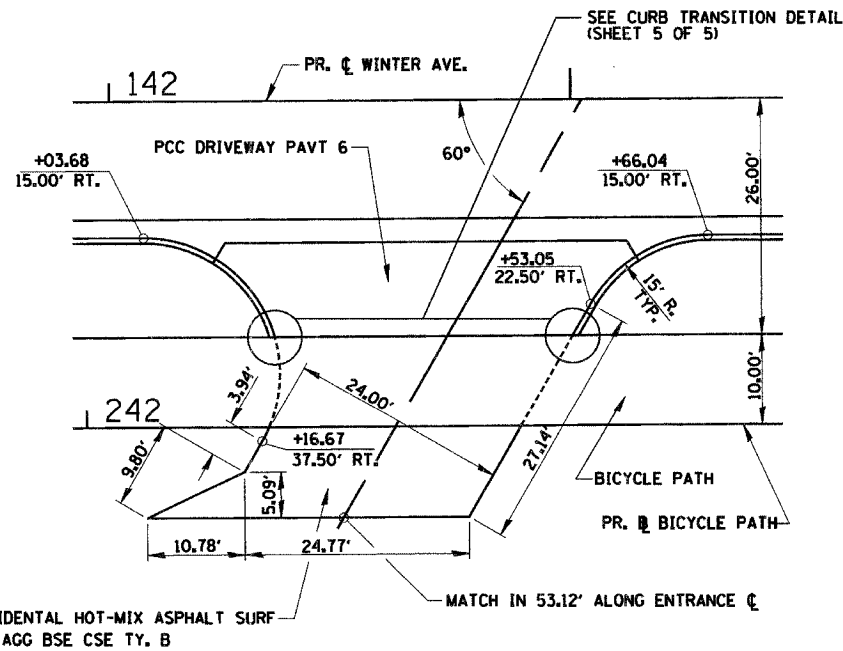

COMMERCIAL ENTRANCE DETAIL
(C.E.) 142+52.18

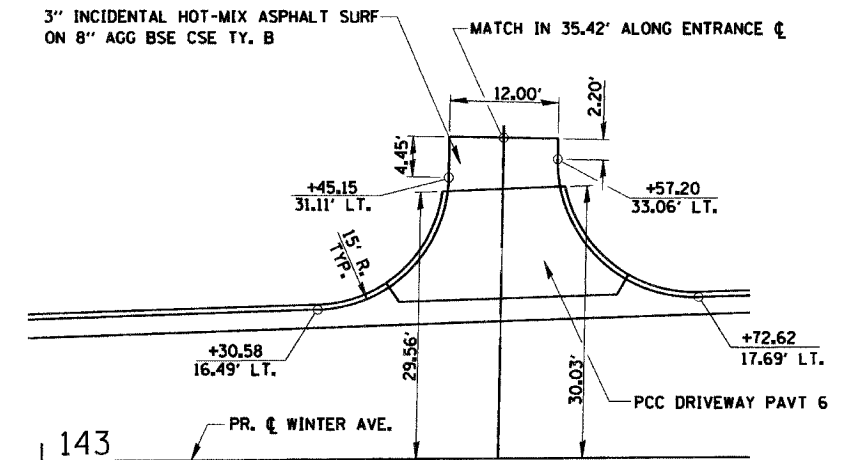

PRIVATE ENTRANCE DETAIL
(P.E.) 143+50.37

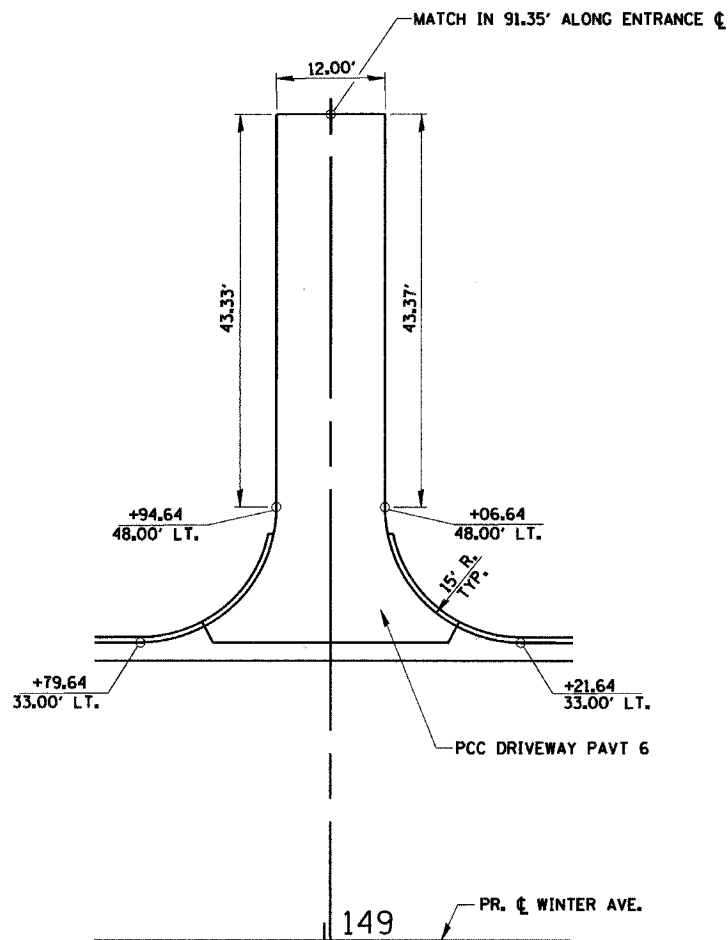

PRIVATE ENTRANCE DETAIL
(P.E.) 149+00.64

SEE DIST. 5 DETAIL C-1.14

SEE ENTRANCE TYPICAL SECTIONS (SHEET 5 OF 5)

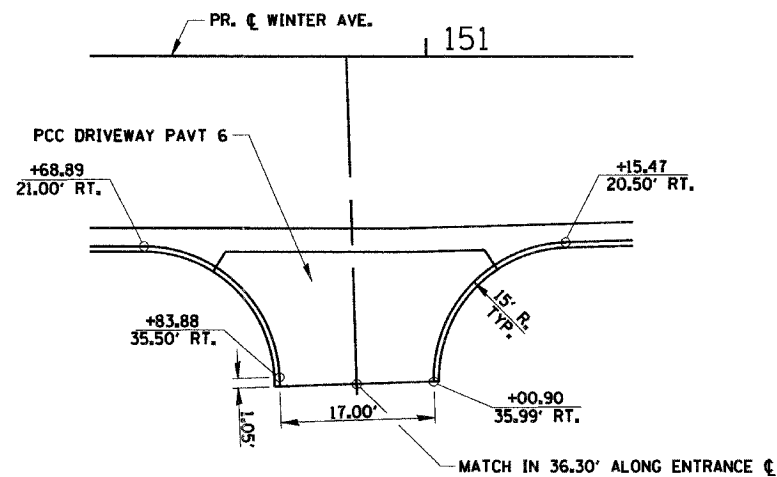

COMMERCIAL ENTRANCE DETAIL
(C.E.) 150+91.21

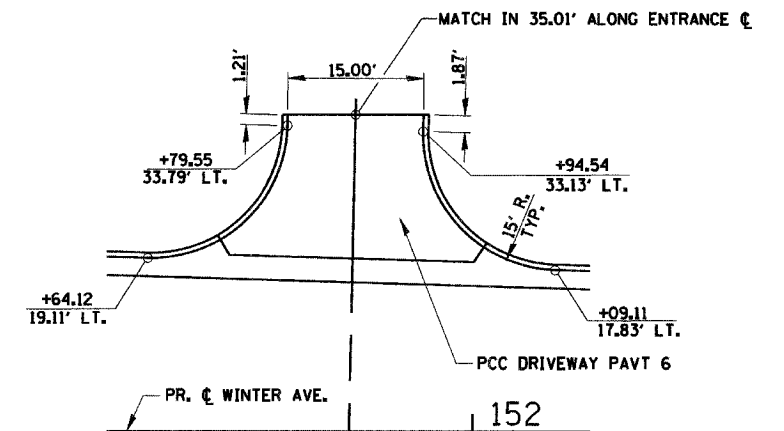

PRIVATE ENTRANCE DETAIL
(P.E.) 151+86.35

REVISIONS	
NAME	DATE

CITY OF DANVILLE, ILLINOIS
WINTER AVENUE RECONSTRUCTION
ENTRANCE DETAILS

SCALE: 1" = 10'
DRAWN BY: TDN
DATE: 12/21/06
CHECKED BY: MBF

PLAN	SURVEYED	DATE
	PLOTTED	
	CHECKED	
	BY	
	NO.	

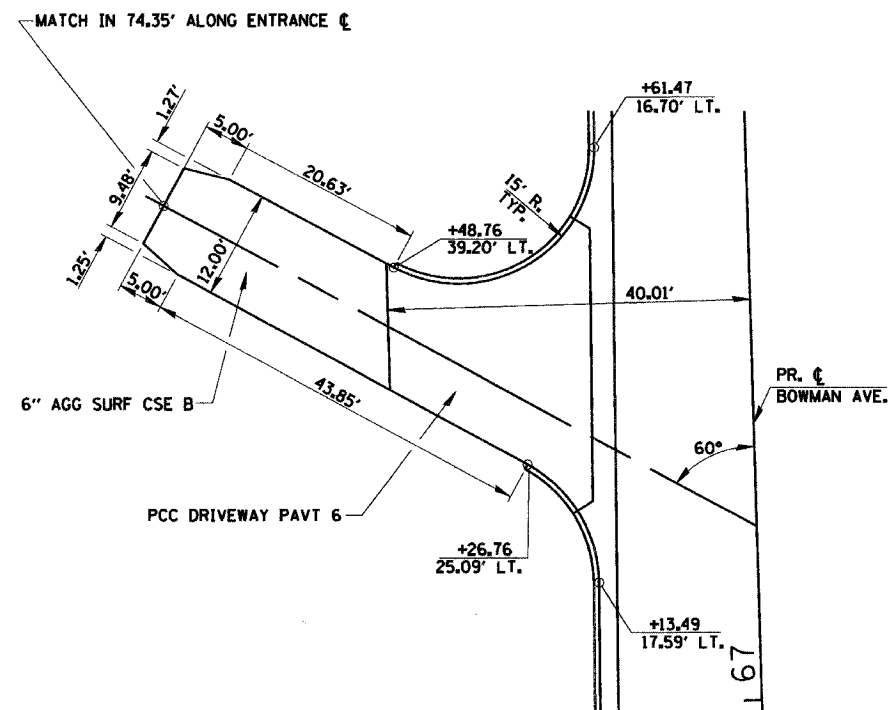

PRIVATE ENTRANCE DETAIL
(P.E.) 67+19.20

SEE DIST. 5 DETAIL C-1.14

SEE ENTRANCE TYPICAL SECTIONS (SHEET 5 OF 5)

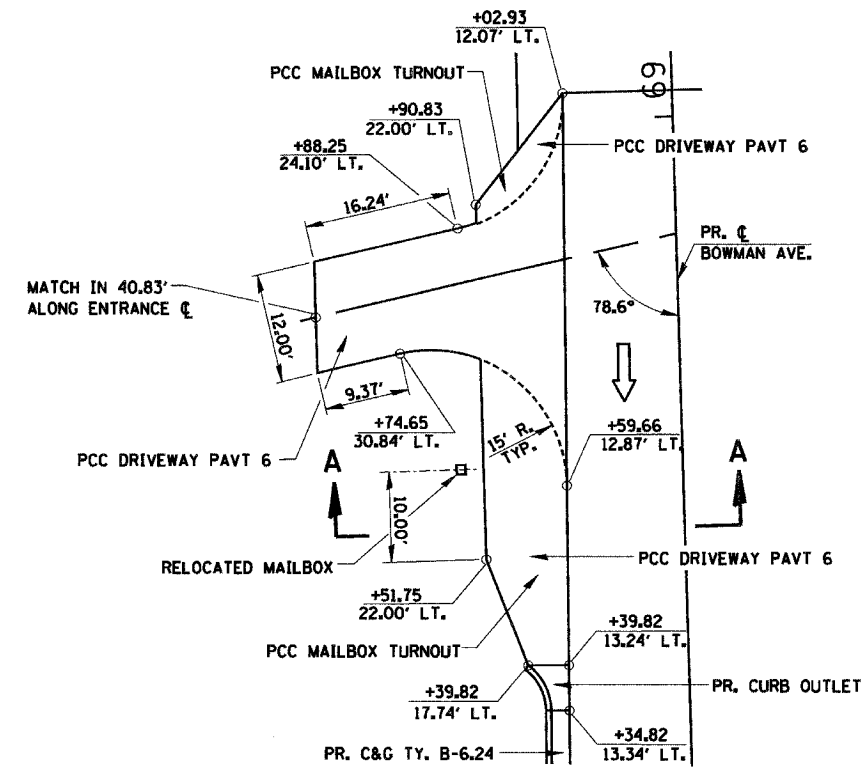

PRIVATE ENTRANCE DETAIL
(P.E.) 68+86.99

NOTES

THE TEMPORARY RELOCATION OF EXISTING MAILBOX SHALL BE IN ACCORDANCE WITH ARTICLE 107.20 OF THE STANDARD SPECIFICATIONS.

ENTRANCE SIDESLOPES SHALL BE CONSTRUCTED TO 1:4 SLOPES.

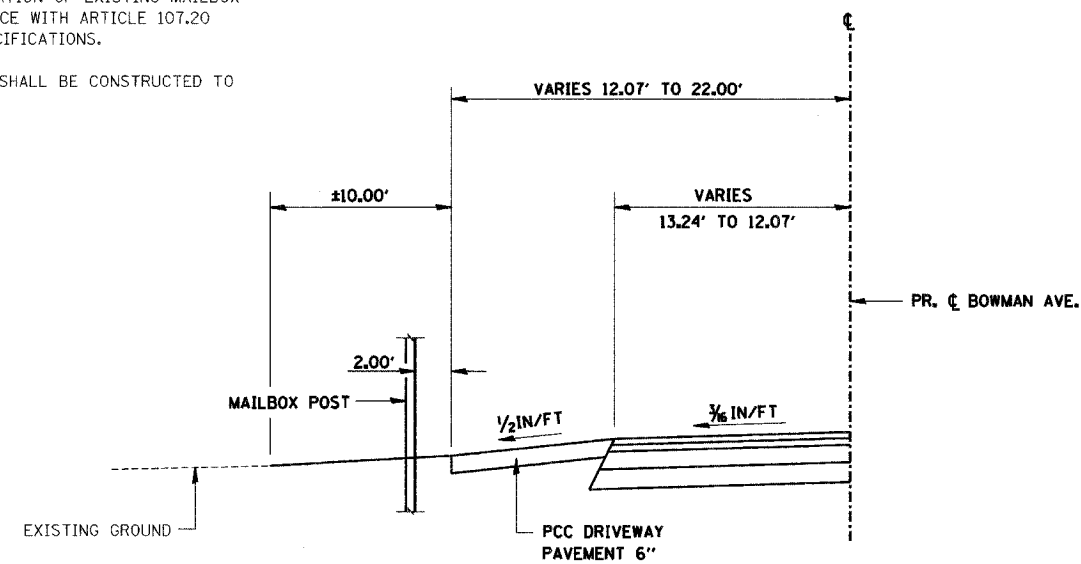

SECTION A-A

REVISIONS	
NAME	DATE

CITY OF DANVILLE, ILLINOIS
WINTER AVENUE RECONSTRUCTION
ENTRANCE DETAILS

SCALE: 1" = 10'
DRAWN BY: TDN

DATE: 12/21/06
CHECKED BY: MBF

PLAN	SURVEYED	BY	DATE
	PLOTTED		
	CHECKED		
	NO. OF WAY CHECKED		
	CAUD FILE NAME		

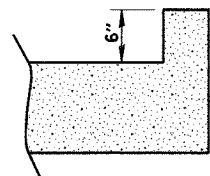
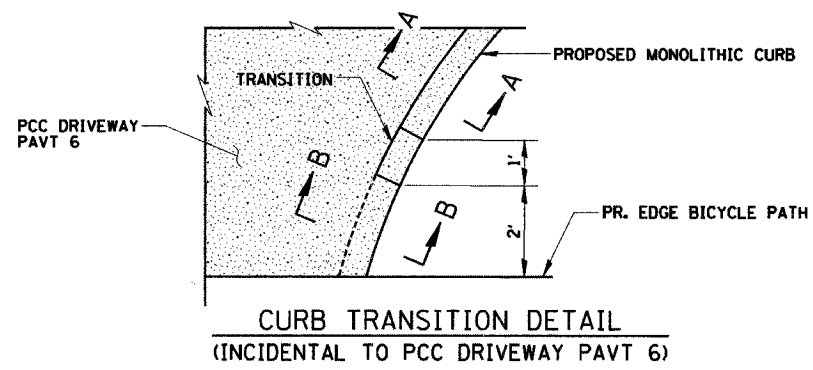

SECTION A-A

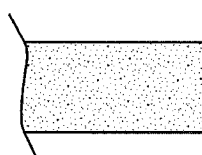

SECTION B-B

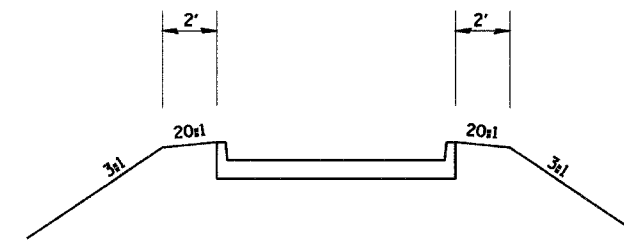

ADJACENT TO MAINLINE CURB AND GUTTER SECTION

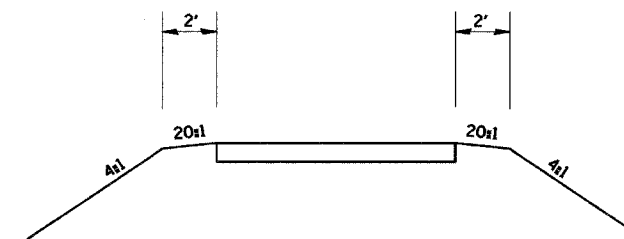

ADJACENT TO MAINLINE SHOULDER SECTION

TYPICAL ENTRANCE SECTIONS

REVISIONS	
NAME	DATE

CITY OF DANVILLE, ILLINOIS
WINTER AVENUE RECONSTRUCTION
ENTRANCE DETAILS

SCALE: NTS
DRAWN BY: TDN
DATE: 12/21/06
CHECKED BY: MBF

PLAN	DATE
SURVEYED	BY
PLOTTED	BY
CHECKED	BY
REVISIONS	BY
NO. OF WAY CHECKED	BY
CADD FILE NAME	

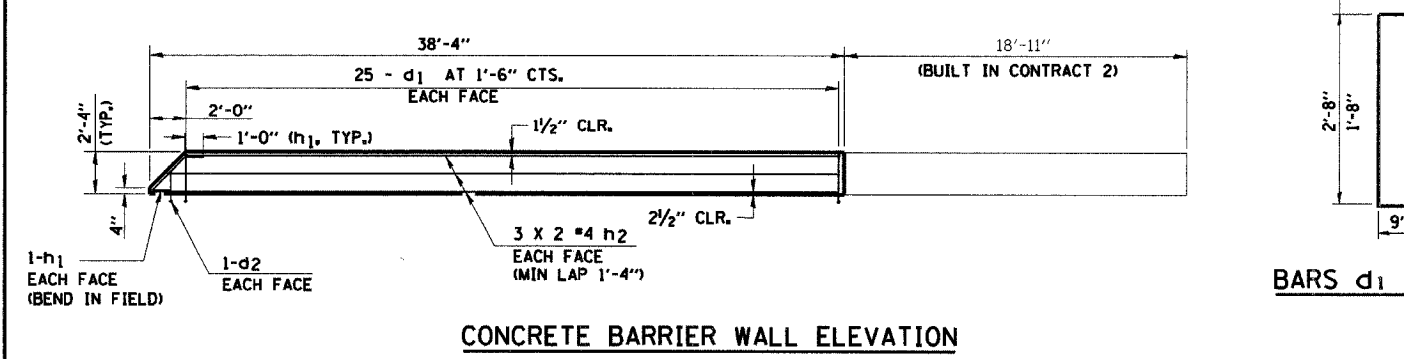
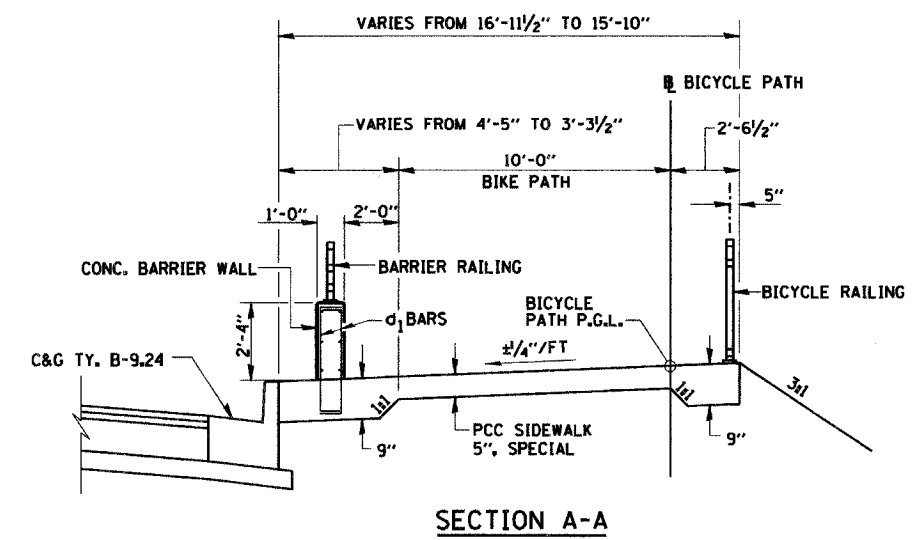
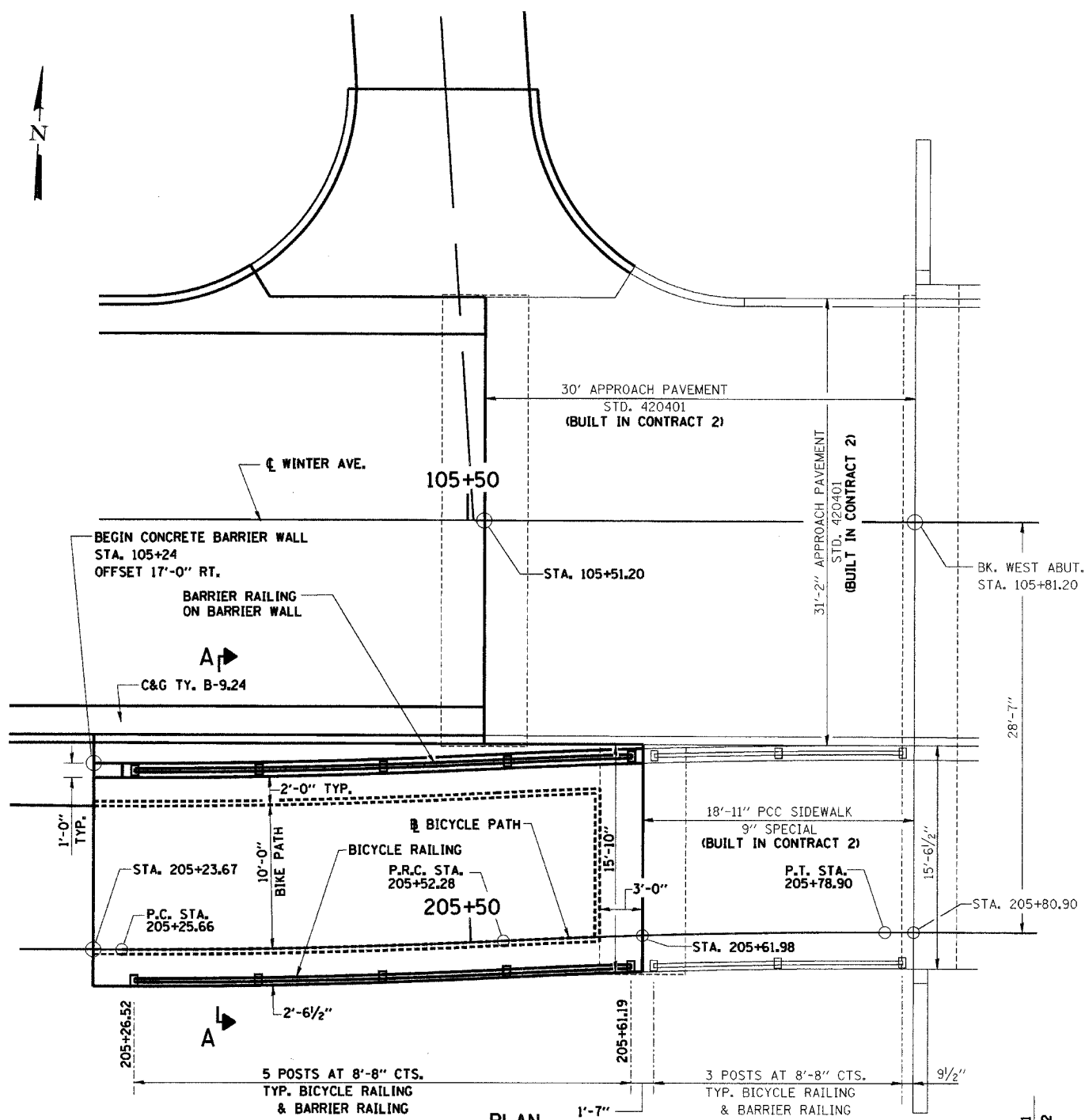

**CONCRETE BARRIER WALL
(WEST END)
BILL OF MATERIAL**

Bar	No.	Size	Length	Shape	
d ₁	50	#4	4'-2"	U	
d ₂	2	#4	3'-2"	U	
h ₁	2	#4	4'-7"	—	
h ₂	12	#4	19'-8"	—	
* Reinforcement Bars, Epoxy Coated				Pound	310
* Concrete Structures				Cu. Yds.	3.2
* Protective Coat				Sq. Yds.	24

* NOT A TOTAL QUANTITY. (FOR TOTAL QUANTITY ADD SIMILAR PAY ITEMS).

- NOTES:**
- f'c = 3500 psi
 - fy = 60,000 psi (REINF.)
 - AVOID REINFORCEMENT WHEN SPACING RAIL ANCHOR ASSEMBLY.
 - SEE "BICYCLE RAILING DETAILS" SHEET FOR RAILING DETAILS.
 - BARRIER RAILING SHALL NOT BE QUANTIFIED SEPARATELY BUT SHALL BE CONSIDERED INCLUDED IN THE INSTALLATION AND COST OF BICYCLE RAILING.
 - BARS d₁ & d₂ SHALL BE CAST IN PCC SIDEWALK 5", SPECIAL

REVISIONS		NAME	DATE
NO.	DESCRIPTION		

CITY OF DANVILLE, ILLINOIS
WINTER AVENUE RECONSTRUCTION

BICYCLE PATH DETAILS
WEST END

SCALE: N.T.S. DATE: 12/21/06
DRAWN BY: ACW CHECKED BY: MBF

PLAN	DATE	BY
SURVEYED		
DESIGNED		
CHECKED		
NO. OF MAY CHECKED		
CAD FILE NAME		

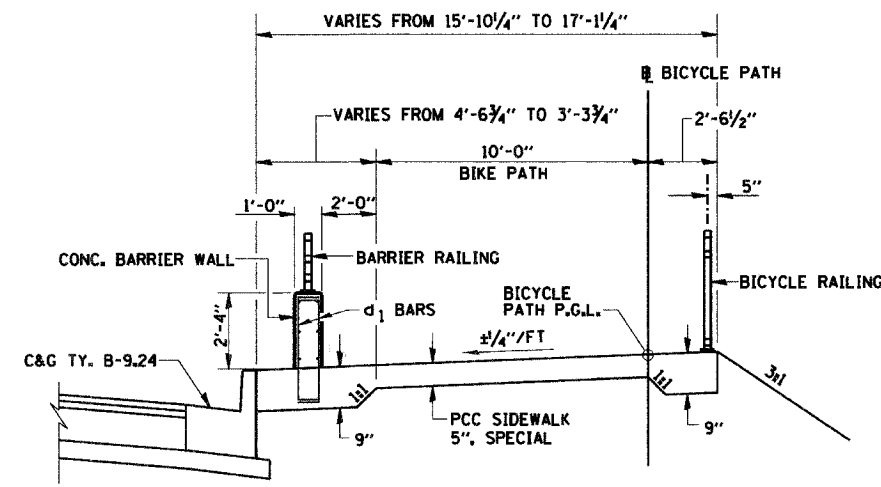
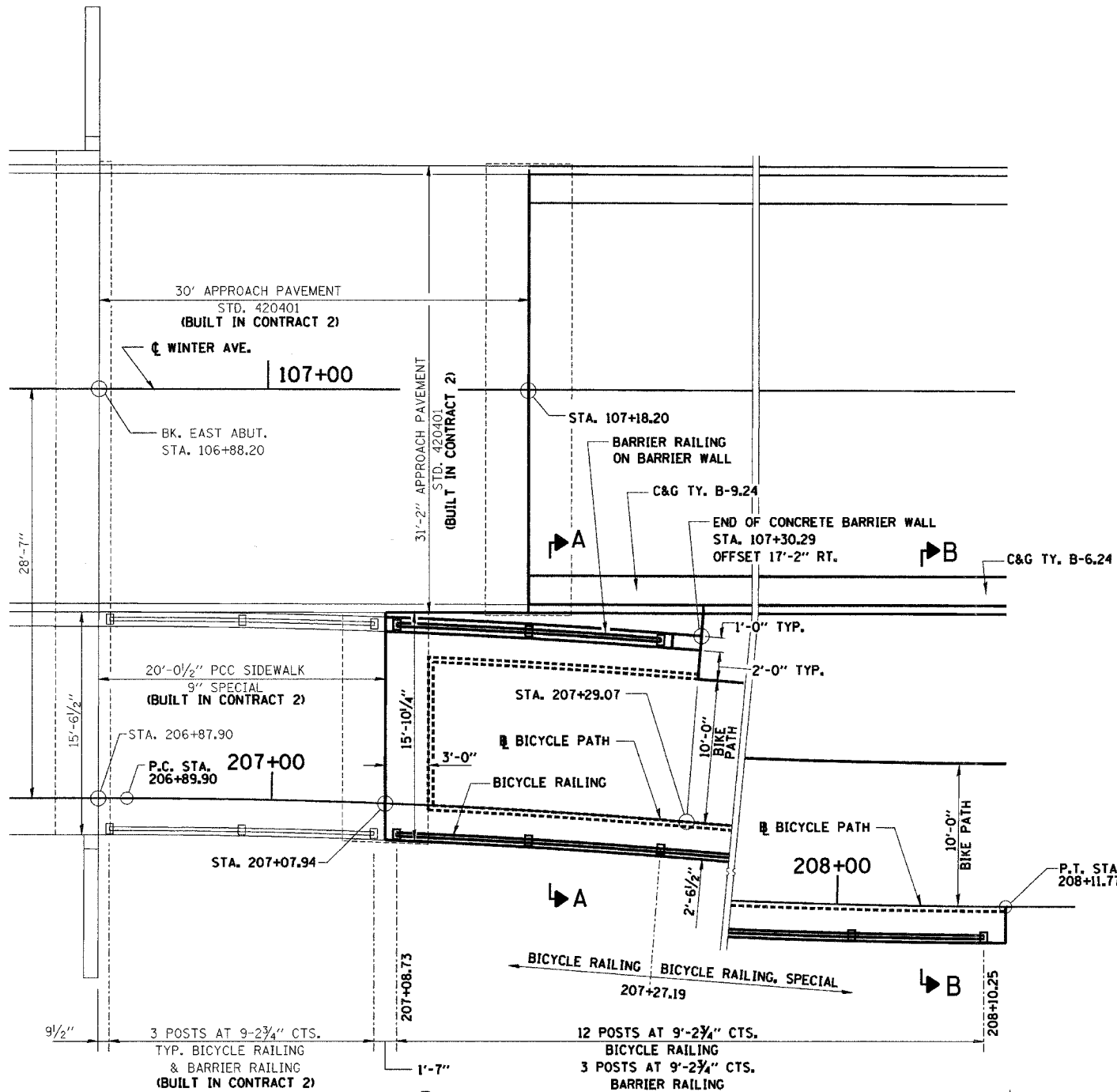

SECTION A-A

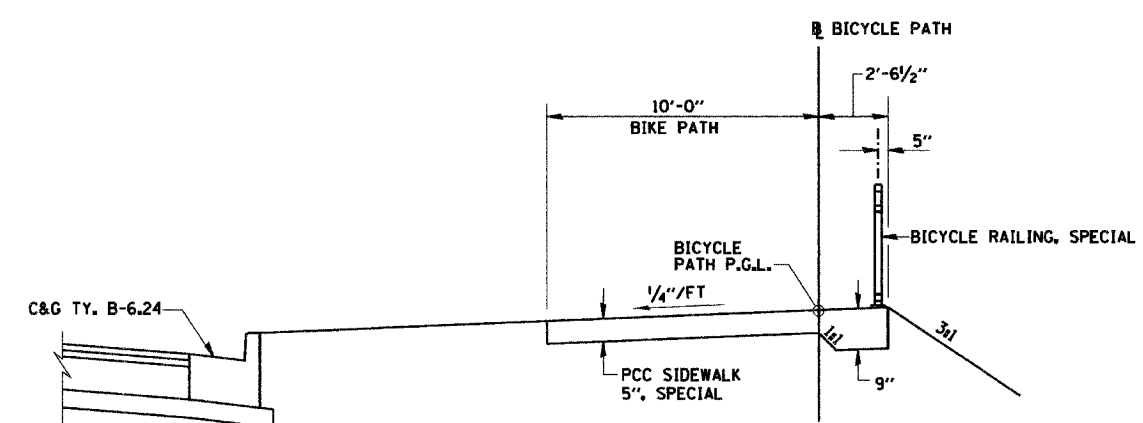

SECTION B-B

**CONCRETE BARRIER WALL
(EAST END)
BILL OF MATERIAL**

Bar	No.	Size	Length	Shape	
d ₁	28	#4	4'-2"	┌	
d ₂	2	#4	3'-2"	└	
h ₁	2	#4	4'-7"	—	
h ₃	12	#4	10'-8"	—	
* Reinforcement Bars, Epoxy Coated				Pound	170
* Concrete Structures				Cu. Yds.	1.7
* Protective Coat				Sq. Yds.	12

* NOT A TOTAL QUANTITY. (FOR TOTAL QUANTITY ADD SIMILAR PAY ITEMS).

- NOTES:
- f'c = 3500 psi
 - f_y = 60,000 psi (REINF.)
 - AVOID REINFORCEMENT WHEN SPACING RAIL ANCHOR ASSEMBLY.
 - SEE "BICYCLE RAILING DETAILS" SHEET FOR RAILING DETAILS.
 - BARRIER RAILING SHALL NOT BE QUANTIFIED SEPARATELY BUT SHALL BE CONSIDERED INCLUDED IN THE INSTALLATION AND COST OF BICYCLE RAILING.
 - BARS d₁ & d₂ SHALL BE CAST IN PCC SIDEWALK 5", SPECIAL
 - NO BARRIER RAILING IS REQUIRED ON THE OPPOSITE SIDE OF THE PATH FOR QUANTITIES COMPUTED AS BICYCLE RAILING, SPECIAL, STA. 207+27.19 TO STA. 208+10.25

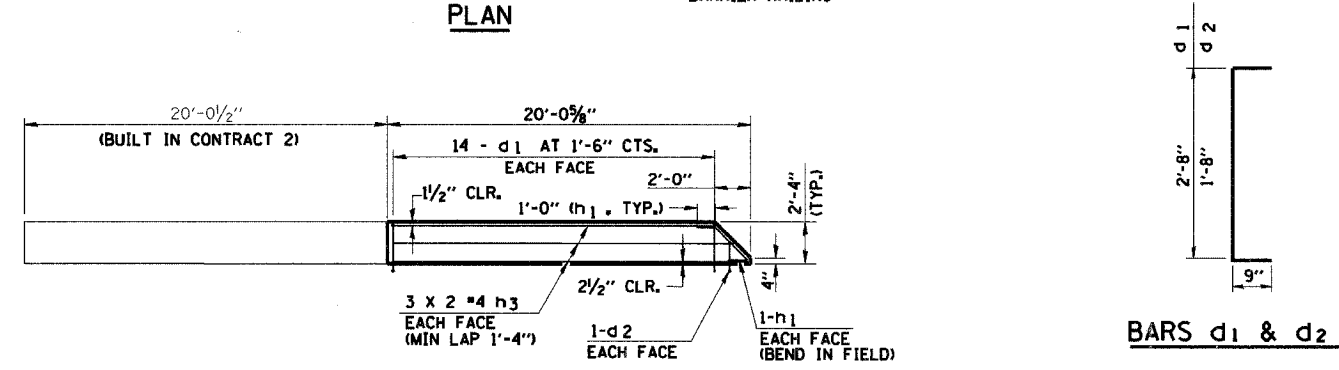

CONCRETE BARRIER WALL ELEVATION

REVISIONS	
NAME	DATE

CITY OF DANVILLE, ILLINOIS
WINTER AVENUE RECONSTRUCTION
 BICYCLE PATH DETAILS
 EAST END

SCALE: N.T.S. DATE: 12/21/06
 DRAWN BY: SRS CHECKED BY: MBF

DATE	
BY	
DESIGNED	
CHECKED	
PLANNED	
NO.	

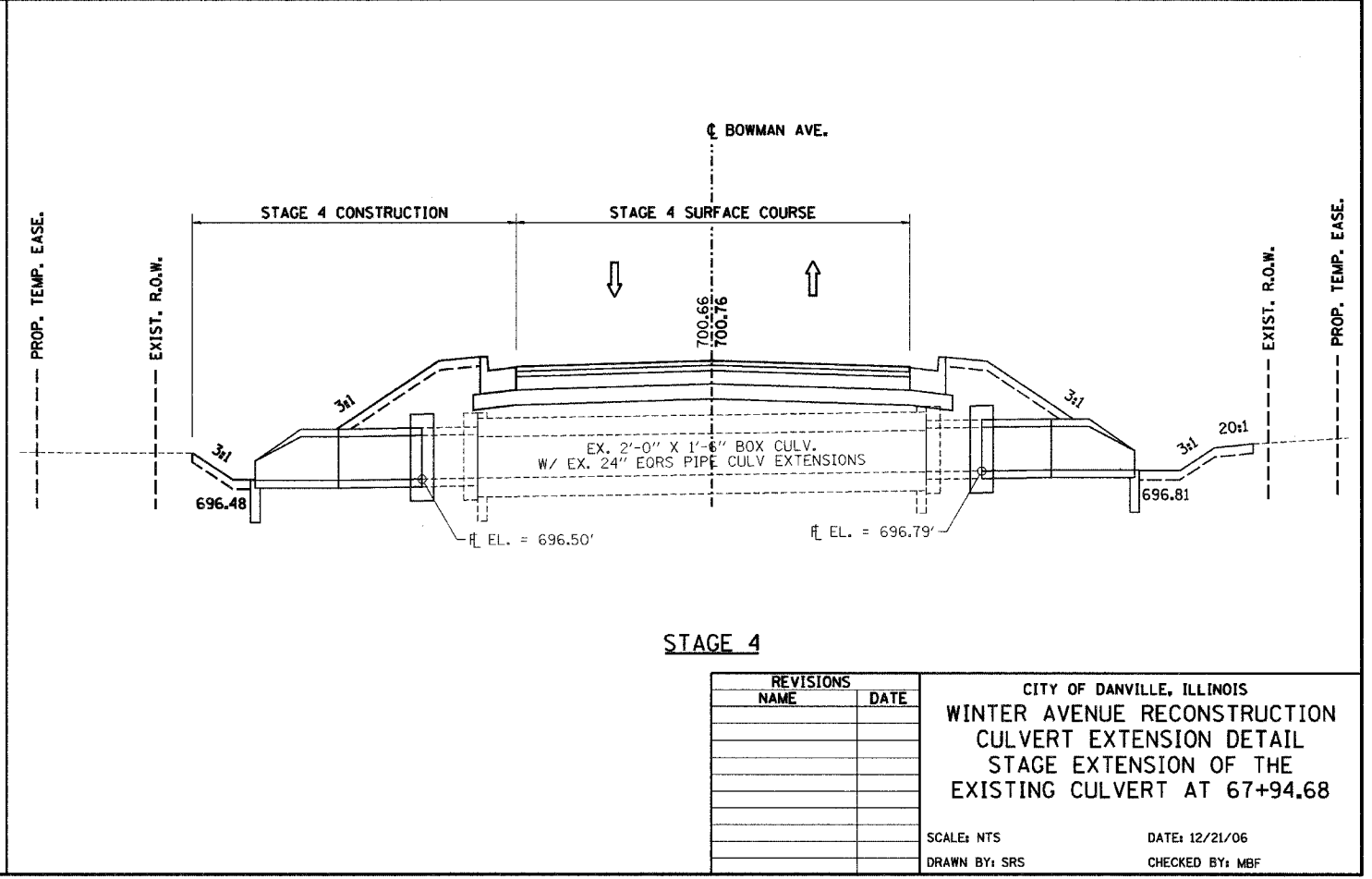
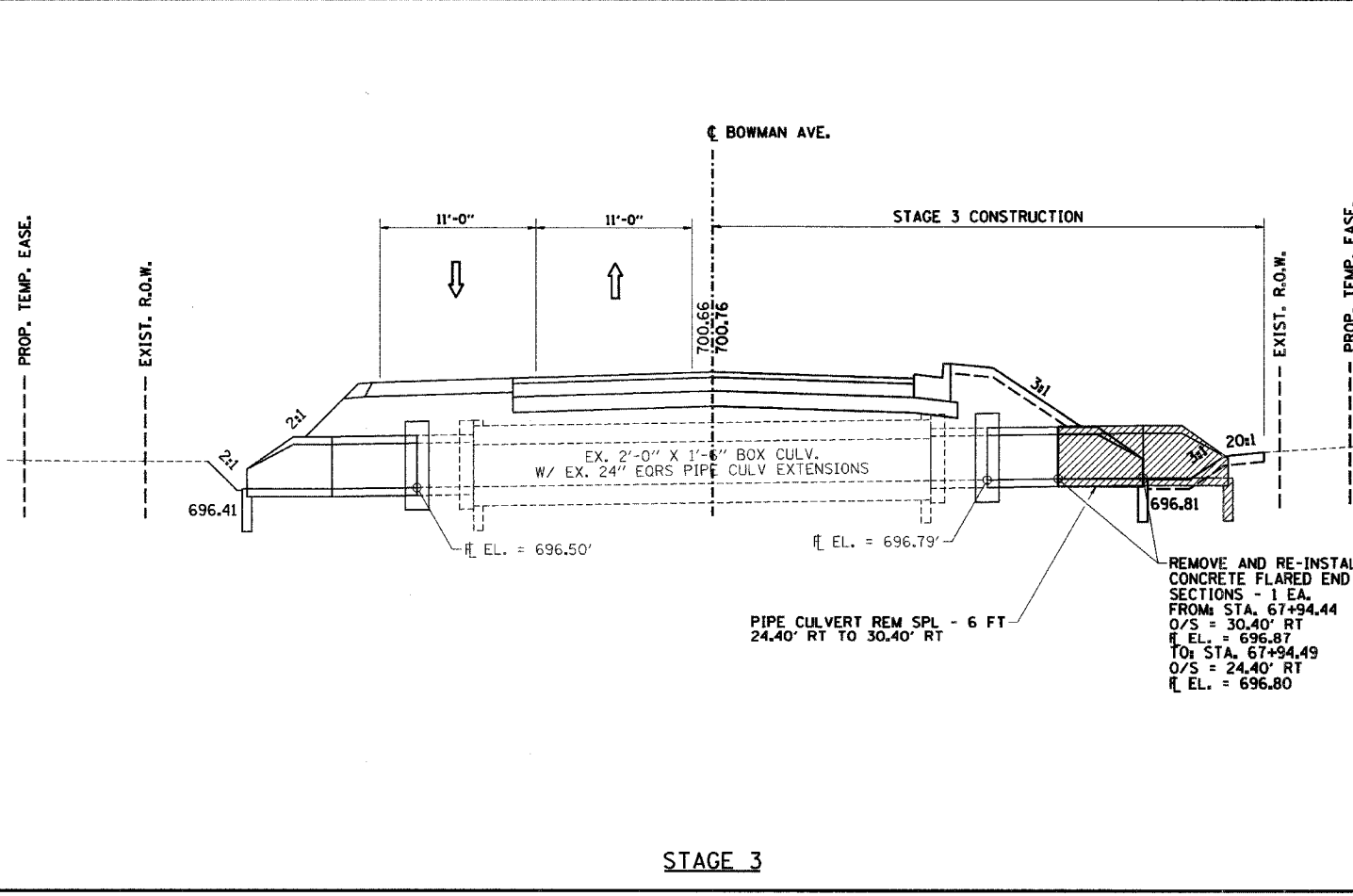
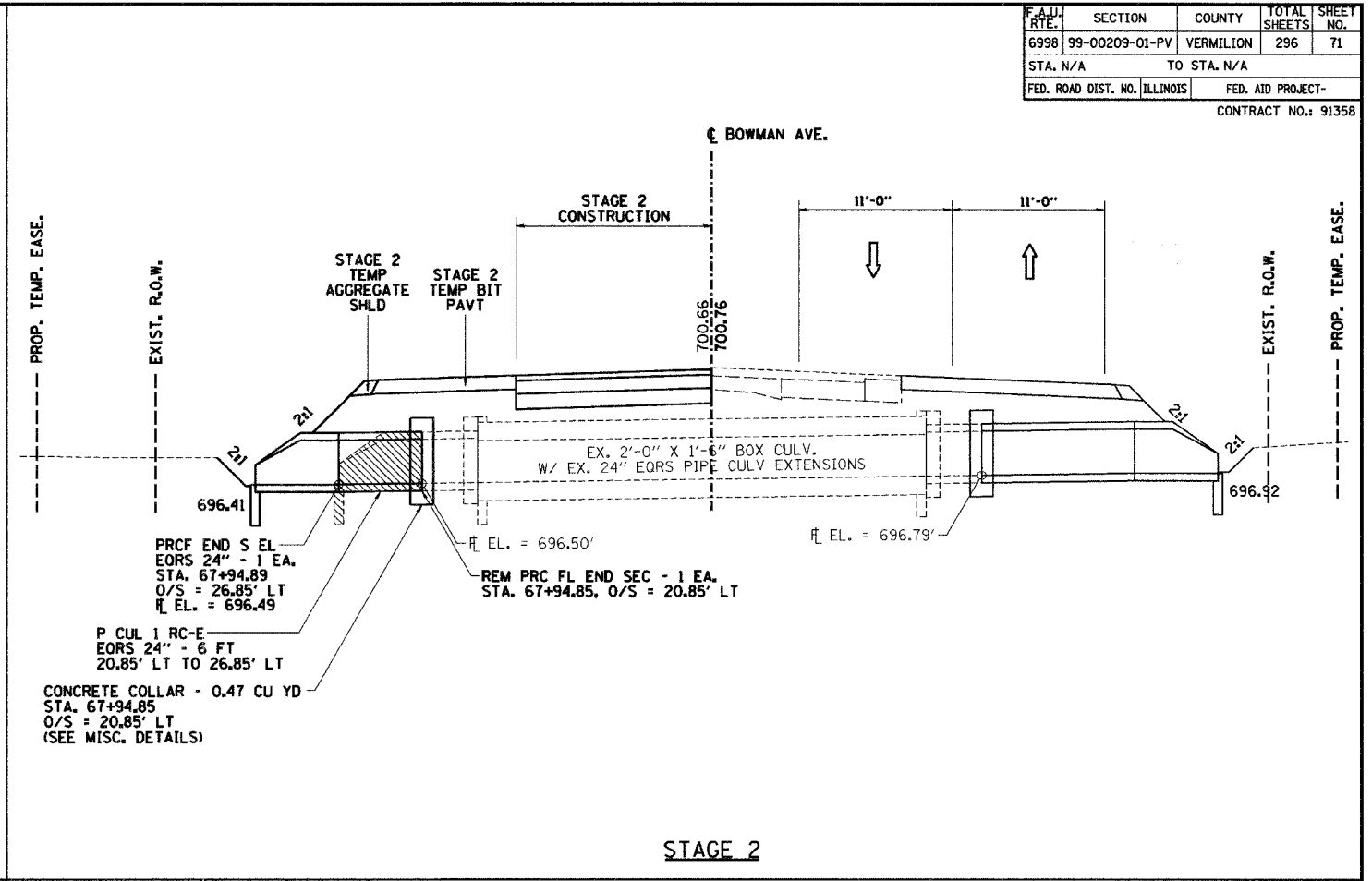
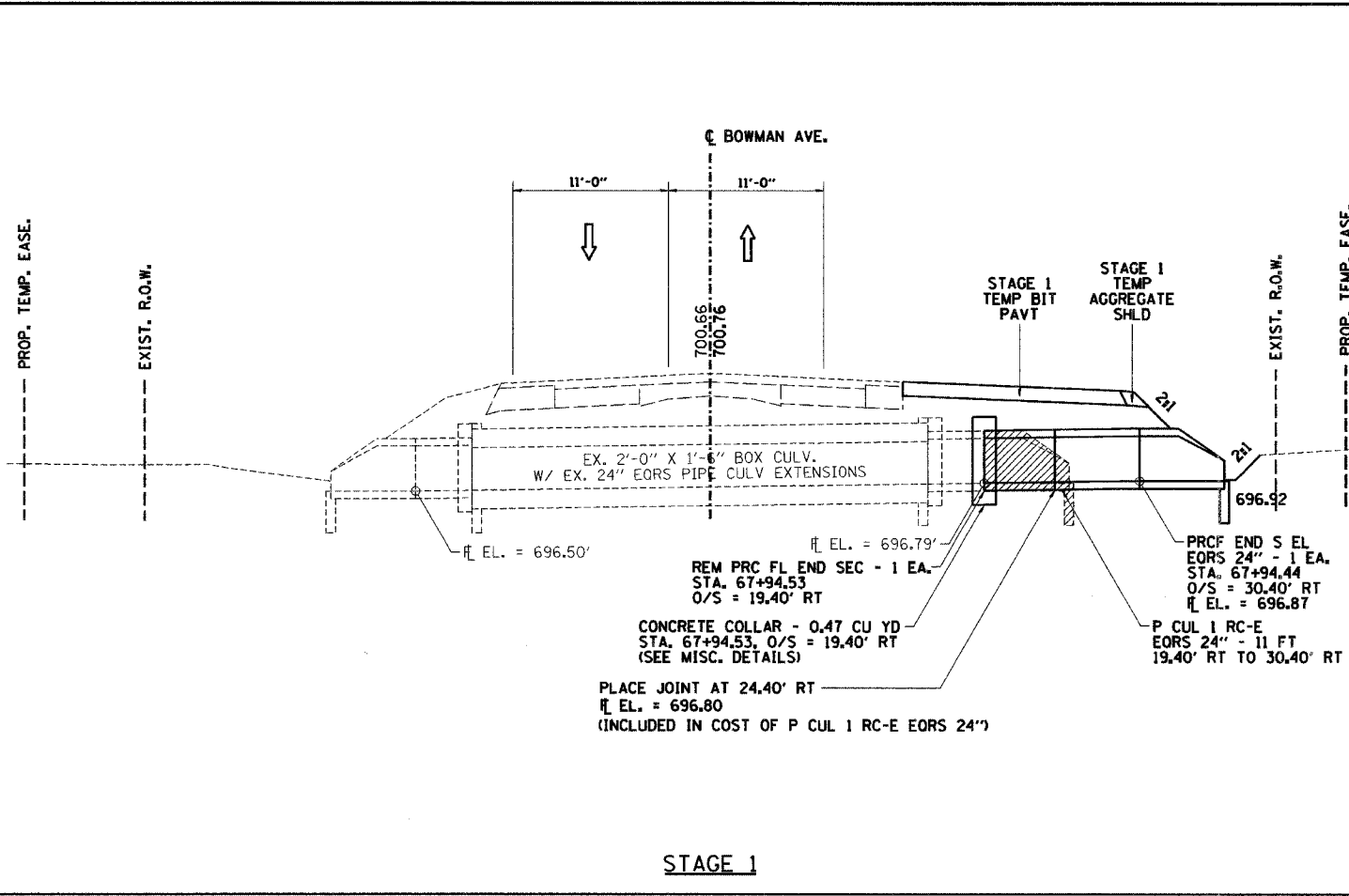

REVISIONS	
NAME	DATE

CITY OF DANVILLE, ILLINOIS
WINTER AVENUE RECONSTRUCTION
CULVERT EXTENSION DETAIL
STAGE EXTENSION OF THE
EXISTING CULVERT AT 67+94.68

SCALE: NTS DATE: 12/21/06
DRAWN BY: SRS CHECKED BY: MBF

DETAIL OF CONCRETE COLLAR FOR CULVERT EXTENSION AT STA. 67+94.68

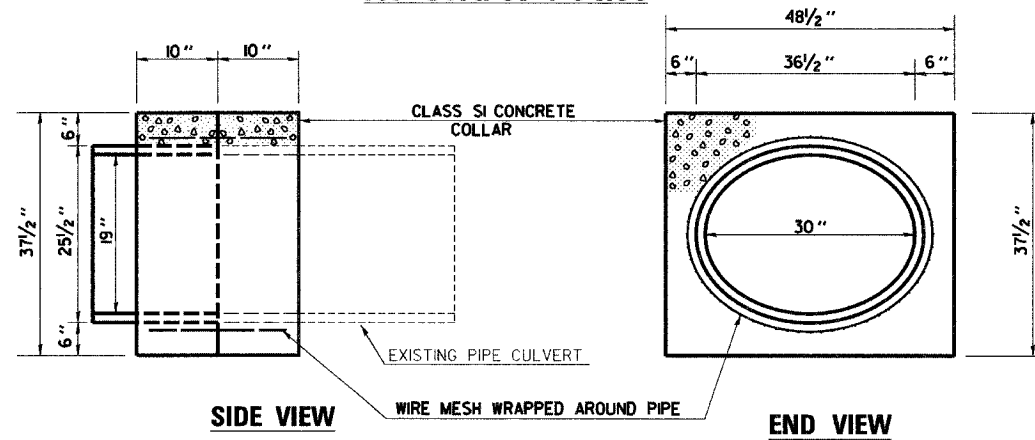

INSIDE SPAN OF PIPE (in)	INSIDE RISE OF PIPE (in)	EQUIVALENT ROUND SIZE (in)	ESTIMATED CLASS SI CONCRETE REQUIRED (20" WIDTH) (cy)
30	19	24	0.47

GENERAL NOTES

- CLASS SI CONCRETE SHALL BE USED THROUGHOUT.
- WHEN CONCRETE COLLARS ARE USED TO CONNECT PIPES OF DIFFERENT DIAMETERS, THE CONCRETE COLLAR SHOULD BE FORMED USING THE LARGEST OUTSIDE DIAMETER (SEE END VIEW).
- THE WIRE MESH SHALL WEIGH NOT LESS THAN 2.63 kg/m² (54#/100 SQ. FT.)
- CONCRETE COLLARS WILL BE PAID FOR AT THE CONTRACT UNIT PRICE, PER CUBIC METER (CUBIC YARD), FOR CONCRETE COLLARS INCLUDING ALL MATERIAL AND LABOR SPECIFIED TO COMPLETE THE WORK IN PLACE.

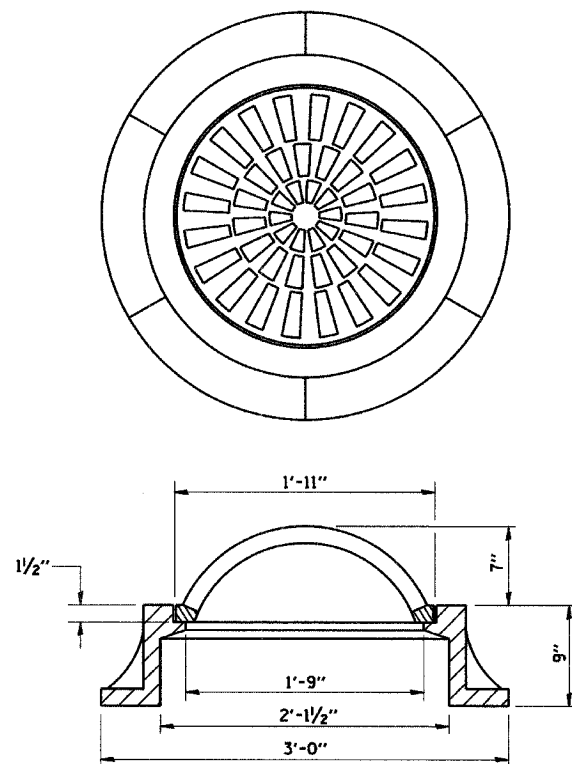

DETAIL OF SPECIAL FRAME AND GRATE
(NEENAH R-2560-E OR EQUIVALENT)

DETAIL OF STORM SEWER OUTLET PROTECTION

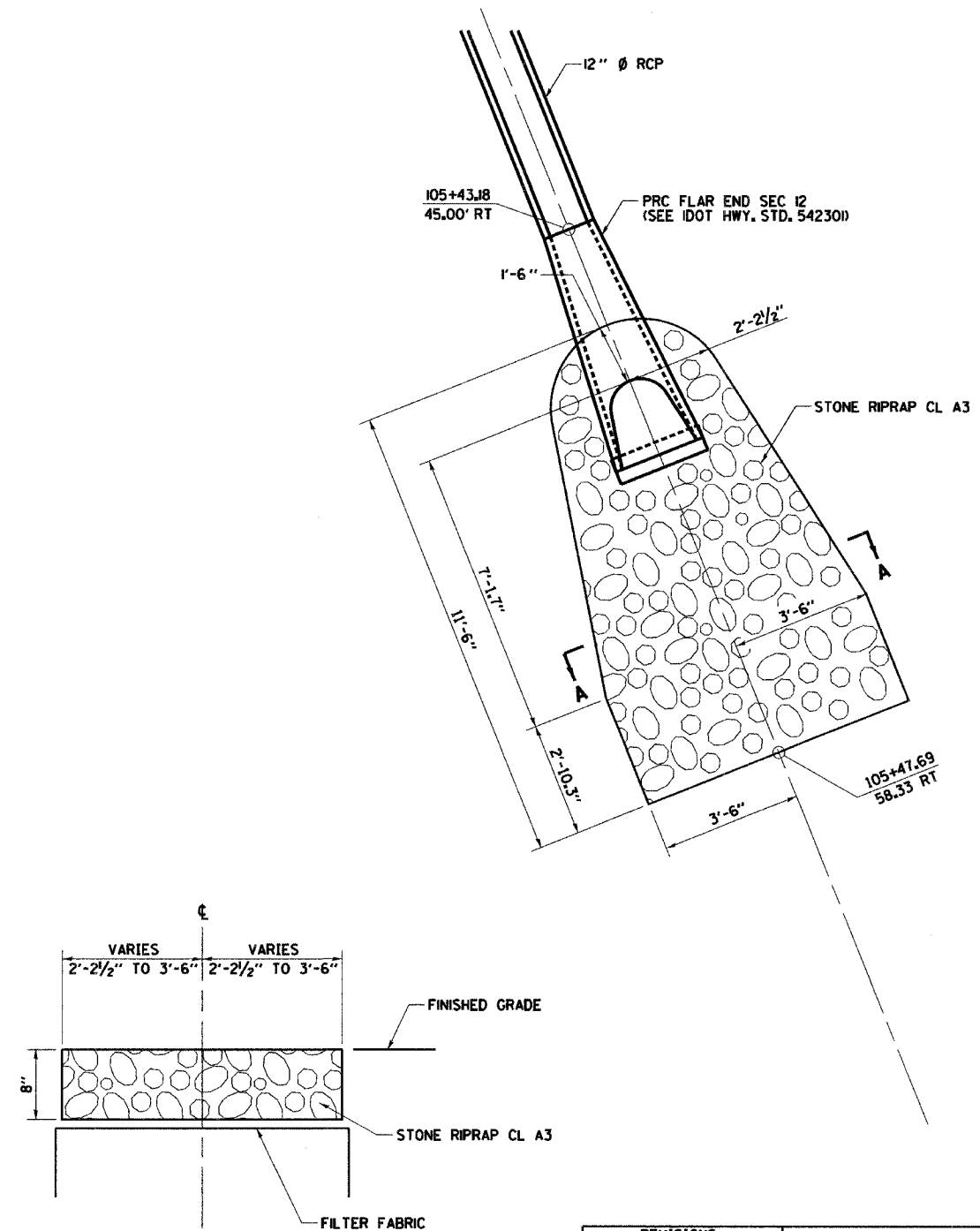

SECTION A-A
(THROUGH PAD)

REVISIONS	
NAME	DATE

CITY OF DANVILLE, ILLINOIS
WINTER AVENUE RECONSTRUCTION
MISCELLANEOUS DETAILS

SCALE: N/A
DRAWN BY: MLS
DATE: 12/21/06
CHECKED BY: MBF

PLAN NO. _____
DATE _____
BY _____
SURVEYED _____
DRAWN _____
CHECKED _____
REVISIONS _____
CADD FILE NAME _____

DATE	
BY	
PLANNED	
CHECKED	
DATE	
NO.	

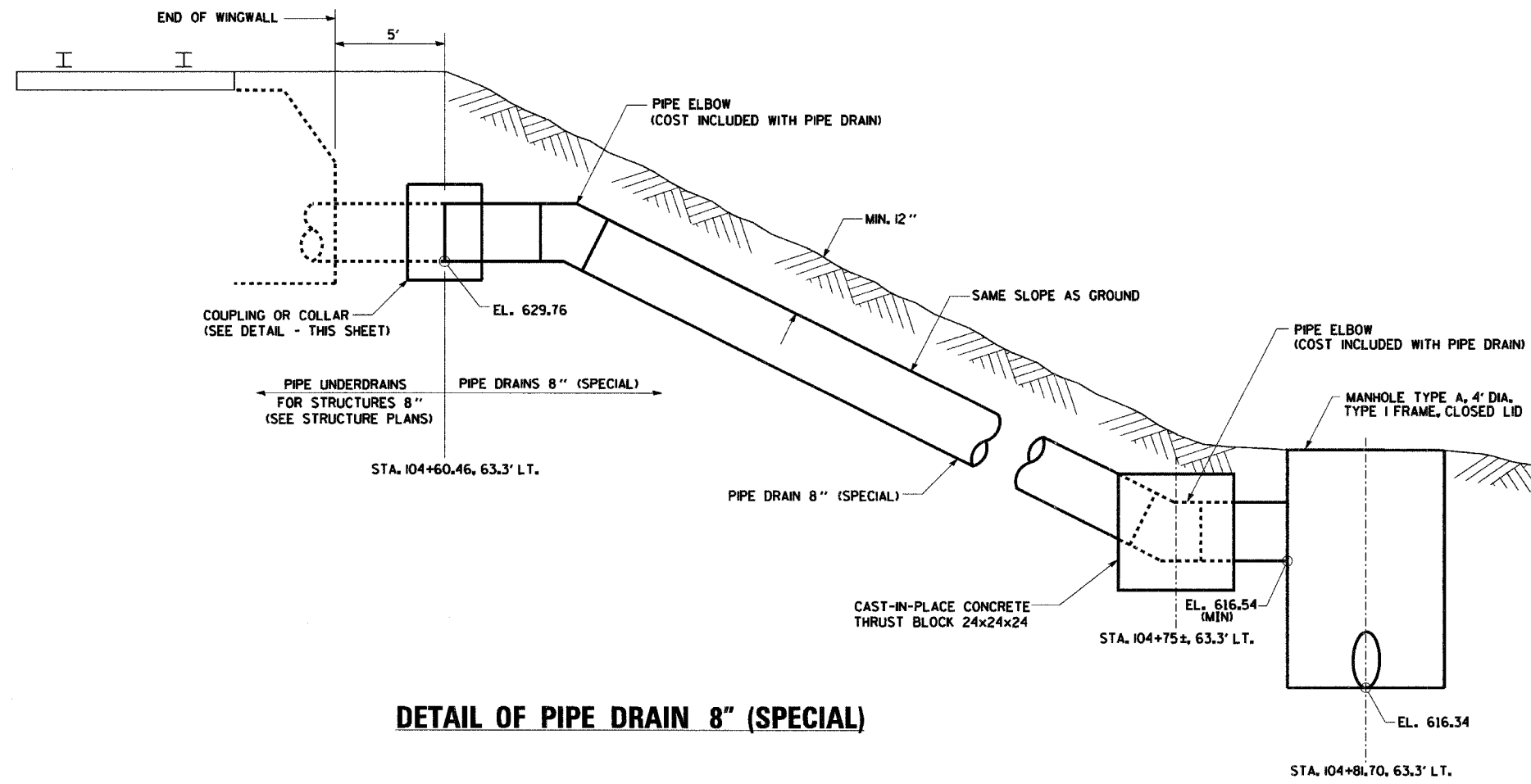

DETAIL OF PIPE DRAIN 8" (SPECIAL)

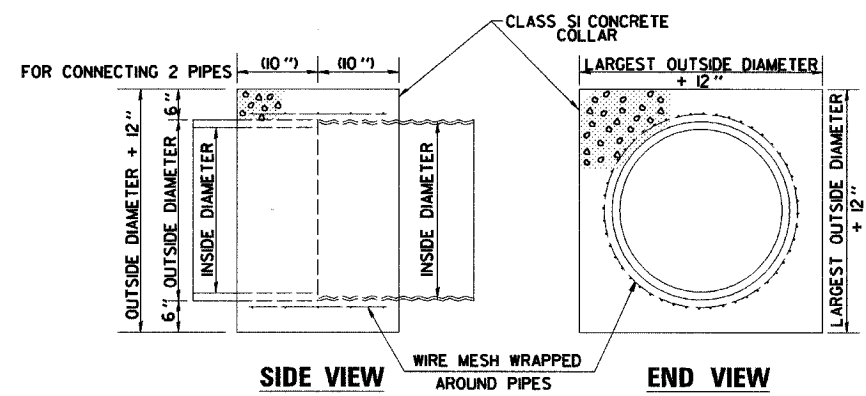

DETAIL OF CONCRETE COLLAR

INSIDE DIAMETER OF PIPE	ESTIMATED CLASS SI CONCRETE REQUIRED
(in)	(yd ³)
8	0.16

GENERAL NOTES

1. CLASS SI CONCRETE SHALL BE USED THROUGHOUT.
2. THE WIRE MESH SHALL WEIGH NOT LESS THAN 54#/100 SQ. FT.
3. CONCRETE COLLAR, IF NECESSARY, WILL NOT BE PAID FOR SEPARATELY BUT INCLUDED IN THE COST OF PIPE DRAIN 8" (SPECIAL).

REVISIONS	
NAME	DATE

CITY OF DANVILLE, ILLINOIS
WINTER AVENUE RECONSTRUCTION
 MISCELLANEOUS DETAILS

SCALE: N/A
 DATE: 12/21/06
 DRAWN BY: SRS
 CHECKED BY: MBF

PLAN SURVEYED BY DATE
 FLOTTED BY
 CHECKED BY
 RT. OF WAY CHECKED BY
 CAD FILE NAME

STR. NO.	A3	A2	A1	B11	B6	B8A	B8	B5	B7	B2	B3	B9	B4	B1	B10	C47	C2A	C46	C1	C2	C49	C48	
STATION	101+00.00	101+00.00	101+00.00	104+25.00	104+50.00	104+81.70	104+81.70	104+81.70	104+91.70	104+91.70	104+91.70	105+01.70	105+01.70	105+30.00	105+43.18	107+23.70	107+23.70	107+23.70	107+27.11	107+69.31	107+69.31	107+69.31	
OFFSET (ft)	0.00	14.70 LT	14.70 RT	14.70 RT	15.20 RT	63.30 LT	15.20 LT	15.20 RT	15.20 LT	6.00 RT	15.20 RT	14.70 LT	14.70 RT	6.00 RT	45.00 RT	14.70 LT	6.00 LT	14.70 RT	35.81 RT	6.00 LT	14.70 LT	14.70 RT	
TYPE	MH-A	INL-A	INL-A	INL-A	INL-B	MH-A	INL-B	INL-B	INL-B	MH-A	INL-B	INL-A	INL-A	MH-A	RCFES	INL-A	MH-A	INL-A	MH-A	MH-A	MH-A	INL-A	INL-A
DIA. (ft)	4.00	2.00	2.00	2.00	3.00	4.00	3.00	3.00	3.00	4.00	3.00	2.00	2.00	4.00	1.00	2.00	4.00	2.00	5.00	5.00	2.00	2.00	
F&G	T1-CL	T3	T3	T3	T3	T1-CL	T3	T3	T3	T1-CL	T3	T3	T3	T1-CL		T3	T1-CL	T3	T1-CL	T3	T3	T3	
RIM EL.	612.18	611.85	611.85	616.97	616.85	621.70	616.72	616.72	616.71	616.95	616.71	616.72	616.72	617.08		621.64	621.88	621.64	622.91	624.01	623.77	623.77	
INV. N	608.59		609.11				614.09			613.87	613.95				613.60	618.92	618.74	618.92	618.10	617.74	618.29	619.49	
INV. S	608.59	609.11				616.34			613.95	613.88							618.74		618.10	617.74	618.29	619.49	
INV. E	608.52			614.27	614.14		614.01	614.00	613.97	613.85	613.98						618.68		613.44	617.74	618.29	619.49	
INV. W	608.48				614.16	616.54		614.02	613.97		613.98	614.01	614.01	613.71					610.97	617.74 /613.97			

PIPE NO.	A2	A1	B11	B6	B8B	B8A	B8	B5	B7	B3	B9	B4	B2	B1	C47	C2A	C46	C49	C48
SIZE (in)	12	12	12	12	8	12	12	12	12	12	12	12	12	12	12	12	12	12	12
LENGTH (ft)	12.00	12.00	23.00	29.00	22.00	45.00	8.00	7.00	18.00	6.00	8.00	8.00	34.00	39.00	6.00	42.00	18.00	6.00	18.00
TYPE/CLASS	1 / A	1 / IV	1 / IV	1 / IV	PIPE DRAIN (SPECIAL)	1 / IV	1 / IV	1 / IV	1 / IV	1 / IV	1 / IV	1 / IV	1 / IV	1 / IV	1 / IV	1 / IV	1 / IV	2 / III	2 / III
T.B.F. (cu yd)	1.5	1.5	1.7	2.1		0.4	0.6	0.5	1.7	0.6	0.6	0.6	4.1	3.7	0.6	11.7	1.7	3.8	6.1

RECONSTRUCT **ADJUST** **ADJUST** **ADJUST** **ADJUST**
 See Note 1 See Note 1 See Note 1 See Note 1 See Note 1

STR. NO.	C3	C154	C50	C153	C4	C160	C161	C162	C156	C5	C51	C155	C6	C53	C52	C110	C32	C109	C33
STATION	108+50.00	108+50.00	108+50.00	108+75.00	111+00.00	111+00.00	112+05.00	112+05.00	113+45.00	113+70.00	113+70.00	114+00.00	114+25.00	114+25.00	114+25.00	142+50.00	142+85.00	142+85.00	144+85.00
OFFSET (ft)	6.00 LT	14.70 LT	15.20 RT	14.70 RT	6.00 LT	14.70 LT	6.00 LT	14.70 LT	14.70 LT	6.00 LT	15.20 LT	14.70 RT	6.00 LT	14.70 LT	15.20 RT	42.00 RT	6.00 LT	15.40 RT	13.00 LT
TYPE	MH-A	INL-A	INL-B	INL-A	MH-A	INL-A	MH-A	INL-A	INL-A	MH-A	INL-B	INL-A	MH-A	INL-A	INL-B	INL-A	MH-A	INL-B	MH-A
DIA. (ft)	5.00	2.00	3.00	2.00	5.00	2.00	5.00	2.00	2.00	5.00	3.00	2.00	5.00	2.00	3.00	2.00	5.00	3.00	5.00
F&G	T1-CL	T3	T3	T3	T1-CL	T3	T1-CL	T3	T3	T1-CL	T3	T3	T1-CL	T3	T3	Special	T1-CL	T3	T1-CL
RIM EL.	628.04	627.80	627.80	629.05	639.01	638.77	641.02	640.78	640.75	640.82	640.58	640.38	640.44	640.20	640.20	698.24	699.13	698.89	700.83
INV. N	623.88		623.84		635.66		637.91		637.40	637.40		637.09		637.11		695.54		695.34	
INV. S	623.07	623.91			627.03	635.69		637.94		637.48		637.00		637.12			695.26	695.36	
INV. E	622.19		624.06		627.03		628.28		638.03	630.27	637.48	637.00		637.12			687.06	695.36	
INV. W	617.20			626.25	626.95		628.22		638.03	630.21	637.53	637.66		637.15			687.04		688.11

PIPE NO.	C154	C50	C153	C160	C162	C156	C51	C155	C53	C52	C110	C109	C33	C34	C146
SIZE (in)	12	12	12	12	12	12	12	12	12	12	12	12	30	30	12
LENGTH (ft)	6.00	17.00	23.00	6.00	6.00	23.00	5.00	23.00	6.00	17.00	42.00	17.00	195.00	197.00	50.00
TYPE/CLASS	1 / IV	1 / IV	1 / SS WM	1 / IV	1 / IV	1 / IV	1 / IV	1 / SS WM	1 / IV	1 / IV	1 / IV	1 / A	2 / III	2 / III	1 / IV
T.B.F. (cu yd)	1.2	4.4	3.0	0.7	0.6	2.1	0.7	2.1	0.7	2.2	8.6	2.9	405.7	330.1	3.6

- NOTES:
- MANHOLES C4, C161, C5, C6 & C32 PLACED IN PREVIOUS CONTRACT ONE ARE TO BE ADJUSTED OR RECONSTRUCTED TO RIM ELEVATIONS SHOWN IN BOLD.
 - IN PREVIOUS CONTRACT ONE, KNOCKOUTS WERE PROVIDED IN MANHOLES C2 THRU C6 AND C32 FOR INLET CONNECTIONS TO BE MADE IN THIS CONTRACT.
 - FOR F&G SHOWN AS SPECIAL, SEE DETAIL ON MISCELLANEOUS DETAIL SHEET.

LEGEND

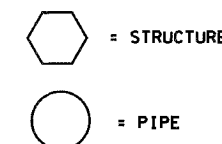

REVISIONS	
NAME	DATE

CITY OF DANVILLE, ILLINOIS
WINTER AVENUE RECONSTRUCTION
 PROPOSED STORM SEWER SCHEDULES
 STRUCTURES AND PIPES
 WINTER AVENUE

SCALE: NTS DATE: 12/21/06
 DRAWN BY: CGF CHECKED BY: ACW

DATE _____ BY _____
 SURVEYED _____ PLOTTED _____
 PLAN _____ CHECKED _____
 NOTE BOOK _____
 NO. _____
 CADD FILE NAME _____

STR. NO.	C146	C159	C116	C113	C34	C115	C111	C117	C112	C114	C35	C36	C118	C123	C120	C37	C122	C119	C124	C121	
STATION	146+25.00	146+50.00	146+77.44	146+77.44	146+87.44	146+87.44	146+87.44	146+97.44	146+97.44	147+07.18	147+81.07	148+77.00	148+77.00	149+83.10	149+83.10	149+93.10	149+93.10	149+93.10	149+93.10	150+03.10	150+03.10
OFFSET (ft)	32.70 RT	20.70 LT	21.55 LT	33.20 RT	13.00 LT	22.30 LT	33.20 RT	22.91 LT	33.20 RT	54.00 RT	13.00 LT	13.00 LT	32.70 LT	32.20 LT	20.70 RT	13.00 LT	31.71 LT	21.20 RT	30.21 LT	20.70 RT	
TYPE	INL-A	INL-A	INL-B	INL-B	MH-A	INL-B	INL-B	INL-A	INL-B	INL-A	MH-A	MH-A	INL-A	INL-A	INL-A	MH-A	INL-B	INL-B	INL-A	INL-A	
DIA. (ft)	2.00	2.00	3.00	3.00	5.00	3.00	3.00	2.00	3.00	2.00	5.00	4.00	2.00	2.00	2.00	4.00	3.00	3.00	2.00	2.00	
F&G	T3	T3	T3	T3	T1-CL	T3	T3	T3	T3	Special	T1-CL	T1-CL	T3	T3	T3	T1-CL	T3	T3	T3	T3	
RIM EL.	697.42	697.31	697.15	696.97	697.37	697.13	696.96	697.12	696.97	696.83	698.12	696.77	696.36	695.43	695.61	695.82	695.43	695.60	695.46	695.61	
INV. N					694.35		693.57			694.08	689.96	693.58			691.92	691.89	692.74				
INV. S					690.43	694.37			693.99		690.96		693.66		691.59	692.62		692.80			
INV. E	694.71	694.60	694.44	694.22	689.00	694.39	693.94				690.41	690.83		692.73	692.90	691.59	692.70	692.80			
INV. W			694.46	694.28	688.98	694.39	693.98	694.42	693.97		689.39	690.81			691.32	692.70	692.80	692.75		692.90	

PIPE NO.	C159	C116	C113	C115	C111	C117	C112	C114	C35	C36	C118	C37	C123	C120	C122	C119	C124	C121	C38
SIZE (in)	12	12	12	12	15	12	12	12	30	18	12	18	12	12	12	12	12	12	15
LENGTH (ft)	25.00	7.00	7.00	5.00	42.00	8.00	7.00	21.00	89.00	92.00	17.00	112.00	8.00	8.00	16.00	31.00	8.00	8.00	68.00
TYPE/CLASS	1 / IV	1 / IV	1 / IV	1 / IV	1 / A	1 / IV	1 / IV	1 / IV	2 / III	2 / A	1 / IV	1 / IV	1 / IV	1 / IV	1 / IV	1 / IV	1 / IV	1 / IV	1 / IV
T.B.F. (cu yd)	1.8	0.5	0.6	0.5	14.3	0.6	0.7	3.9	109.0	74.6	1.7	38.6	0.6	0.7	2.3	4.4	0.6	0.7	16.0

STR. NO.	C125	C38	C127	C129	D3	E1	E2	C167	D1	D2	C163	D4	C164	C39	C131	C130	C132	C133
STATION	150+45.00	150+64.71	150+64.71	150+64.71	59+78.00	59+78.00	60+08.00	60+08.00	60+08.00	60+62.00	61+07.50	61+07.50	61+07.50	62+50.00	62+50.00	62+50.00	62+50.00	62+50.00
OFFSET (ft)	34.05 LT	13.00 LT	24.55 LT	20.70 RT	19.70 LT	19.70 RT	20.20 RT	12.00 LT	20.20 LT	20.16 LT	12.00 LT	26.23 LT	19.70 RT	12.00 LT	38.20 LT	23.49 LT	32.55 RT	47.44 RT
TYPE	INL-A	MH-A	INL-B	INL-A	INL-A	INL-A	INL-B	MH-A	INL-B	INL-A	MH-A	INL-A	INL-A	MH-A	INL-A	INL-B	INL-B	INL-A
DIA. (ft)	2.00	4.00	3.00	2.00	2.00	2.00	3.00	4.00	3.00	2.00	4.00	2.00	2.00	5.00	2.00	3.00	3.00	2.00
F&G	Special	T1-CL	T3	T3	T3	T3	T3	T1-CL	T3	T3	T1-CL	T3	T3	T1-CL	Special	T3	T3	Special
RIM EL.	695.00	696.18	695.91	695.96	697.09	697.09	697.18	697.40	697.18	697.35	697.75	697.43	697.53	698.75	695.82	698.48	697.84	695.19
INV. N		691.91	691.96	693.23	694.29	694.29		693.76	693.96	694.55	693.29	693.35	694.58	691.97	691.04	693.03	692.84	691.80
INV. S	692.05	692.22	691.94				693.93	693.96	693.96		693.43		694.73	691.61	693.03	692.97	691.78	691.86
INV. E								693.78	693.91		693.53			692.30				
INV. W		691.89					693.90	693.81						692.30				

PIPE NO.	C125	C127	C129	D3	E2	E1	D1	D2	C167	D4	C164	C163	C39	C131	C130	C132	C133	C40
SIZE (in)	15	15	12	12	12	12	12	12	12	12	12	12	24	12	12	18	18	15
LENGTH (ft)	20.00	9.00	31.00	28.00	28.00	29.00	5.00	52.00	95.00	11.00	29.00	90.00	44.00	13.00	7.00	41.00	13.00	67.00
TYPE/CLASS	1 / IV	1 / IV	1 / IV	1 / SS WM	1 / SS WM	1 / IV	1 / IV	1 / SS WM	1 / IV	1 / IV	1 / IV	2 / A	2 / III	1 / IV	2 / III	2 / III	1 / A	1 / IV
T.B.F. (cu yd)	1.0	1.9	4.4	2.6	2.9	4.1	0.7	4.8	18.4	1.7	4.4	34.5	46.2	0.4	4.5	31.0	0.5	22.8

NOTE:
 1. FOR F&G SHOWN AS SPECIAL, SEE DETAIL ON MISCELLANEOUS DETAIL SHEET.

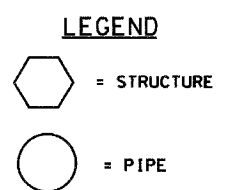

REVISIONS	
NAME	DATE

CITY OF DANVILLE, ILLINOIS
WINTER AVENUE RECONSTRUCTION
PROPOSED STORM SEWER SCHEDULES
STRUCTURES AND PIPES
WINTER AVENUE
BOWMAN AVENUE

SCALE: NTS
 DRAWN BY: CGF
 DATE: 12/21/06
 CHECKED BY: ACW

F.A.U. RTE.	SECTION	COUNTY	TOTAL SHEETS	SHEET NO.
6998	99-00209-01-PV	VERMILION	296	77
STA. 97+00		TO STA. 103+00		
FED. ROAD DIST. NO. ILLINOIS		FED. AID PROJECT-		
CONTRACT NO.: 91358				

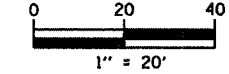

PLAN	SURVEYED	DATE
	BY	
	NOTED	
	CHECKED	
	RT. OF WAY CHECKED	
	CADD FILE NAME	

PROFILE	SURVEYED	DATE
	BY	
	NOTED	
	CHECKED	
	S.M. NOTED	
	STRUCTURE NOTATIONS CPFD	

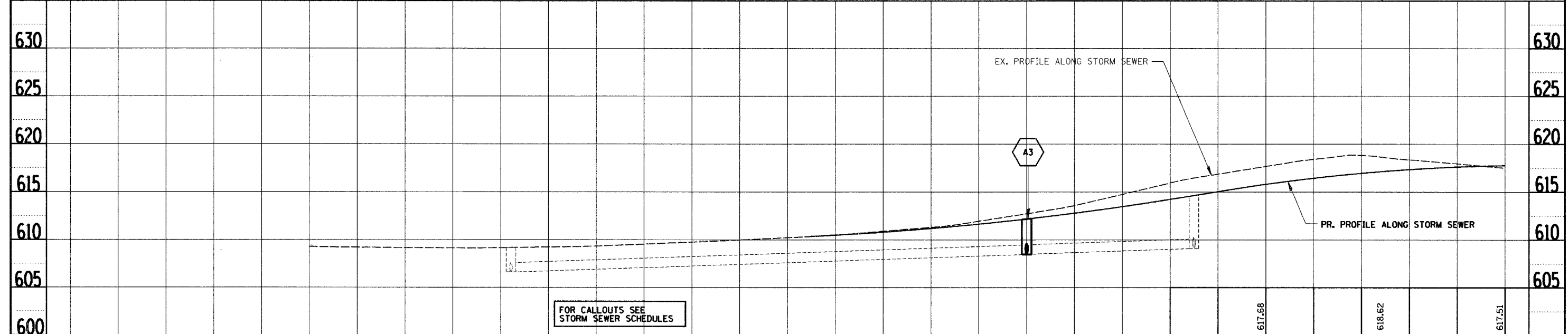
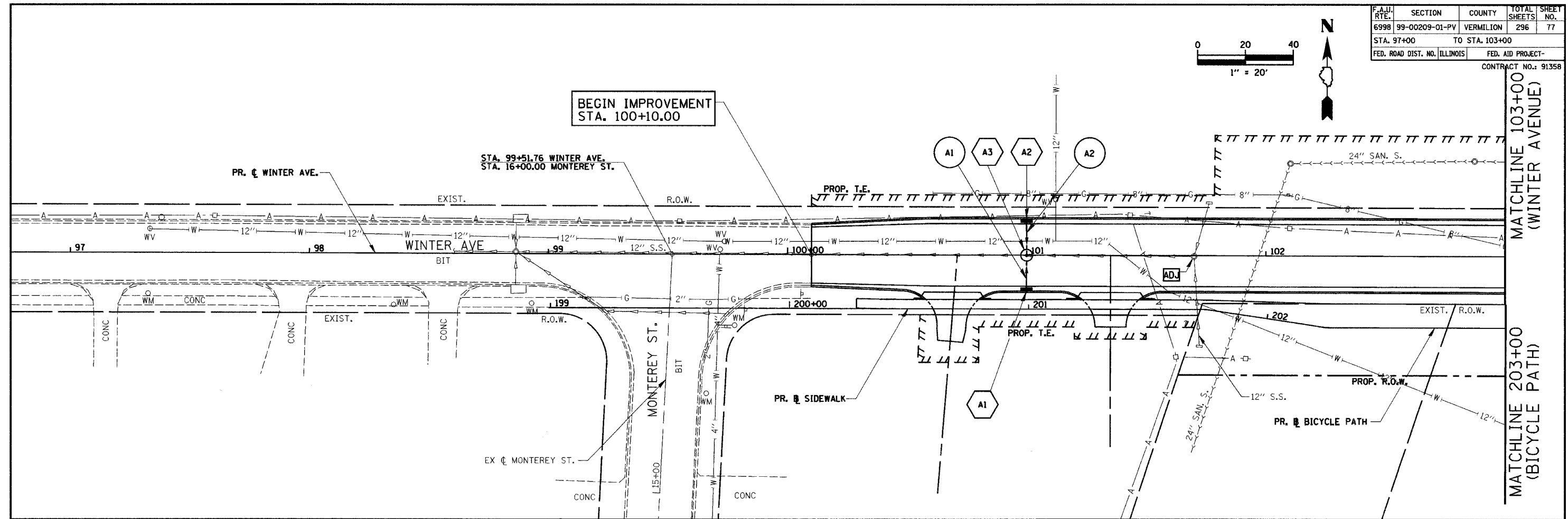

REVISIONS	NAME	DATE

CITY OF DANVILLE, ILLINOIS
**WINTER AVENUE RECONSTRUCTION
 PROPOSED DRAINAGE PLAN
 WINTER AVENUE/BICYCLE PATH
 STA. 97+00 TO STA. 103+00**

SCALE: 1/4" = 20' HORIZ.
 1/4" = 5' VERT.
 DRAWN BY: CGF
 DATE: 12/21/06
 CHECKED BY: TDN

PLAN	SURVEYED	DATE
	DESIGNED	
	CHECKED	
	BY	
	NO. OF WAYS CHECKED	
	CADD FILE NAME	

PROFILE	SURVEYED	DATE
	DESIGNED	
	CHECKED	
	BY	
	NO. OF WAYS CHECKED	
	STRUCTURE NOTATIONS GRID	

F.A.U. RTE.	SECTION	COUNTY	TOTAL SHEETS	SHEET NO.
6998	99-00209-01-PV	VERMILION	296	78
STA. 103+00	TO STA. 109+00			
FED. ROAD DIST. NO. ILLINOIS	FED. AID PROJECT-			
	CONTRACT NO. 91358			

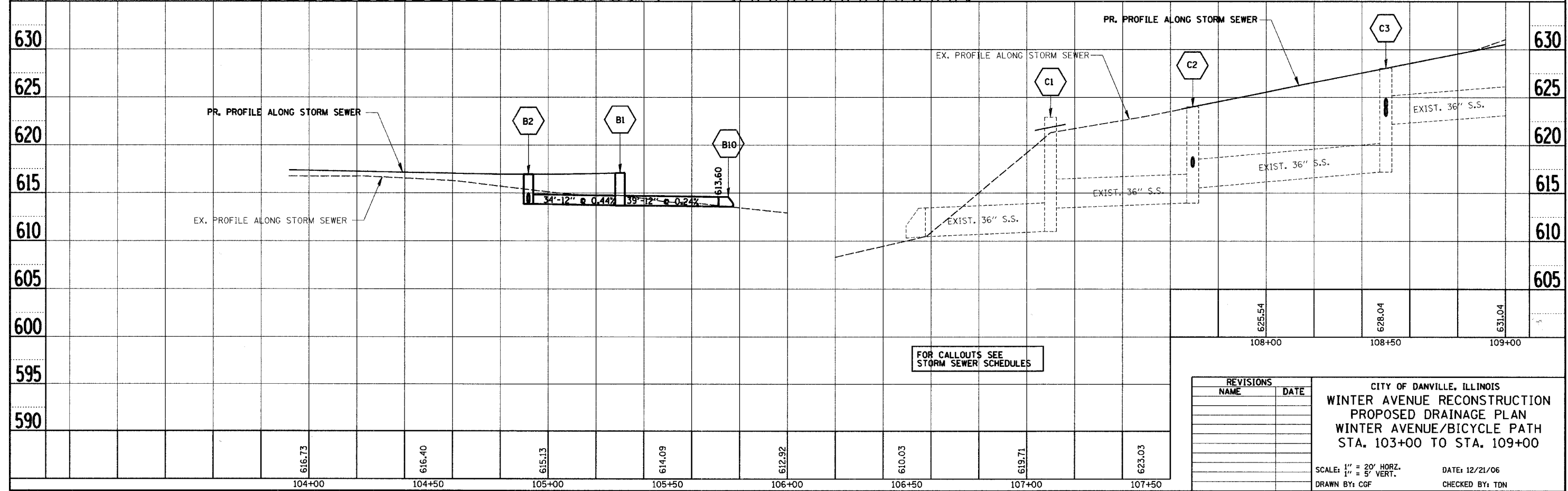
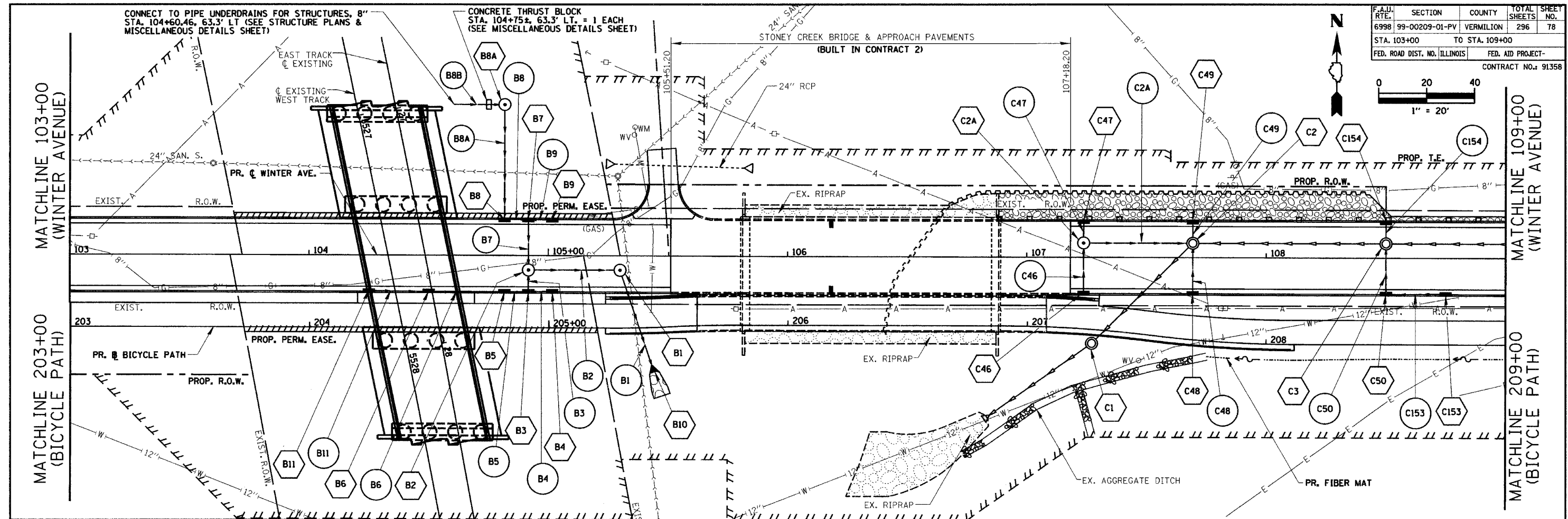
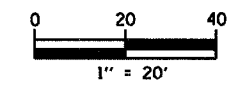

REVISIONS	
NAME	DATE

CITY OF DANVILLE, ILLINOIS
**WINTER AVENUE RECONSTRUCTION
 PROPOSED DRAINAGE PLAN
 WINTER AVENUE/BICYCLE PATH
 STA. 103+00 TO STA. 109+00**

SCALE: 1" = 20' HORIZ.
 1" = 5' VERT.
 DRAWN BY: CGF
 DATE: 12/21/06
 CHECKED BY: TDN

F.A.D. RTE.	SECTION	COUNTY	TOTAL SHEETS	SHEET NO.
6998	99-00209-01-PV	VERMILION	296	79
STA. 109+00		TO STA. 115+00		
FED. ROAD DIST. NO. ILLINOIS		FED. AID PROJECT-		
CONTRACT NO.: 91358				

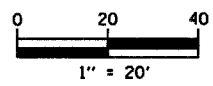

PLAN	SURVEYED	DATE
NO.	BY	
	CHECKED	
	DATE	
	BY	
	CHECKED	
	DATE	

MATCHLINE 109+00 (WINTER AVENUE)

MATCHLINE 209+00 (BICYCLE PATH)

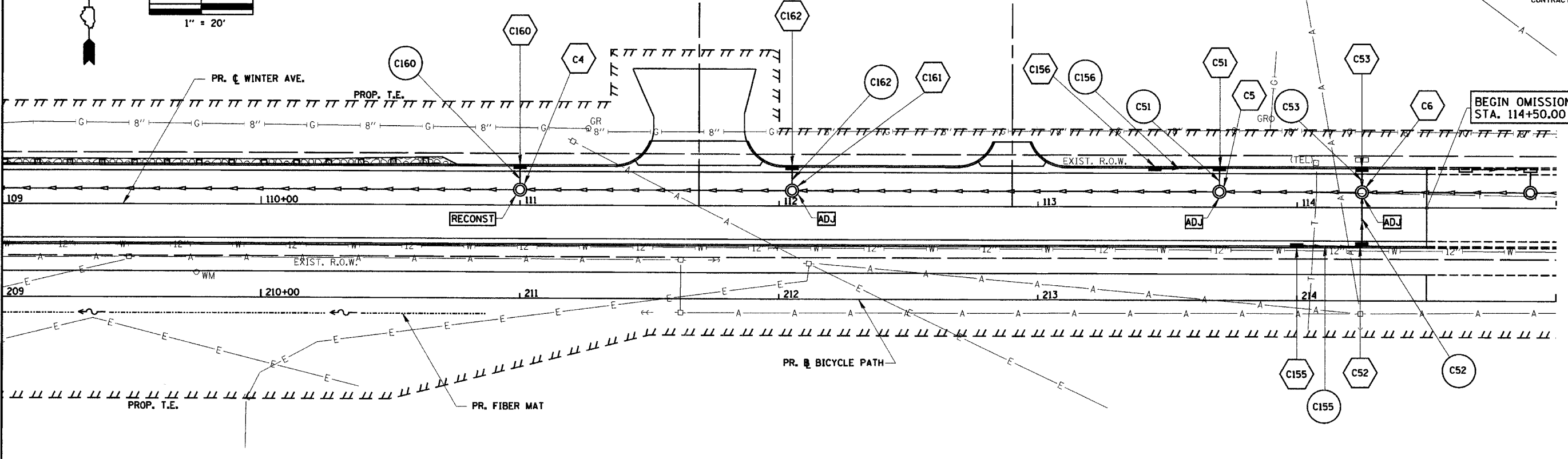

PROFILE	SURVEYED	DATE
NO.	BY	
	CHECKED	
	DATE	
	BY	
	CHECKED	
	DATE	

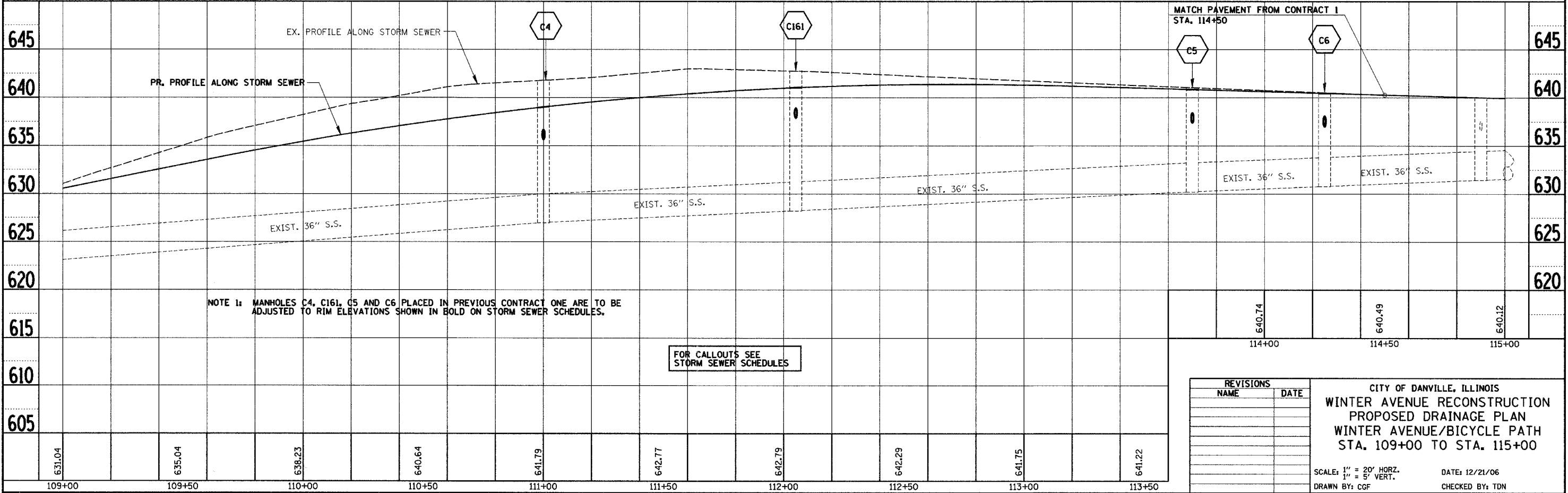

REVISIONS	
NAME	DATE

CITY OF DANVILLE, ILLINOIS
**WINTER AVENUE RECONSTRUCTION
 PROPOSED DRAINAGE PLAN
 WINTER AVENUE/BICYCLE PATH
 STA. 109+00 TO STA. 115+00**

SCALE: 1" = 20' HORIZ.
 1" = 5' VERT.
 DRAWN BY: CGF
 DATE: 12/21/06
 CHECKED BY: TDN

631.04	635.04	638.23	640.64	641.79	642.77	642.79	642.29	641.75	641.22
109+00	109+50	110+00	110+50	111+00	111+50	112+00	112+50	113+00	113+50

F.A.I.D. NO.	SECTION	COUNTY	TOTAL SHEETS	SHEET NO.
6998	99-00209-01-PV	VERMILION	296	80
STA. 139+00	TO STA. 145+00			
FED. ROAD DIST. NO. ILLINOIS	FED. AID PROJECT-			
CONTRACT NO.: 91358				

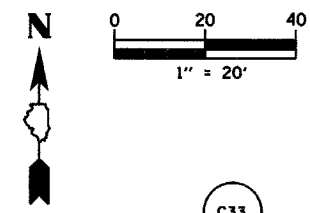

PLAN	SURVEYED	DATE
	BY	
	NOTED	
	PLANNED	
	DESIGNED	
	CHECKED	
	BY	
	DATE	

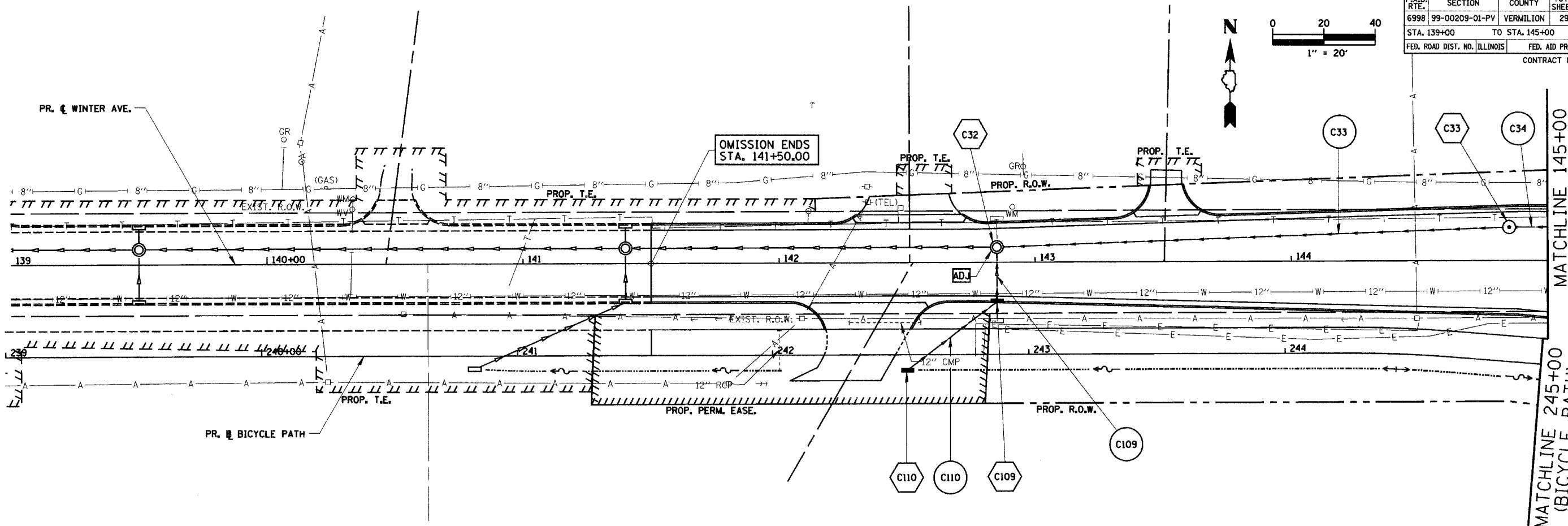

PROFILE	SURVEYED	DATE
	BY	
	NOTED	
	PLANNED	
	DESIGNED	
	CHECKED	
	BY	
	DATE	

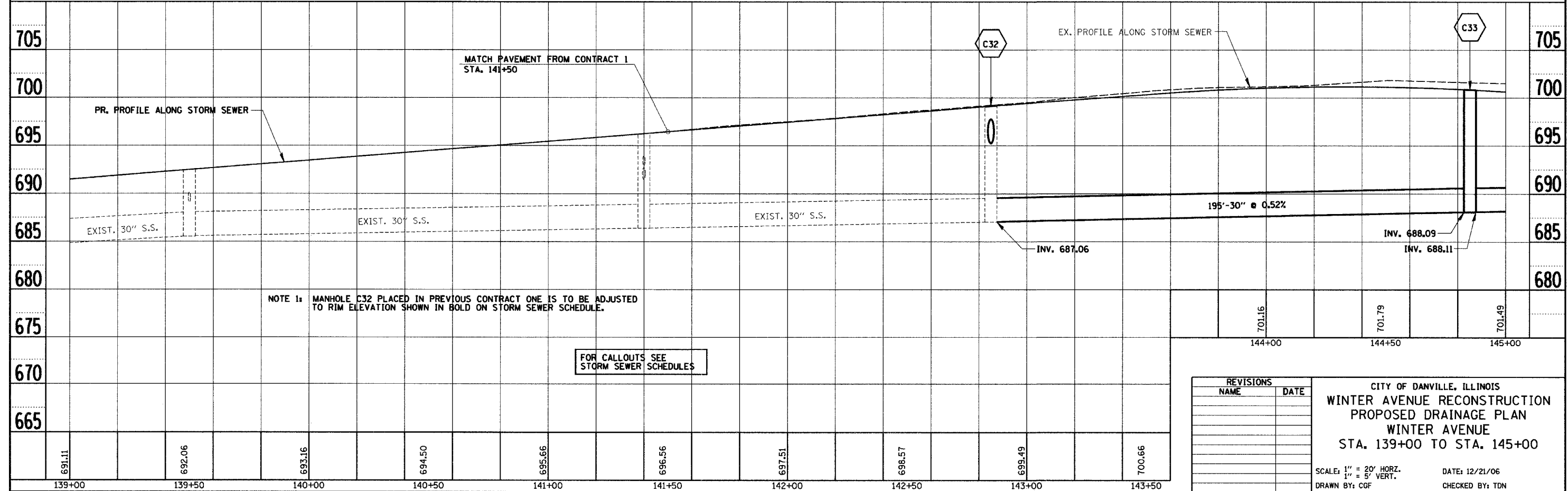

NOTE 1: MANHOLE C32 PLACED IN PREVIOUS CONTRACT ONE IS TO BE ADJUSTED TO RIM ELEVATION SHOWN IN BOLD ON STORM SEWER SCHEDULE.

FOR CALLOUTS SEE STORM SEWER SCHEDULES

REVISIONS	
NAME	DATE

CITY OF DANVILLE, ILLINOIS
WINTER AVENUE RECONSTRUCTION
PROPOSED DRAINAGE PLAN
WINTER AVENUE
STA. 139+00 TO STA. 145+00

SCALE: 1" = 20' HORIZ.
1" = 5' VERT.

DATE: 12/21/06
DRAWN BY: CGF
CHECKED BY: TDN

691.11	692.06	693.16	694.50	695.66	696.56	697.51	698.57	699.49	700.66
139+00	139+50	140+00	140+50	141+00	141+50	142+00	142+50	143+00	143+50

F.A.D. NO.	SECTION	COUNTY	TOTAL SHEETS	SHEET NO.
6998	99-00209-01-PV	VERMILION	296	81
STA. 145+00		TO STA. 151+00		
FED. ROAD DIST. NO. ILLINOIS		FED. AID PROJECT-		
CONTRACT NO.: 91358				

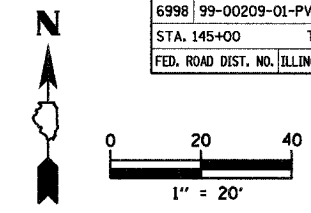

PLAN	SURVEYED	DATE
	BY	
	NOTED	
	REVISIONS	
	NO.	

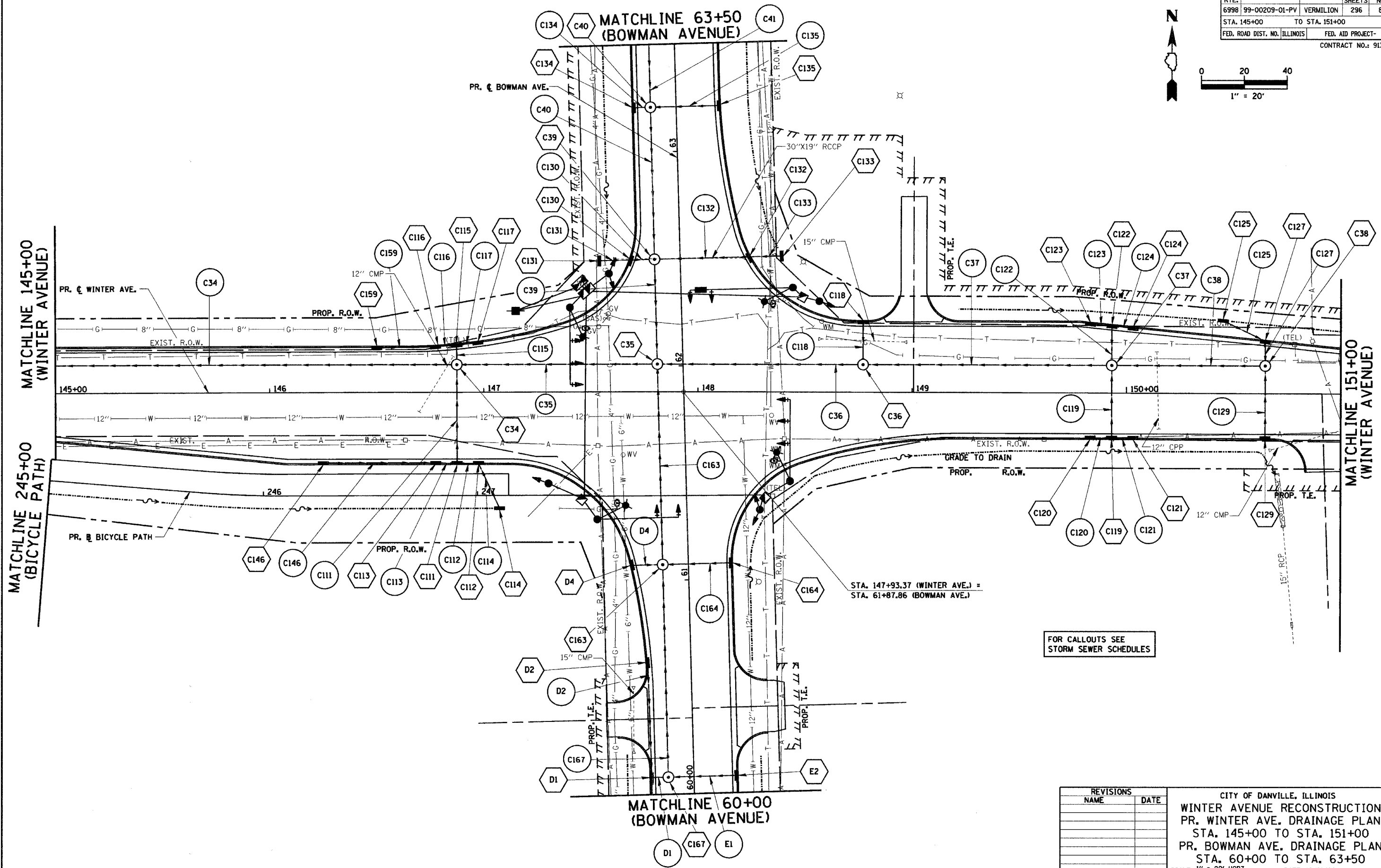

FOR CALLOUTS SEE STORM SEWER SCHEDULES

STA. 147+93.37 (WINTER AVE.) = STA. 61+87.86 (BOWMAN AVE.)

REVISIONS	
NAME	DATE

CITY OF DANVILLE, ILLINOIS
 WINTER AVENUE RECONSTRUCTION
 PR. WINTER AVE. DRAINAGE PLAN
 STA. 145+00 TO STA. 151+00
 PR. BOWMAN AVE. DRAINAGE PLAN
 STA. 60+00 TO STA. 63+50
 SCALE: 1" = 20' HORIZ.
 1" = 5' VERT.
 DATE: 12/21/06
 DRAWN BY: CGF
 CHECKED BY: TDN

DATE	
BY	
PROFILER	
CHECKED	
DATE	
BY	
NOTE BOOK	
NO.	

DATE	
BY	
PROFILER	
CHECKED	
DATE	
BY	
NOTE BOOK	
NO.	

F.A.I. RTE.	SECTION	COUNTY	TOTAL SHEETS	SHEET NO.
6998	99-00209-01-PV	VERMILION	296	82
STA. 145+00	TO STA. 151+00			
FED. ROAD DIST. NO. ILLINOIS	FED. AID PROJECT-		CONTRACT NO.: 91358	

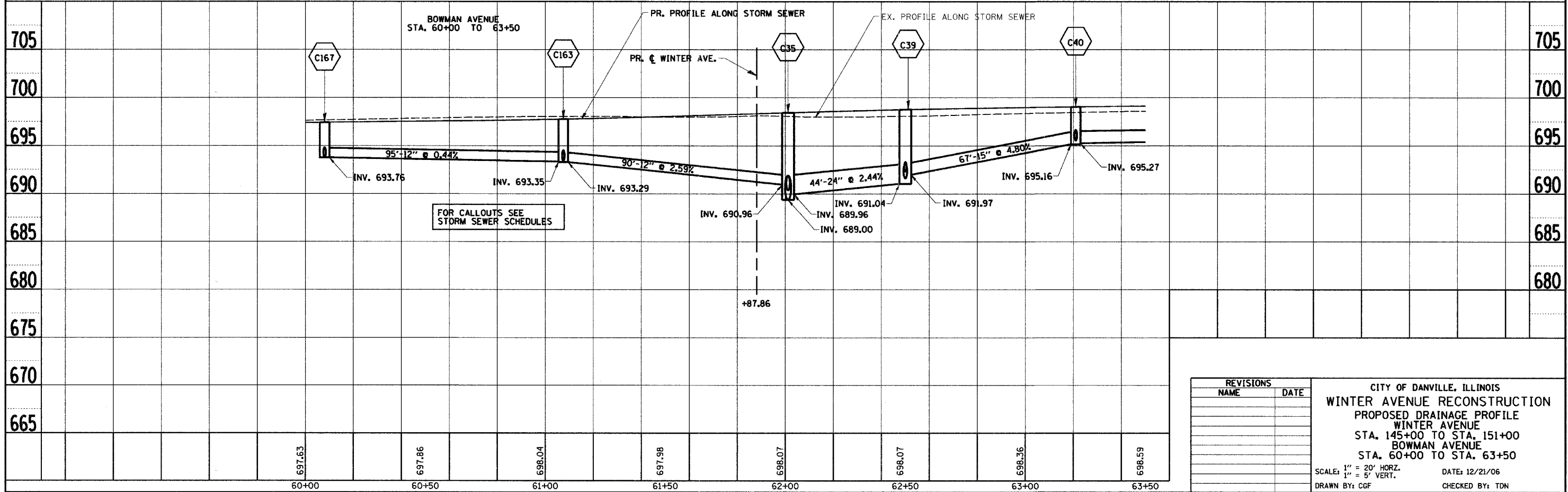
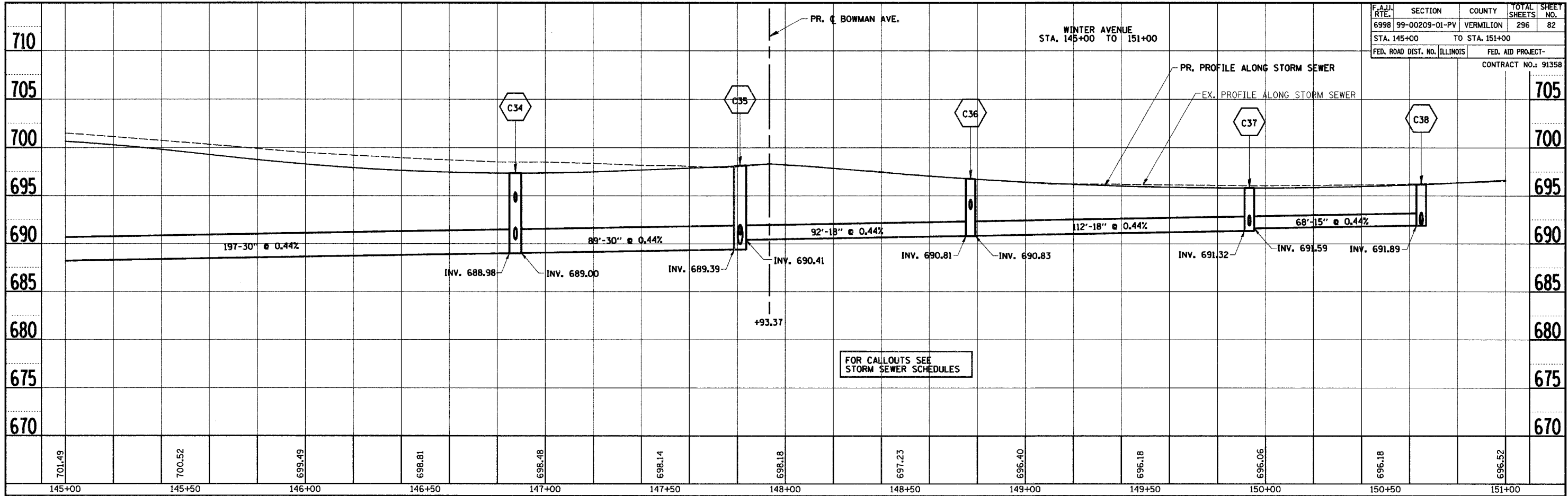

REVISIONS	
NAME	DATE

CITY OF DANVILLE, ILLINOIS
WINTER AVENUE RECONSTRUCTION
 PROPOSED DRAINAGE PROFILE
 WINTER AVENUE
 STA. 145+00 TO STA. 151+00
 BOWMAN AVENUE
 STA. 60+00 TO STA. 63+50

SCALE: 1" = 20' HORZ.
 1" = 5' VERT.

DATE: 12/21/06
 DRAWN BY: CGF
 CHECKED BY: TDN

F.A.I.D. NO.	SECTION	COUNTY	TOTAL SHEETS	SHEET NO.
6998	99-00209-01-PV	VERMILION	296	83
STA. 151+00		TO STA. 157+00		
FED. ROAD DIST. NO. ILLINOIS		FED. AID PROJECT-		
CONTRACT NO.: 91358				

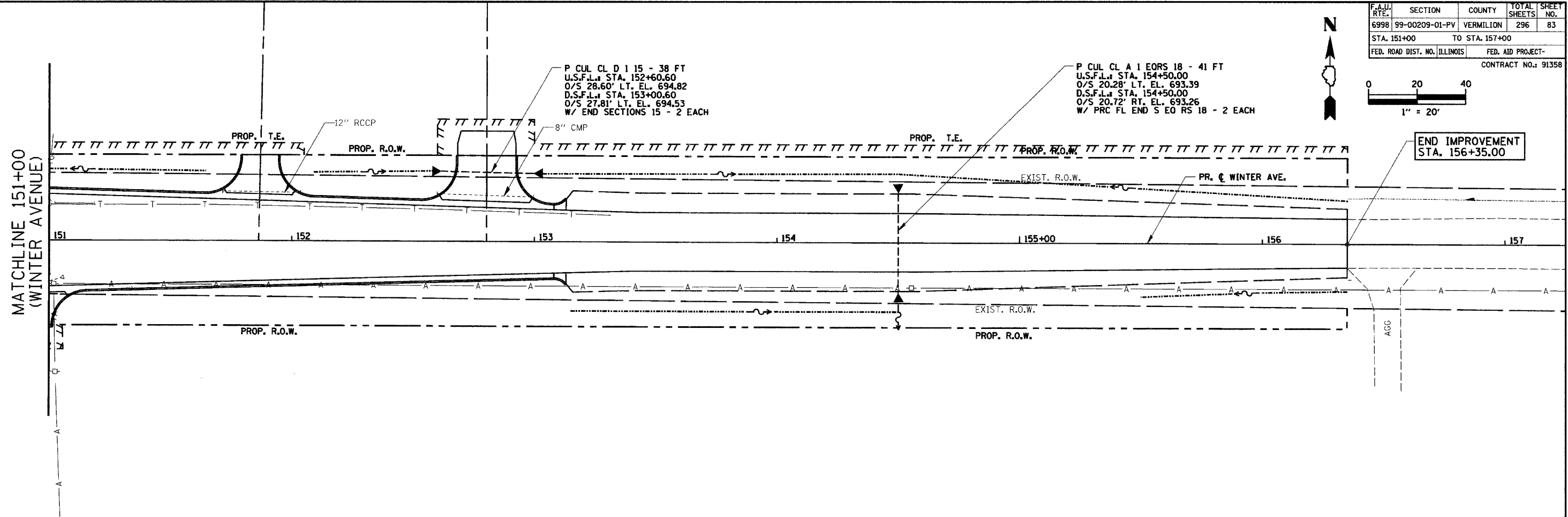
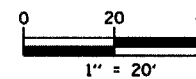

PLAN	SURVEYED	DATE
	BY	
	NOTED	
	BY	
	NOTED	
	BY	
	NOTED	

PROFILE	SURVEYED	DATE
	BY	
	NOTED	
	BY	
	NOTED	
	BY	
	NOTED	

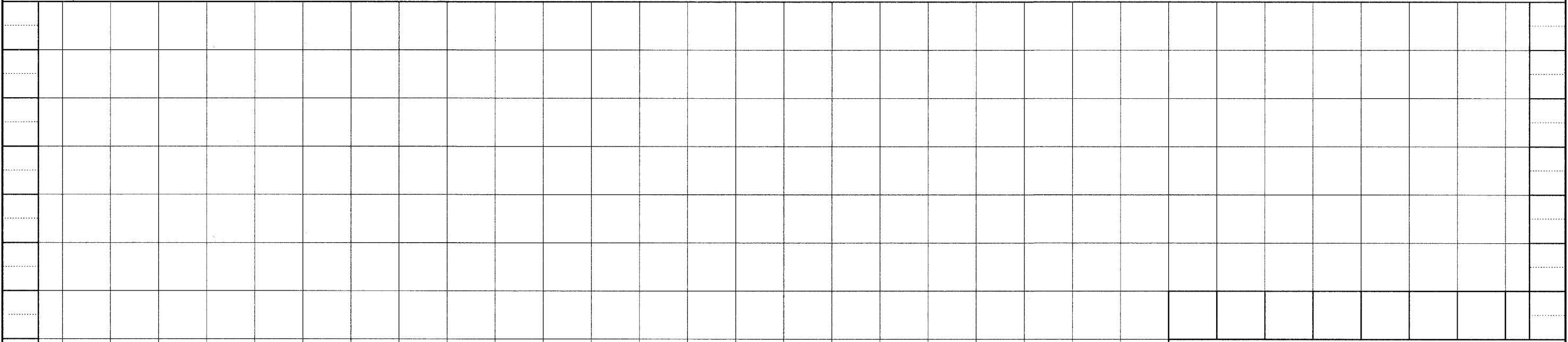

REVISIONS	
NAME	DATE

CITY OF DANVILLE, ILLINOIS
WINTER AVENUE RECONSTRUCTION
PROPOSED DRAINAGE PLAN
WINTER AVENUE
STA. 151+00 TO STA. 157+00

SCALE: 1" = 20' HORIZ.
1" = 5' VERT.

DATE: 12/21/06
DRAWN BY: CGF
CHECKED BY: TDN

F.A.D. RTE.	SECTION	COUNTY	TOTAL SHEETS	SHEET NO.
6998	99-00209-01-PV	VERMILION	296	84
STA. 54+00		TO STA. 60+00		
FED. ROAD DIST. NO. ILLINOIS		FED. AID PROJECT-		

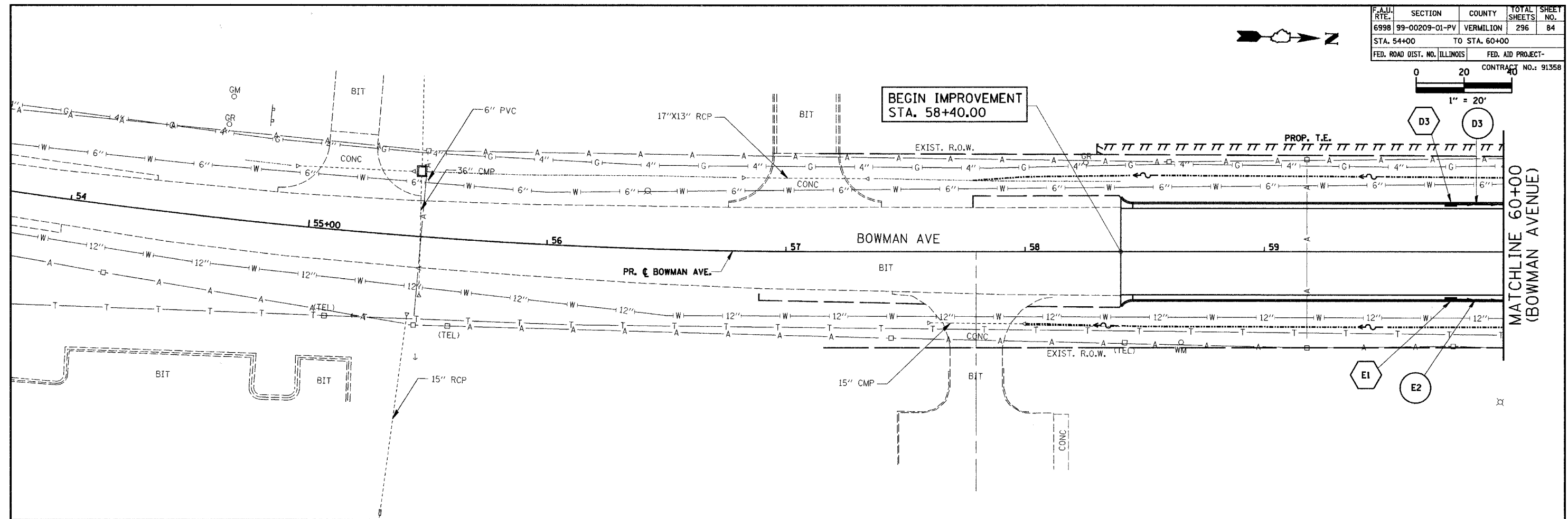
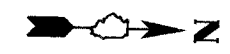
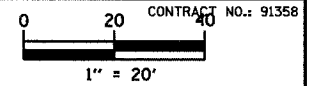

PLAN	SURVEYED	DATE
	BY	
	NOTED	
	CHECKED	
	REVISIONS	
	NO. OF WAYS CHECKED	
	CADD FILE NAME	
	NO.	

PROFILE	SURVEYED	DATE
	BY	
	NOTED	
	CHECKED	
	REVISIONS	
	STRUCTURE NOTATION	
	CRNO	
	NO.	

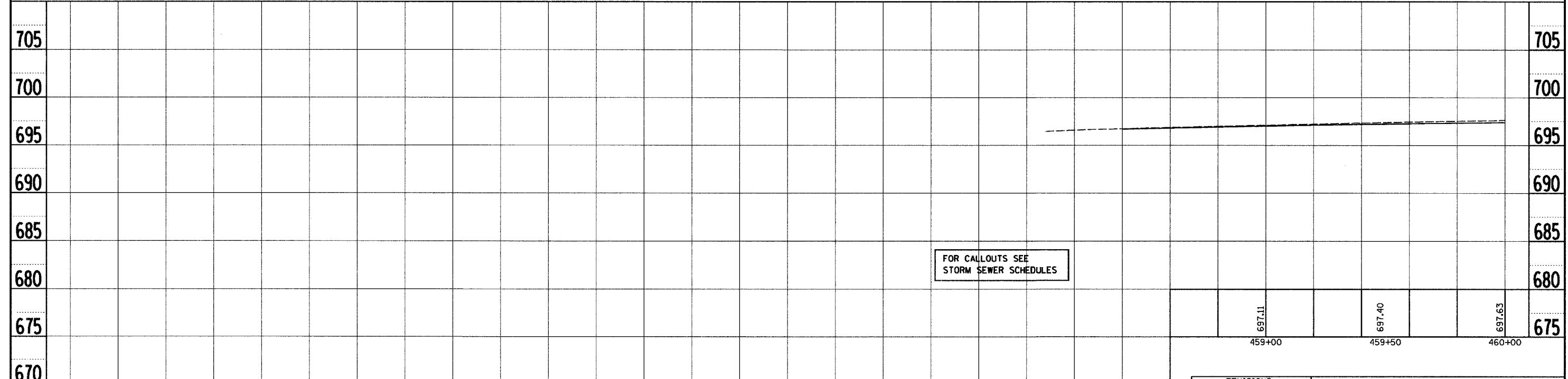

REVISIONS		DATE
NAME		

CITY OF DANVILLE, ILLINOIS
WINTER AVENUE RECONSTRUCTION
PROPOSED DRAINAGE PLAN
BOWMAN AVENUE
STA. 54+00 TO STA. 60+00

SCALE: 1" = 20' HORIZ.
1" = 5' VERT.
DRAWN BY: CGF
DATE: 12/21/06
CHECKED BY: TDN

18-96-81
458+50

DETAIL OF MAILBOX TURNOUT IN CURB AND GUTTER SECTION

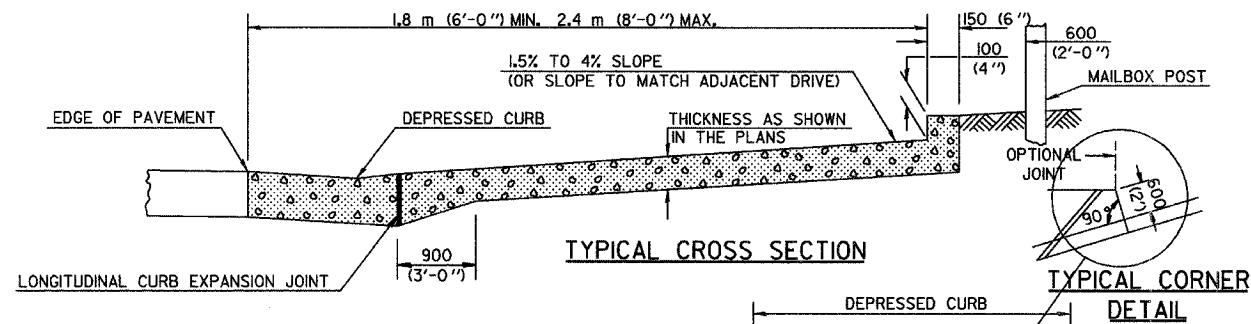

- GENERAL NOTES**
1. THE LONGITUDINAL CURB EXPANSION JOINT SHALL CONFORM TO SECTION 105I(715) OF THE STANDARD SPECIFICATIONS.
 2. THE MAILBOX TURNOUT CROSS SLOPE WILL BE AS SHOWN ABOVE, AS SHOWN ON THE STATION CROSS SECTIONS, OR AS DIRECTED BY THE ENGINEER.
 3. THE MAILBOX TURNOUT SHALL BE CONSTRUCTED WITH SCORED GROOVES, AS SPECIFIED IN ARTICLE 606.06 OF THE STANDARD SPECIFICATIONS, AT APPROXIMATELY 3m (10') CENTERS. IN THE EVENT THERE IS EXISTING OR PROPOSED SIDEWALK PRESENT, THESE SCORED GROOVES SHALL BE PLACED IN LINE WITH EVERY OTHER JOINT IN THE ADJACENT SIDEWALK.
 4. THIS WORK WILL BE PAID FOR AT THE CONTRACT UNIT PRICE PER SQUARE METER FOR P.C. CONCRETE DRIVEWAY PAVEMENT OF THE THICKNESS SPECIFIED IN THE PLANS WHICH SHALL INCLUDE THE LONGITUDINAL CURB EXPANSION JOINT, MONOLITHIC CURB AS SHOWN, SCORED GROOVES, AND THE ADDITIONAL THICKNESS REQUIRED ADJACENT TO THE DEPRESSED COMBINATION CONCRETE CURB AND NO ADDITIONAL COMPENSATION WILL BE ALLOWED.
 5. ALL THE DIMENSIONS ARE IN MILLIMETERS UNLESS OTHERWISE NOTED.

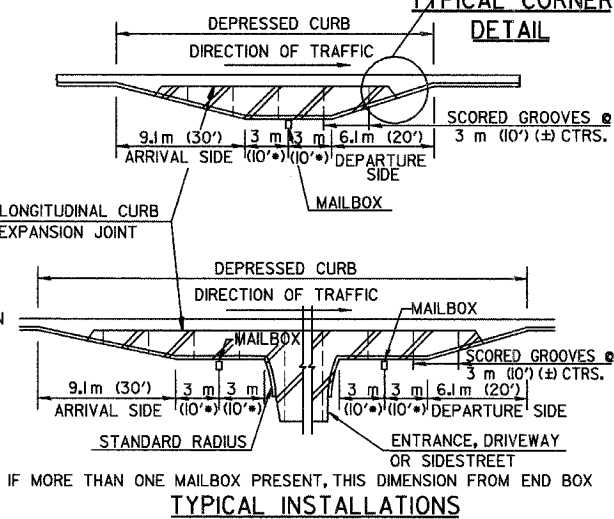

DESIGNED	J.H.M.	6/88	NAME	DATE
CHECKED	F.M.S.	6/88	J.H.M.	10/88
CADD NO.	A-LII		J.H.M.	9/89
			D.L.P.	10/96

DETAIL OF SPECIAL INLET FOR COMBINATION CONCRETE CURB AND GUTTER (BARRIER CURB)

F.A.U. RTE.	SECTION	COUNTY	TOTAL SHEETS	SHEET NO.
6998	99-00209-01-PV	VERMILION	296	86
STA. N/A	TO STA. N/A			
FED. ROAD DIST. NO. ILLINOIS	FED. AID PROJECT-			

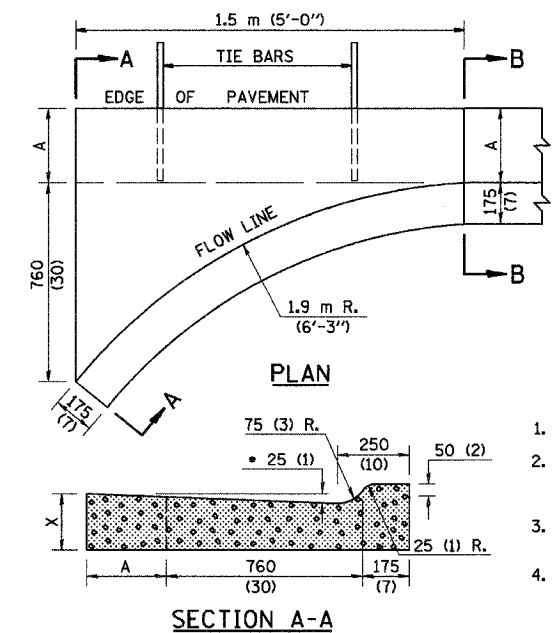

CONVERSION

150 mm = (6")	B-15.30 (B-6J2)	B-22.30 (B-9J2)	B-15.45 (B-6J8)	B-22.45 (B-9J8)	B-15.60 (B-6J24)	B-22.60 (B-9J24)
225 mm = (9")	A	300	300	450	450	600
250 mm = (10")	B	150	150	225	225	150
300 mm = (12")	X	225	250	225	250	225
450 mm = (18")	m	0.28	0.32	0.29	0.32	0.34
600 mm = (24")	(CU. YDS.)	(0.37)	(0.42)	(0.38)	(0.42)	(0.44)
		(0.44)	(0.49)	(0.45)	(0.50)	(0.50)
		(0.52)	(0.57)			

CLASS SI CONCRETE (OUTLETS)

GENERAL NOTES

1. CLASS SI CONCRETE SHALL BE USED THROUGHOUT.
2. TIE BARS SHALL BE NO. 20 (NO. 6) AT 600 mm (24") CENTERS UNLESS OTHERWISE SHOWN. SPECIAL INLETS AND OUTLETS SHALL BE TIED TO THE PAVEMENT IN ACCORDANCE WITH DETAILS FOR LONGITUDINAL CONSTRUCTION JOINT SHOWN ON STANDARD 420001.
3. TIE BARS SHOWN ABOVE WILL NOT BE PAID FOR SEPARATELY BUT SHALL BE CONSIDERED AS INCIDENTAL TO CLASS SI CONCRETE OUTLETS.
4. WHEN SPECIAL INLET IS CONSTRUCTED ADJACENT TO FLEXIBLE PAVEMENT, THE TIE BARS SHALL BE OMITTED AND ALL CONSTRUCTION JOINTS SHALL BE PROVIDED WITH A DOWELBAR CONFORMING TO ARTICLE 1006.11(b) [(706.11(b))].
5. THIS WORK WILL BE PAID FOR AT THE CONTRACT UNIT PRICE PER m (CU. YD.) FOR CLASS SI CONCRETE (OUTLETS) WHICH PRICE SHALL INCLUDE ALL LABOR AND MATERIAL AS SPECIFIED AND NO ADDITIONAL COMPENSATION WILL BE ALLOWED.

DESIGNED	J.H.M.	6/88	NAME	DATE
CHECKED	P.E.K.	6/88	G.A.M. (metric)	10/95
CADD NO.	A-2.01		D.L.P.	10/96

DETAIL OF DEPRESSING GUTTER GRADE AT INLETS, CATCH BASINS AND MANHOLES

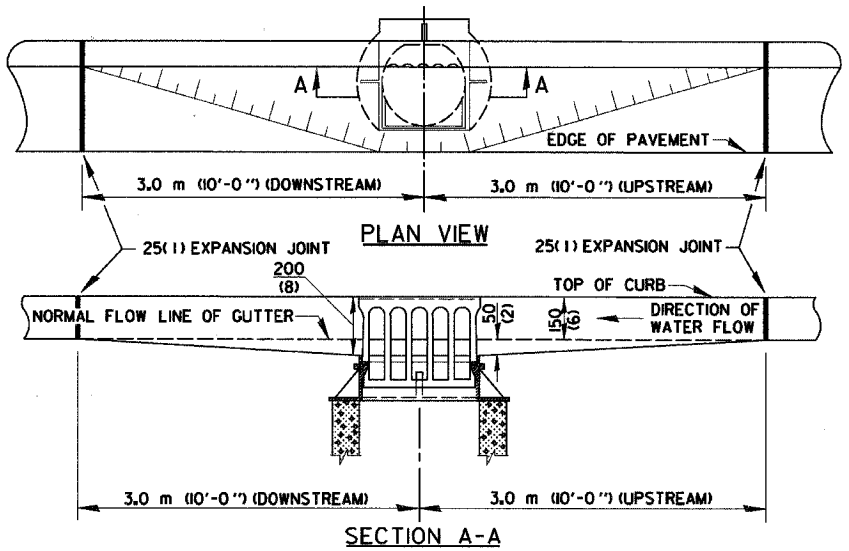

- GENERAL NOTES**
1. THE TWO EXPANSION JOINTS AS MENTIONED IN THE DRAINAGE OPENING PARAGRAPH ON STD. 606001 (2130) SHALL BE PLACED AS SHOWN ABOVE.
 2. THE GUTTER GRADE SHALL BE DEPRESSED AT ALL INLETS, CATCH BASINS AND MANHOLES UNLESS OTHERWISE SPECIFIED IN THE PLANS.
 3. THE COST OF THIS WORK SHALL BE INCLUDED IN THE COST OF THE VARIOUS PAY ITEMS OF WORK INVOLVED.
 4. ALL DIMENSIONS ARE IN MILLIMETERS (INCHES) UNLESS OTHERWISE NOTED.

DESIGNED	J.M.H.	11/87	NAME	DATE
CHECKED	F.M.S.	11/87	J.M.H.	7/88
CADD NO.	A-L32		D.L.P.	7/96
			D.L.P.	10/96

REVISIONS		CITY OF DANVILLE, ILLINOIS WINTER AVENUE RECONSTRUCTION
NAME	DATE	
		IDOT DISTRICT 5 CADD DETAILS
		SCALE: N/A
		DATE: 12/21/06
		DRAWN BY: SRS
		CHECKED BY: MBF

DETAIL OF SURVEY MONUMENT COVER ASSEMBLY

TO BE INSTALLED OVER EXISTING MARKERS FOR LAND SURVEY MONUMENT, P.C.'S, P.L.'S AND P.T.'S AT LOCATIONS SHOWN ON PLANS

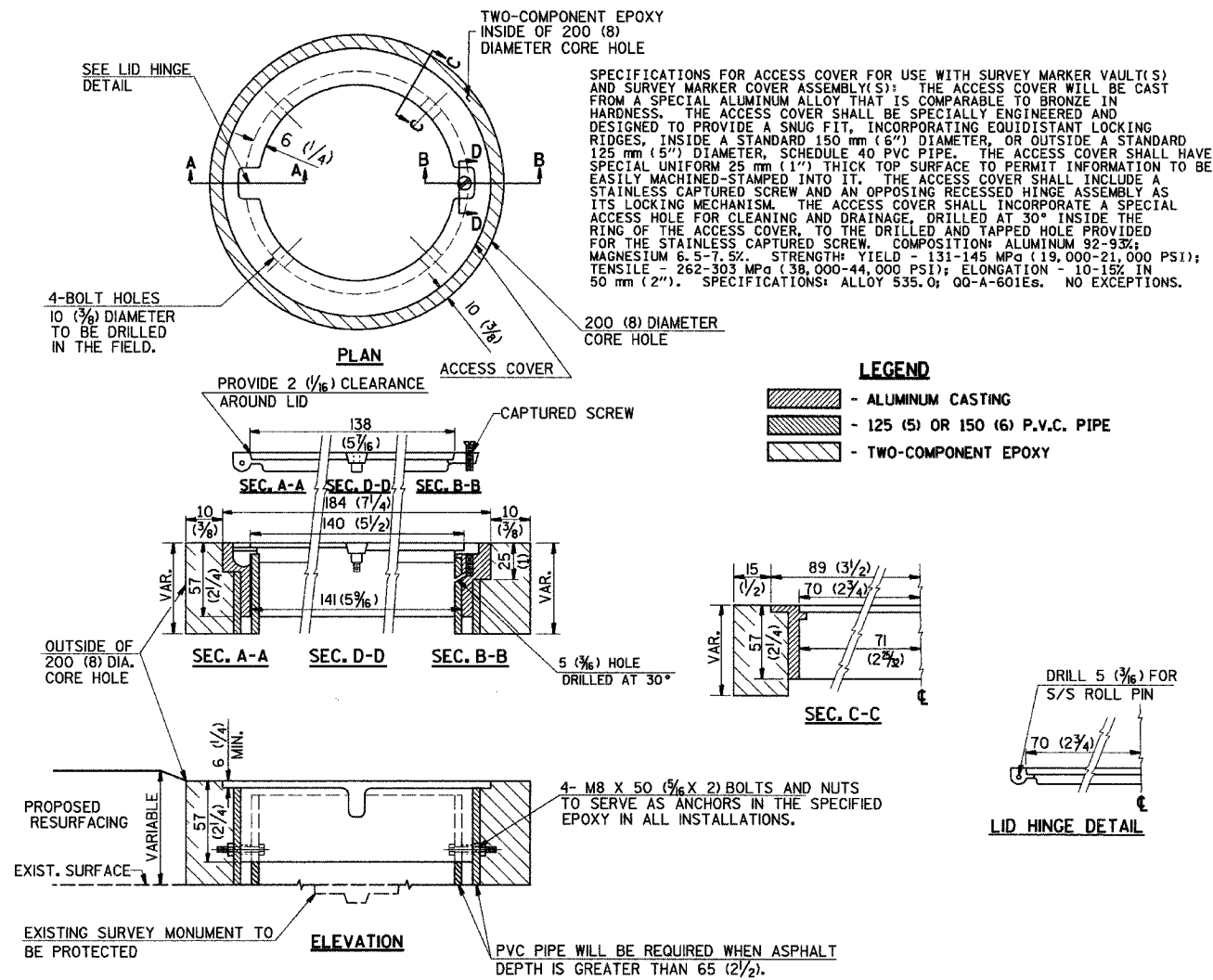

GENERAL NOTES

- WORK SHALL NOT START ON THIS ITEM UNTIL THE FINAL LIFT OF CLASS I HAS BEEN COMPLETED.
- THE SURVEY MONUMENT COVER ASSEMBLY SHALL BE CENTERED ABOVE THE SURVEY MONUMENT TO BE PROTECTED.
- MODIFICATION OF THE ALUMINUM CASTING SHALL BE DONE BY GRINDING OR SAWING WHEN HEIGHT REDUCTION IS REQUIRED.
- ALL SURVEY MONUMENT COVER ASSEMBLIES SHALL BE PLACED 6 mm (1/4") ± BELOW THE FINAL SURFACE.
- ALUMINUM CASTING SHALL BE PLACED OVER A 125 mm (5") P.V.C. PIPE OR INSIDE OF A 150 mm (6") P.V.C. PIPE WHEN AN INCREASE IN HEIGHT IS REQUIRED.
- THE CASTING SHALL BE ANCHORED IN THE 200 mm (8") DIAMETER CORE HOLE WITH TWO-COMPONENT EPOXY CONFORMING TO APPLICABLE PORTIONS OF ARTICLE 1025.01 (725.01) OF THE STANDARD SPECIFICATIONS.
- THIS WORK WILL BE PAID FOR AT THE CONTRACT UNIT PRICE EACH FOR SURVEY MONUMENT COVER ASSEMBLY WHICH PRICE SHALL INCLUDE ALL LABOR AND MATERIAL AS SPECIFIED INCLUDING CORING THE NEW PAVEMENT SURFACE AND EPOXY. NO ADDITIONAL COMPENSATION WILL BE ALLOWED.
- THE 200 mm (8") DIAMETER CORE HOLE SHALL BE SUBJECT TO THE APPROVAL OF THE ENGINEER.

BILL OF MATERIAL

ALUMINUM CASTING OF THE DIMENSIONS AND SPECIFICATIONS SHOWN OR OTHER SUBJECT TO ENGINEER'S APPROVAL OF SHOP DRAWINGS, 4 EACH - M8 X 50 (3/16" X 2") BOLTS WITH NUTS, EPOXY, 125 mm OR 150 mm (5" OR 6") P.V.C. PIPE, SCHEDULE 40 (WHEN REQUIRED).

DESIGNED		CHECKED		CADD NO.	
NAME	DATE	NAME	DATE	NAME	DATE
A.W.H.	2-28-91	A.W. HAYES	8-22-91	D-104	
		G.A.M.	11-95		

DETAIL OF SURVEY MARKER VAULT

FOR RESET LAND SURVEY MONUMENTS IN RIGID AND COMPOSITE PAVEMENTS

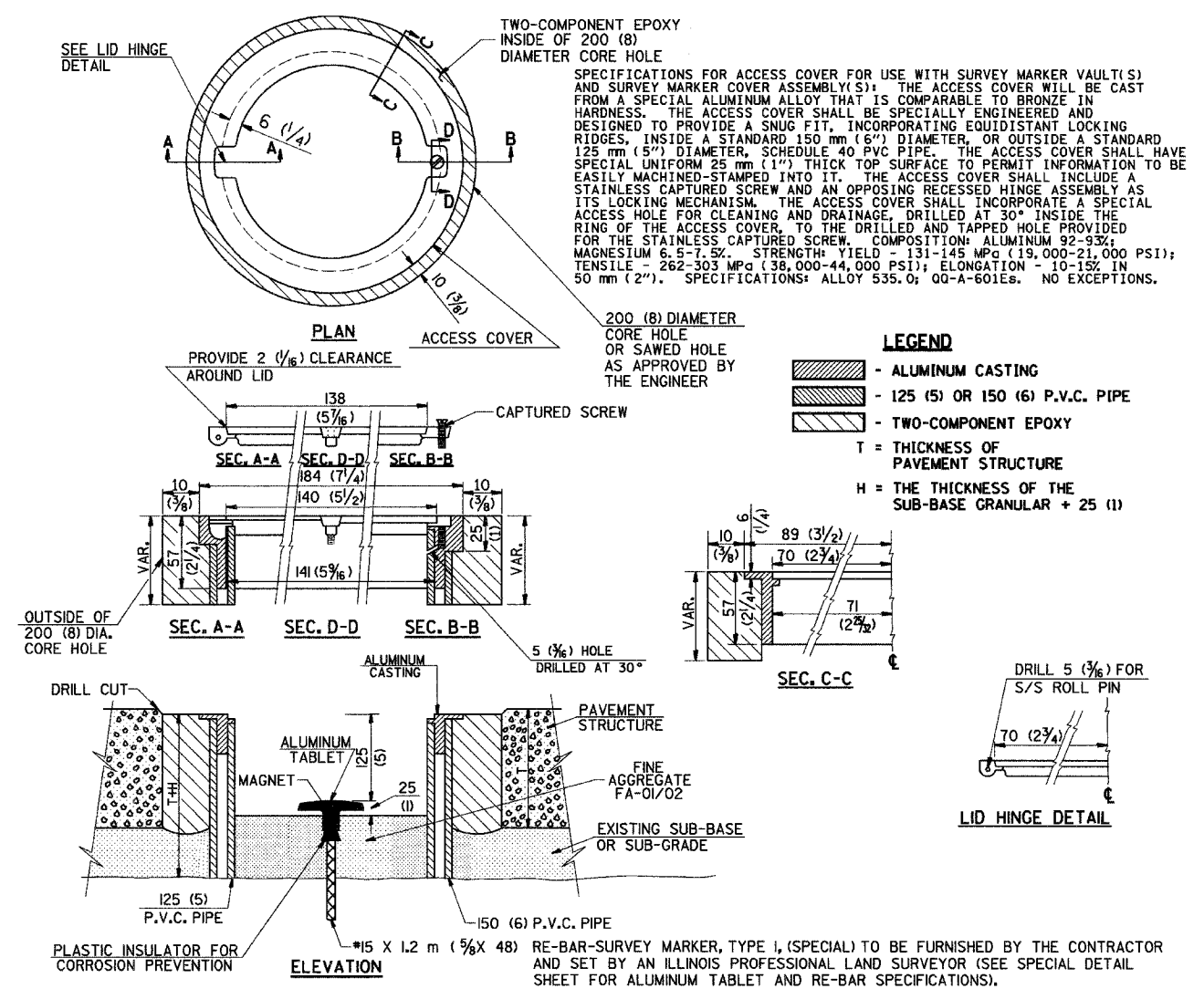

GENERAL NOTES

- ALUMINUM CASTING SHALL BE EITHER PLACED OVER A 125 mm (5") P.V.C. PIPE OR INSIDE OF A 150 mm (6") P.V.C. PIPE.
- BACKFILL WITH FINE AGGREGATE-FA-01/02.
- WORK SHALL NOT START ON THIS ITEM UNTIL THE FINAL LIFT OF CLASS I HAS BEEN COMPLETED.
- THIS WORK WILL BE PAID FOR AT THE CONTRACT UNIT PRICE EACH FOR SURVEY MARKER VAULT WHICH PRICE SHALL INCLUDE ALL LABOR AND MATERIAL AS SPECIFIED INCLUDING CORING, EPOXY AND FA-01/02 AGGREGATE AND NO ADDITIONAL COMPENSATION WILL BE ALLOWED.
- THE CASTING SHALL BE ANCHORED IN THE 200 mm (8") DIAMETER CORE HOLE WITH TWO-COMPONENT EPOXY CONFORMING TO APPLICABLE PORTIONS OF ARTICLE 1025.01 (725.01) OF THE STANDARD SPECIFICATIONS.
- ALL SURVEY MARKER (VAULTS) SHALL BE PLACED 6 mm (1/4") ± BELOW THE FINAL SURFACE.
- THE 200 mm (8") DIAMETER CORE HOLE SHALL BE SUBJECT TO THE APPROVAL OF THE ENGINEER.

BILL OF MATERIAL

ALUMINUM CASTING OF THE DIMENSIONS AND SPECIFICATIONS SHOWN OR OTHER SUBJECT TO ENGINEER'S APPROVAL OF SHOP DRAWINGS, 125 mm OR 150 mm (5" OR 6") P.V.C. PIPE, SCHEDULE 40, ALUMINUM TABLET, STAMPED IN ACCORDANCE WITH STANDARD 2135. #15 X 1.2 m (3/8" X 48") RE-BAR, EPOXY AND FA-01/02 AGGREGATE.

All dimensions are in millimeters (Inches) unless otherwise shown.

REVISIONS	
NAME	DATE

CITY OF DANVILLE, ILLINOIS
WINTER AVENUE RECONSTRUCTION
IDOT DISTRICT 5
CADD DETAILS

SCALE: N/A DATE: 12/21/06
DRAWN BY: SRS CHECKED BY: MBF

F.A.I.D. DIST. NO.	SECTION	COUNTY	TOTAL SHEETS	SHEET NO.
99-00209-01-PV <td></td> <td>VERMILION</td> <td>296</td> <td>88</td>		VERMILION	296	88
STA. N/A		TO STA. N/A		
FED. ROAD DIST. NO. ILLINOIS		FED. AID PROJECT-		

CONTRACT NO.: 91358

DATE	BY	REVISION

SURVEY MARKER, TYPE 1 (SPECIAL)

TO BE USED IN FLEXIBLE PAVEMENT AND SHOULDER, A-3 BITUMINOUS TREATED SURFACE OVER AGGREGATE BASE COURSE AND TURF AREAS WITHIN THE RIGHT-OF-WAY LIMITS FOR RESETTING EXISTING CENTERLINE CONTROL POINTS AND LAND SURVEY MONUMENTS

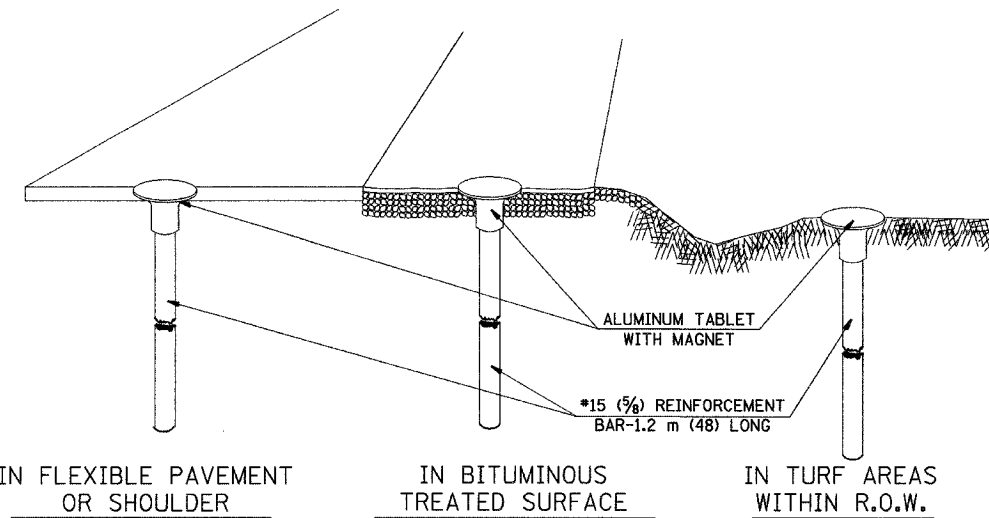

GENERAL NOTES

1. WORK ON THIS ITEM SHALL NOT START UNTIL THE FINAL SURFACE IS COMPLETED.
2. THE ALUMINUM TABLET (FORKED) SHALL REST UPON THE BOTTOM OF THE 100 mm (4") CORE HOLE. IF THE HOLE IS TOO DEEP, EPOXY GROUT MUST BE USED TO DECREASE THE DEPTH AND ALLOWED TO HARDEN BEFORE PROCEEDING.
3. THE ALUMINUM TABLET SHALL BE ANCHORED IN THE 100 mm (4") DIAMETER HOLE IN THE NEW PAVEMENT WITH TWO-COMPONENT EPOXY CONFORMING TO APPLICABLE PORTIONS OF ARTICLE 1025.01 (725.01) OF THE STANDARD SPECIFICATIONS.
4. THE 100 mm (4") CORE HOLE SHALL BE SUBJECT TO THE APPROVAL OF THE ENGINEER.
5. THE CONTRACT PRICE, EACH, FOR SURVEY MARKER, TYPE 2 (SPECIAL) SHALL BE PAYMENT IN FULL FOR FURNISHING THE ALUMINUM TABLET AND ALL LABOR AND MATERIAL TO SET THE MARKER IN PLACE, AS SPECIFIED, INCLUDING CORING THE NEW PAVEMENT.
6. ALL SURVEY MARKERS, TYPE 2 (SPECIAL) SHALL BE PLACED ± 6 mm (1/4") BELOW THE FINAL SURFACE.

SURVEY MARKER, TYPE 2 (SPECIAL)

TO BE USED IN "NEW" RIGID OR COMPOSITE PAVEMENT FOR SETTING EXISTING CENTERLINE CONTROL POINTS.

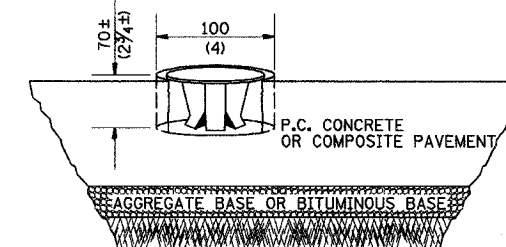

SPECIFICATIONS FOR ALUMINUM TABLET (FORKED)

ALUMINUM TABLET (FORKED) FOR USE WITH "SURVEY MARKER, TYPE 2, (SPECIAL)" SHALL BE AS SHOWN ON THE DETAIL FOR THE 83 mm (3 1/4") CONVEX SURVEY TABLET WITH ILLINOIS DEPARTMENT OF TRANSPORTATION LOGO. THIS LOGO SHALL PROVIDE FOR LETTERS RECESSED INTO THE SURFACE A MINIMUM OF 0.8 mm (1/32") FOR EASY AND LONG-TERM LEGIBILITY. THE ALUMINUM TABLET SHALL BE PRODUCED BY THE PROCESS OF ORBITAL FORGING TO PRODUCE A HIGH-STRENGTH AND DURABLE MARKER CAP WHICH WILL NOT CHIP OR BREAK AND PROVIDE A SMOOTH FINISH FOR STAMPING OF DATA IN THE FIELD. THE ALUMINUM TABLET SHALL BE DESIGNED NOT TO TURN OR ROTATE. THREE PRONGS ON A 63 mm (2 1/2") STEM SHALL BE SUCH THAT THE ALUMINUM TABLET CANNOT BE EASILY REMOVED.

COMPOSITION: ALUMINUM 92-93%; MAGNESIUM 6.5-7.5%. STRENGTH: YIELD--131-145 MPa (19,000-21,000 PSI); TENSIL--262-303 MPa (38,000-44,000 PSI); ELONGATION--10-15% (IN 50 mm (2")). SPECIFICATIONS: ALLOY 535.0; QQ-A-601ES. NO EXCEPTIONS.

SPECIFICATIONS FOR ALUMINUM TABLET

SURVEY CAP FOR REBAR. 83 mm (3 1/4") CONVEX SURVEY CAP FOR 15 mm (5/8") REBAR WITH ILLINOIS DEPARTMENT OF TRANSPORTATION LOGO. THIS LOGO SHALL PROVIDE LETTERS RECESSED INTO THE SURFACE A MINIMUM OF 0.8 mm (1/32") FOR EASY AND LONG-TERM LEGIBILITY. THE ALUMINUM CAP FOR REBAR SHALL BE PRODUCED BY THE PROCESS OF ORBITAL FORGING TO PRODUCE A HIGH-STRENGTH AND DURABLE MARKER CAP WHICH WILL NOT CHIP OR BREAK AND PROVIDE A SMOOTH FINISH FOR STAMPING OF DATA IN THE FIELD. THE ALUMINUM CAP FOR REBAR SHALL BE TAPERED FOR A PERFECT COMPRESSION FIT. A SPECIAL PLASTIC INSULATOR SHALL BE INSTALLED TO PREVENT DISSIMILAR METAL CONTACT AND CORROSION. THE PLASTIC INSULATOR SHALL FORM READILY TO THE OUTER SHAPE OF THE REBAR AND TO THE INNER SHAPE OF THE ALUMINUM CAP SOCKET. THE PLASTIC INSULATOR SHALL BE LOW DENSITY POLYETHYLENE, A MINIMUM 38 mm (1 1/2") LONG AND CONFORM TO FEDERAL SPECIFICATION L-P 390.

COMPOSITION: ALUMINUM 98.3-98.7%; OTHER 1.3-1.7%; STRENGTH: YIELD 193 MPa (28 KSI), ULTIMATE 221 MPa (32 KSI). ELONGATION 15% (IN 50 mm (2")). SPECIFICATIONS: ALUMINUM ALLOY 6101-0; ASTM B317-83 (EXCEPT TEMPER) AS FORGED. NO EXCEPTIONS.

SPECIFICATION FOR REBAR

REBAR FOR ALUMINUM TABLET. REINFORCEMENT BAR SHALL BE #15 (5/8") X 1.2 m (48") (DEFORMED).

INSPECTION OF REINFORCEMENT BAR #15 (5/8") SHALL BE DONE BY DISTRICT PERSONNEL OF THE ILLINOIS DEPARTMENT OF HIGHWAYS, DIVISION OF HIGHWAYS.

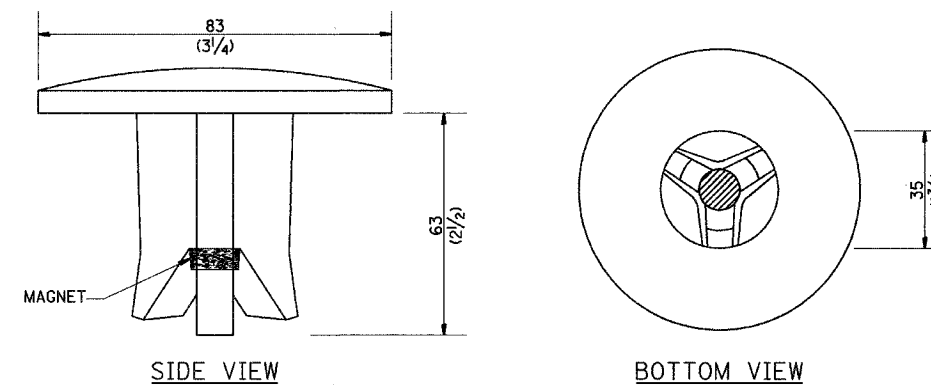

DIMENSIONS SHOWN SHALL BE EXACT. OTHERS MAY VARY, BUT SHALL BE SHOWN ON SHOP DRAWINGS.

All dimensions are in millimeters (inches) unless otherwise shown.

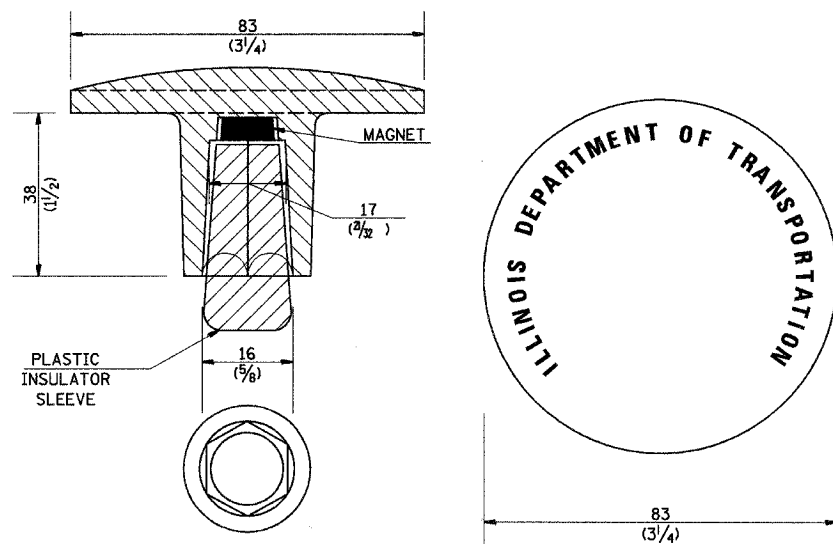

DIMENSIONS SHOWN SHALL BE EXACT. OTHERS MAY VARY, BUT SHALL BE SHOWN ON SHOP DRAWINGS.

GENERAL NOTES

1. THE CONTRACT UNIT PRICE, EACH, FOR SURVEY MARKER, TYPE 1, (SPECIAL) SHALL BE PAYMENT IN FULL FOR FURNISHING THE SURVEY MARKER.
2. ALL SURVEY MARKERS, TYPE 1 (SPECIAL) SHALL BE PLACED ± 6 mm (1/4") BELOW THE FINAL SURFACE.
3. WHEN THE TABLET AND REBAR ARE PLACED AS PART OF A SURVEY MARKER VAULT, THEY SHALL BE CONSIDERED AS INCLUDED IN THAT PAY ITEM AND THERE WILL BE NO PAYMENT FOR THE SURVEY MARKER, TYPE 1 (SPECIAL).

DESIGNED			REVISIONS		
NAME	DATE		NAME	DATE	
AWH	8/17/91		G.A.M.	11-95	
PEK	8/17/91		D.L.P.	10-96	
CADD NO.	D-1.05				

All dimensions are in millimeters (inches) unless otherwise shown.

REVISIONS	
NAME	DATE

CITY OF DANVILLE, ILLINOIS
WINTER AVENUE RECONSTRUCTION
IDOT DISTRICT 5
CADD DETAILS

SCALE: N/A
DRAWN BY: SRS
DATE: 12/21/06
CHECKED BY: MBF

DATE	
BY	
DESIGNED	
CHECKED	
IN CHARGE	
REVISIONS	
NO. OF WAYS CHECKED	
CADD FILE NAME	
PLAN	
NOTE BOOK	
NO.	

TYPICAL APPLICATIONS OF PAVEMENT MARKINGS AND MARKERS

TYPICAL PAVEMENT MARKING LEGEND

- | | | |
|----|--------------------------------------|--|
| 1 | 100 (4) SKIP-DASH (YELLOW) | |
| 2 | 100 (4) SOLID (YELLOW) | |
| 3 | 300 (12) DIAGONAL (YELLOW) | |
| 4 | 100 (4) DOUBLE YELLOW (NARROW) | |
| 5 | RESERVED | |
| 6 | RESERVED | |
| 7 | 100 (4) SKIP-DASH (WHITE) | |
| 8 | 100 (4) SOLID (WHITE) | |
| 9 | 300 (12) DIAGONAL (WHITE) | |
| 10 | 150 (6) CROSS WALK (WHITE) | |
| 11 | 600 (24) STOP BAR (WHITE) | |
| 12 | 200 (8) SOLID (WHITE) | |
| 13 | 100 (4) LANE LINE EXTENSIONS (WHITE) | |
| 14 | 100 (4) PARKING (WHITE) | |

TYPICAL PAVEMENT MARKERS LEGEND

- TWO-WAY AMBER MARKER
- ONE-WAY AMBER MARKER
- ONE-WAY CRYSTAL MARKER

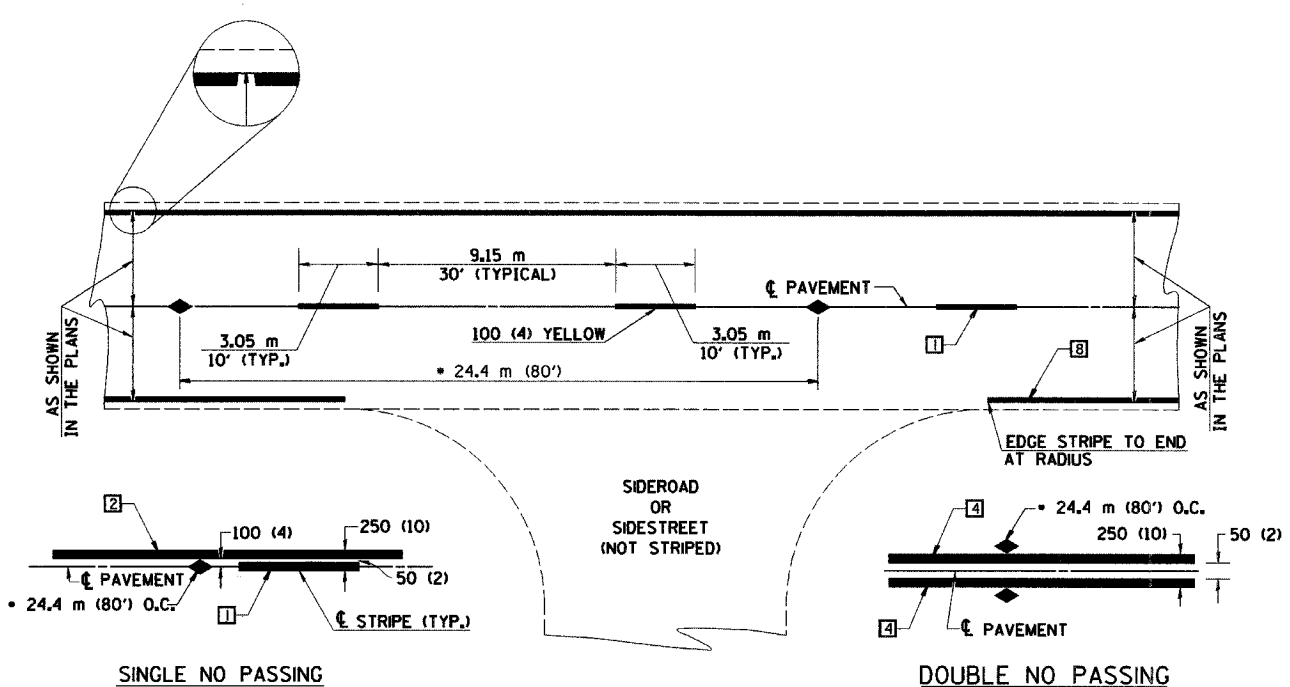

• REDUCE TO 12.2 m (40') O.C. ON CURVES WITH POSTED OR ADVISORY SPEEDS OF 70 km/h (45 mph) OR LESS.

DETAIL OF LEFT TURN LANE

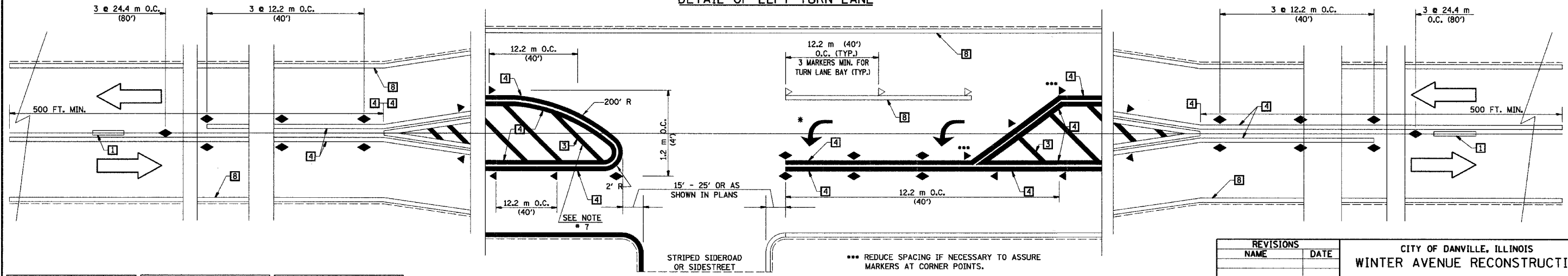

*** REDUCE SPACING IF NECESSARY TO ASSURE MARKERS AT CORNER POINTS.

• TURN ARROWS SHALL BE PLACED AS SHOWN ON SHEET #2.

ALL DIMENSIONS ARE IN MILLIMETERS (INCHES) UNLESS OTHERWISE NOTED

PLAN	DATE
SURVEYED	
DESIGNED	
CHECKED	
BY	
NO.	

DESIGNED	NAME	DATE	REVISIONS	DATE	REVISIONS	DATE
J.M.H.	J.M.H.	5-85	J.M.H.	5-3-88	D.L.P.	8-96
F.M.S.	J.M.H.	6-85	J.M.H.	10-88	D.L.P.	5-97
F-5.25					D.L.P.	4-01
					GEOMETRICS	6-01
					K.A.G.	7-02

REVISIONS	NAME	DATE

CITY OF DANVILLE, ILLINOIS
WINTER AVENUE RECONSTRUCTION
 IDOT DISTRICT 5
 CADD DETAILS

SCALE: N/A
 DRAWN BY: SRS
 DATE: 12/21/06
 CHECKED BY: MBF

TYPICAL APPLICATIONS OF PAVEMENT MARKINGS AND MARKERS

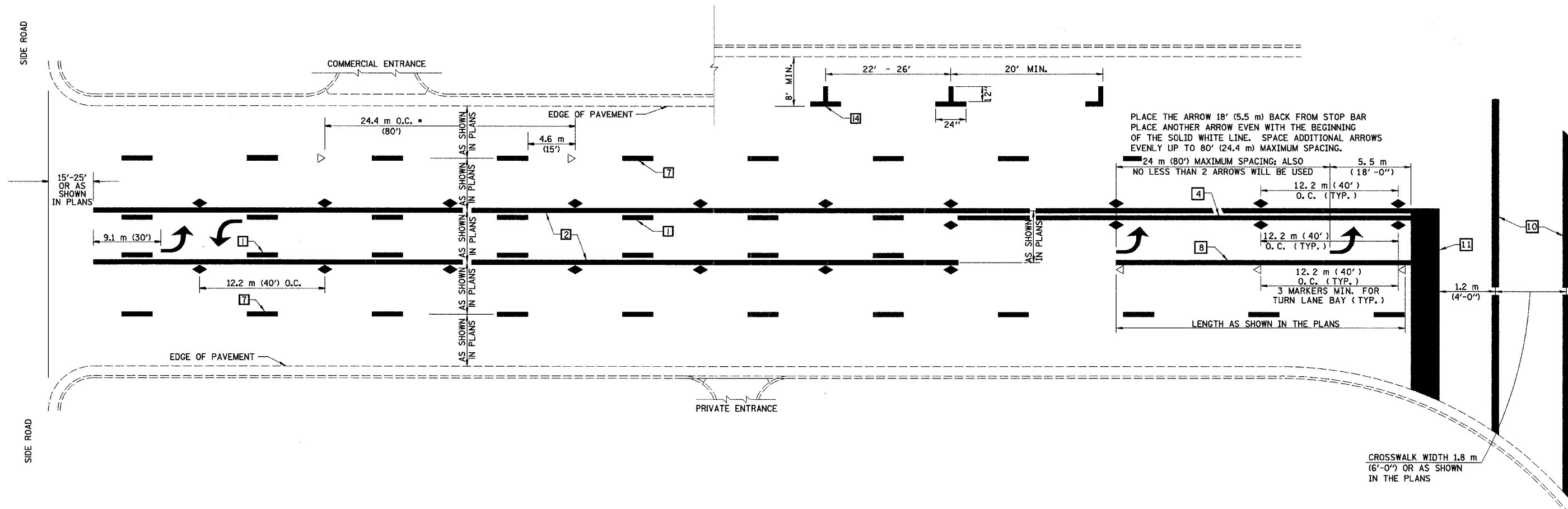

PLACE THE ARROW 18' (5.5 m) BACK FROM STOP BAR
 PLACE ANOTHER ARROW EVEN WITH THE BEGINNING
 OF THE SOLID WHITE LINE. SPACE ADDITIONAL ARROWS
 EVENLY UP TO 80' (24.4 m) MAXIMUM SPACING.

24 m (80') MAXIMUM SPACING; ALSO
 NO LESS THAN 2 ARROWS WILL BE USED
 5.5 m (18'-0")
 12.2 m (40') O.C. (TYP.)
 12.2 m (40') O.C. (TYP.)
 12.2 m (40') O.C. (TYP.)
 3 MARKERS MIN. FOR TURN LANE BAY (TYP.)
 LENGTH AS SHOWN IN THE PLANS

CROSSWALK WIDTH 1.8 m (6'-0") OR AS SHOWN IN THE PLANS

SPECIAL NOTES:
 TURN ARROW PAIRS SHALL BE PLACED AT 75 m (250') INTERVALS AND SHALL BE EVENLY SPACED BETWEEN BOTH ENDS OF THE BIDIRECTIONAL LEFT TURN LANE.
 THE SOLID YELLOW PAVEMENT MARKINGS [2] SHOULD GENERALLY START OR END NEAR THE RADIUS POINT OF EACH STREET RETURN EXCEPT WHERE ONE OR BOTH ENDS WOULD INCLUDE STOP BARS.
 THE SKIP-DASH PAVEMENT MARKINGS [1] OR [7] SHOULD BE CENTERED BETWEEN BOTH ENDS OF EACH CITY BLOCK AND SHALL BE PLACED SO THEY LINE UP ACROSS FROM EACH OTHER. SEE EXAMPLE ABOVE.
 * REDUCE TO 12.2 METERS (40 FEET) O.C. ON CURVES WHERE ADVISORY SPEEDS ARE 15 kph (10 MPH) LOWER THAN POSTED SPEEDS.
 ** WHERE DOUBLE LANE LINE MARKERS ARE SPECIFIED, THEY SHALL BE SPACED AS SHOWN ABOVE.

All dimensions are in millimeters (Inches) unless otherwise shown.

DESIGNED	J.M.H.	6/88
CHECKED	C.T.D.	6/88
CADD NO.	F-5.25	

REVISIONS	
NAME	DATE
G.A.M.	11/95
CHECKED D.L.P.	12/95

REVISIONS	
NAME	DATE
D.L.P.	8/97
GEOMETRICS	6/01

REVISIONS	
NAME	DATE

CITY OF DANVILLE, ILLINOIS
 WINTER AVENUE RECONSTRUCTION
 IDOT DISTRICT 5
 CADD DETAILS

SCALE: N/A
 DRAWN BY: SRS
 DATE: 12/21/06
 CHECKED BY: MBF

PLAN	SURVEYED	DATE
NOTE BOOK	PLANNED	BY
NO.	FILED	
	BY	
	DATE	
	FILED	
	BY	
	DATE	

TYPICAL APPLICATIONS OF PAVEMENT MARKINGS AND MARKERS

F.A.D.D. RTE.	SECTION	COUNTY	TOTAL SHEETS	SHEET NO.
6998	99-00209-01-PV	VERMILION	296	92
STA. N/A	TO STA. N/A			
FED. ROAD DIST. NO. ILLINOIS	FED. AID PROJECT-			
CONTRACT NO.: 91358				

PLAN	SURVEYED	DATE
	BY	
	PLOTTED	
	CHECKED	
	NO. OF MAY CHECKED	
	CADD FILE NAME	
	NO.	

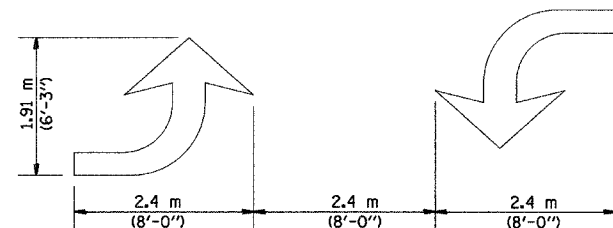

TYPICAL DOUBLE TURN ARROWS (WHITE)

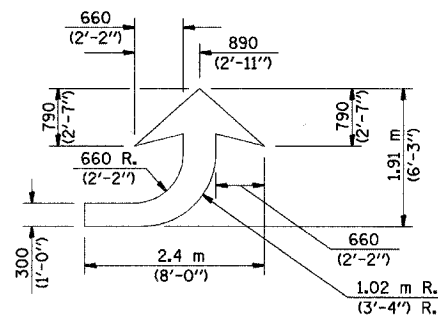

LEFT ARROW
REVERSE FOR RIGHT ARROW
AREA= 1.47 m² (15.6 SQ. FT.)
(WHITE)

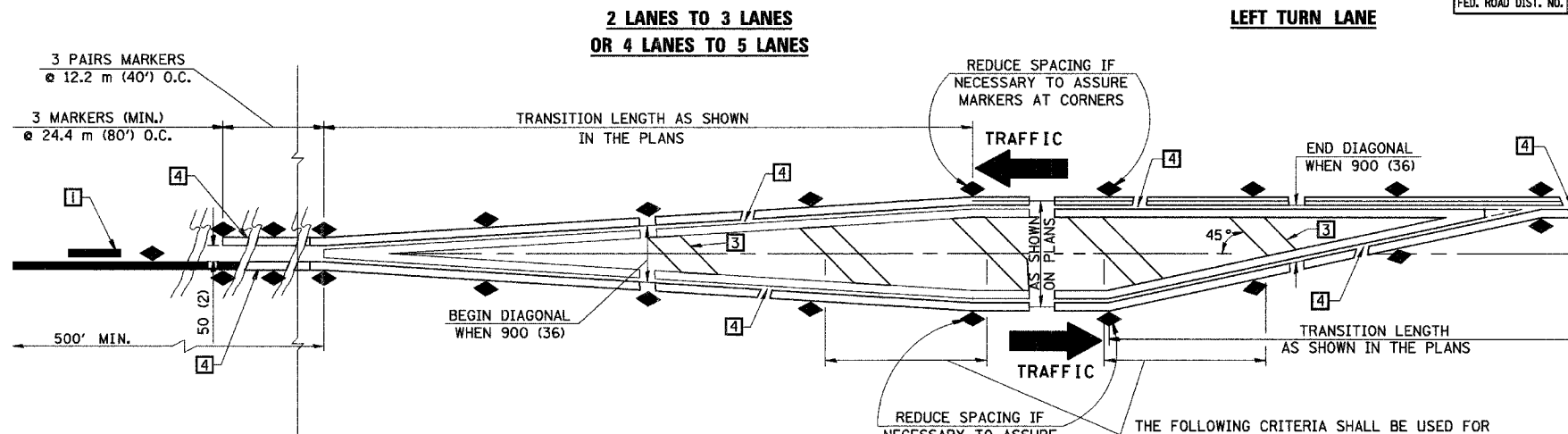

SPECIAL NOTE:
THE ACTUAL MEDIAN CONFIGURATION WILL BE AS SHOWN IN THE PLANS (TAPER OR REVERSE CURVE).

THE FOLLOWING CRITERIA SHALL BE USED FOR SELECTING THE DIAGONAL PAVEMENT MARKING SPACING:
< 50 kph USE 4.5 m (< 30 MPH USE 15')
50-75 kph USE 6.0 m (30-45 MPH USE 20')
> 75 kph USE 9.0 m (> 45 MPH USE 30')

TYPICAL MEDIAN TRANSITIONS

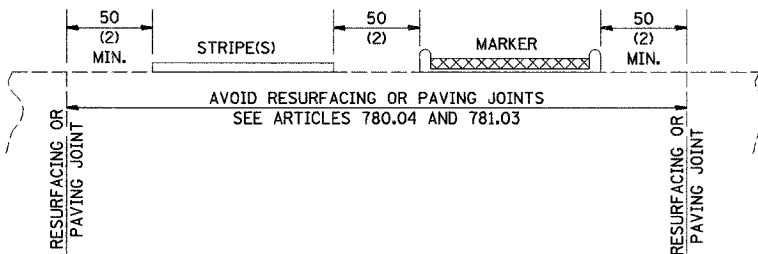

RELATIONSHIP OF STRIPES, MARKERS AND JOINTS

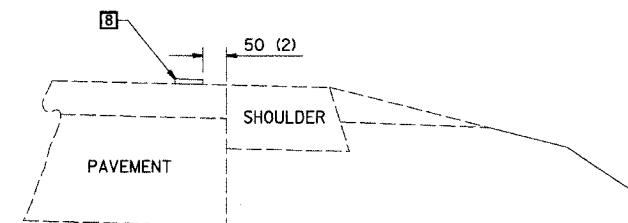

RELATIONSHIP OF EDGE STRIPE TO SAFETY SHOULDER OR PAVED SURFACE

GENERAL NOTES

- WHEN MEDIANS ARE PRESENT PAVEMENT MARKINGS ARE TO BE PLACED ADJACENT TO MEDIANS.
- SCALE: NONE
- SOME OF THE INFORMATION INCLUDED WITH THIS DETAIL MAY NOT BE APPLICABLE TO THIS IMPROVEMENT.
- PAVEMENT MARKINGS ARE TO BE EXTENDED THROUGH OMISSIONS WHEN APPLICABLE.
- A STRIPING KEY IS AVAILABLE ELSEWHERE AND SHALL BE SHOWN WHERE THE QUANTITIES ARE LISTED.
- FINAL PAVEMENT MARKINGS SHALL BE IN PLACE PRIOR TO PLACING ANY RAISED REFLECTIVE PAVEMENT MARKERS.
- THE FOLLOWING CRITERIA SHALL BE USED FOR SELECTING THE DIAGONAL PAVEMENT MARKING SPACING,
< 50 kph USE 4.5 m (< 30 MPH USE 15')
50-75 kph USE 6.0 m (30-45 MPH USE 20')
> 75 kph USE 9.0 m (> 45 MPH USE 30')

All dimensions are in millimeters (inches) unless otherwise shown.

NAME	DATE
DESIGNED J.M.H.	6/88
CHECKED C.T.D.	6/88
CADD NO. F-5.25	

REVISIONS	
NAME	DATE
G.A.M.	11/95
CHECKED D.L.P.	12/95

REVISIONS	
NAME	DATE
D.L.P.	8/97
GEOMETRICS	6/01

REVISIONS	
NAME	DATE

CITY OF DANVILLE, ILLINOIS
WINTER AVENUE RECONSTRUCTION
IDOT DISTRICT 5
CADD DETAILS

SCALE: N/A
DRAWN BY: SRS
DATE: 12/21/06
CHECKED BY: MBF

F.A.U. RTE.	SECTION	COUNTY	TOTAL SHEETS	SHEET NO.
6998	99-00209-01-PV	VERMILION	296	93
STA.	TO STA.		FED. AID PROJECT-	
FED. ROAD DIST. NO.	ILLINOIS	FED. AID PROJECT-		
CONTRACT NO.: 91358				

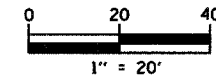

VIDEO DETECTION ZONE - PRESENCE

APPROACH	LANE	LENGTH OF DETECTION
NORTH	LT - THRU	45 FT
SOUTH	LT - THRU	45 FT
EAST	LT - THRU	45 FT
WEST	LT - THRU	45 FT

VIDEO DETECTION ZONE - ADVANCED

APPROACH	LANE	ZONE LOCATION*			
NORTH	THRU	240 FT			
SOUTH	THRU	240 FT			
EAST	THRU	240 FT </tr <tr> <td>WEST</td> <td>THRU</td> <td>240 FT</td> </tr>	WEST	THRU	240 FT
WEST	THRU	240 FT			

* DISTANCE FROM STOP BAR

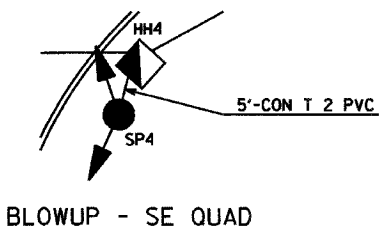
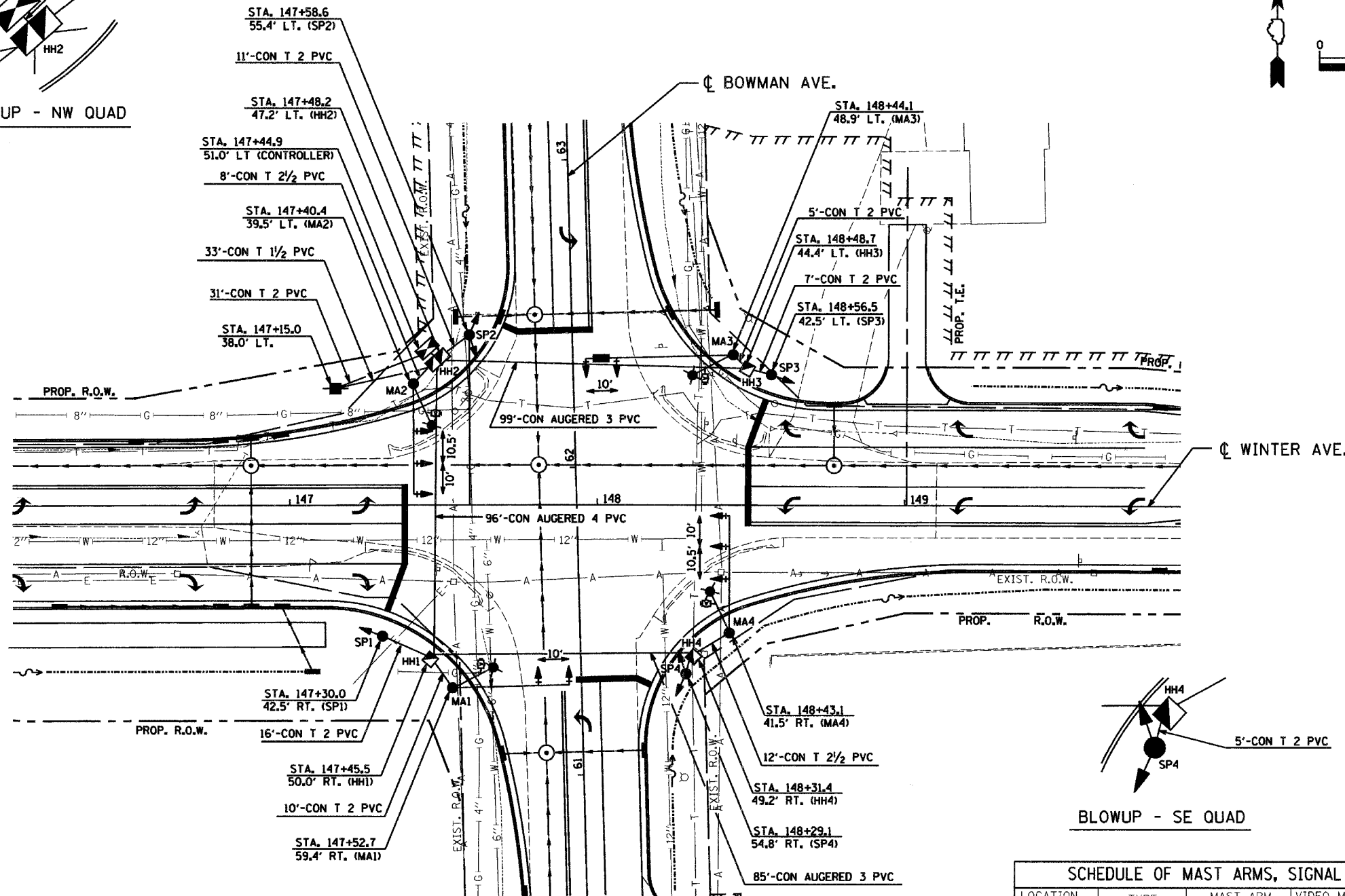
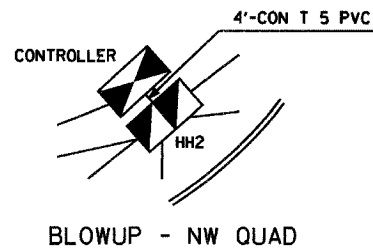

LEGEND

- PROPOSED CONTROLLER AND CABINET
- PROPOSED SIGNAL HEAD AND POST
- PROPOSED COMBINATION MAST ARM ASSEMBLY W/ LUMINAIRE, SIGNAL HEAD, BACKPLATE
- PROPOSED VIDEO DETECTOR
- PROPOSED HANDHOLE
- PROPOSED DOUBLE HANDHOLE
- PROPOSED SERVICE INSTALLATION
- PROPOSED MAST ARM DAMPENING DEVICE

SCHEDULE OF MAST ARMS, SIGNAL POSTS AND BASES

LOCATION	TYPE	MAST ARM LENGTH, FT	VIDEO MOUNTING HEIGHT, FT	TYPE A 24 IN	TYPE D	TYPE E 36 IN
MA1	STEEL	38.0	41.0	-	-	11.0 FT
SP1	ALUMINUM	-	-	3.0 FT	-	-
MA2	STEEL	36.0	41.0	-	-	11.0 FT
SP2	ALUMINUM	-	-	3.0 FT	-	-
MA3	STEEL	48.0	41.0	-	-	13.0 FT
SP3	ALUMINUM	-	-	3.0 FT	-	-
MA4	STEEL	38.0	41.0	-	-	11.0 FT
SP4	ALUMINUM	-	-	3.0 FT	-	-
CONTROLLER	-	-	-	-	3.0 FT	-

REVISIONS	
NAME	DATE

CITY OF DANVILLE, ILLINOIS
WINTER AVENUE RECONSTRUCTION
PROPOSED TRAFFIC SIGNAL
SIGNAL LAYOUT
BOWMAN AVENUE & WINTER AVENUE
SHEET 1 OF 3

SCALE: 1" = 20'
 DATE: 12/21/06
 DRAWN BY: SRS
 CHECKED BY: MBF

DATE	
BY	
PLAN	
SURVEYED	
PLOTTED	
CHECKED	
DATE	
NO. OF PAGES	
FILE NAME	
NO.	

F.A.U. RTE.	SECTION	COUNTY	TOTAL SHEETS	SHEET NO.
6998	99-00209-01-PV	VERMILION	296	96
STA. 97+00		TO STA. 109+00		
FED. ROAD DIST. NO. ILLINOIS		FED. AID PROJECT-		

CONTRACT NO.: 91358

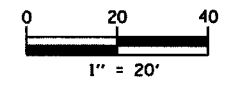
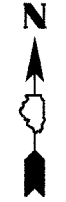

ALL PAVEMENT MARKINGS ARE THERMOPLASTIC UNLESS OTHERWISE NOTED

BEGIN IMPROVEMENT
BEGIN PERMANENT STRIPING
STA. 100+10.00

PLAN	DATE
SURVEYED	BY
DESIGNED	BY
CHECKED	BY
IN CHARGE	BY
NOTE BOOK NO.	
CARD FILE NAME	

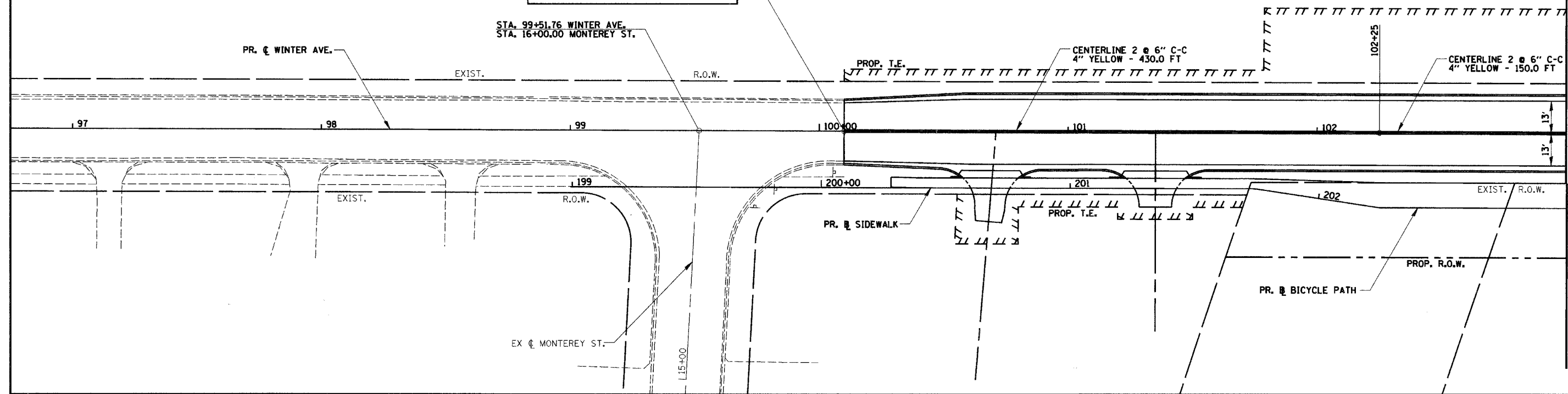

MATCHLINE 103+00
(WINTER AVENUE)

MATCHLINE 203+00
(BICYCLE PATH)

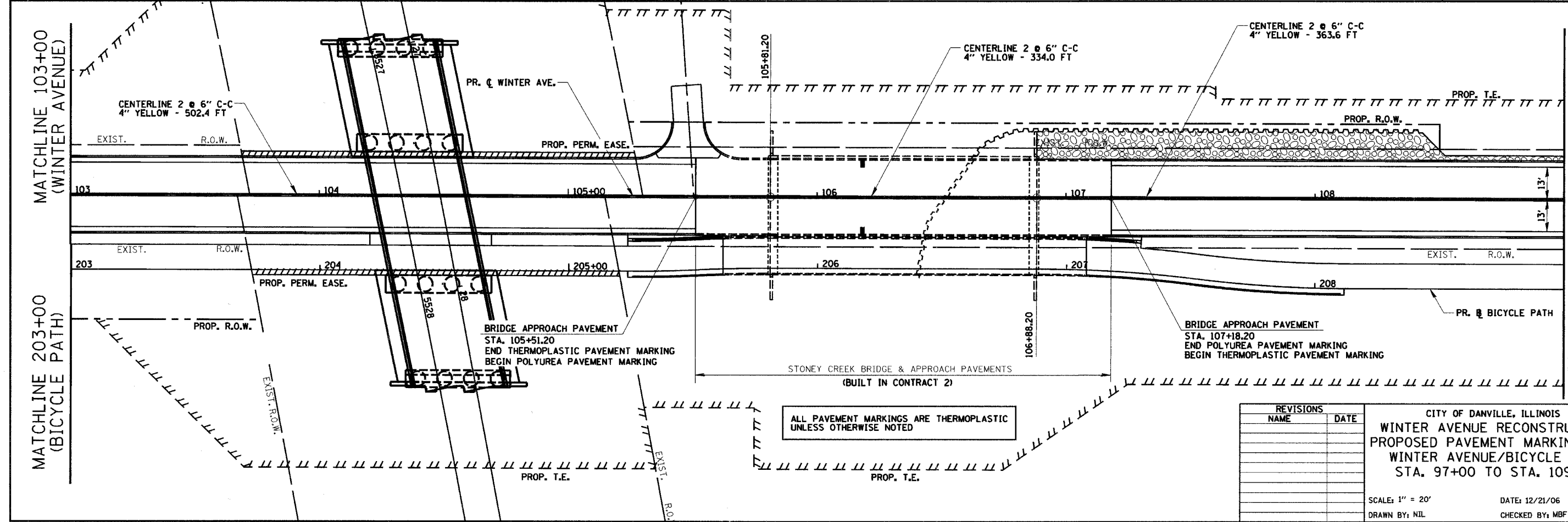

MATCHLINE 103+00
(WINTER AVENUE)

MATCHLINE 203+00
(BICYCLE PATH)

MATCHLINE 109+00
(WINTER AVENUE)

MATCHLINE 209+00
(BICYCLE PATH)

ALL PAVEMENT MARKINGS ARE THERMOPLASTIC UNLESS OTHERWISE NOTED

REVISIONS	
NAME	DATE

CITY OF DANVILLE, ILLINOIS
WINTER AVENUE RECONSTRUCTION
PROPOSED PAVEMENT MARKING PLAN
WINTER AVENUE/BICYCLE PATH
STA. 97+00 TO STA. 109+00

SCALE: 1" = 20'
DRAWN BY: NIL
DATE: 12/21/06
CHECKED BY: MBF

ALL PAVEMENT MARKINGS ARE THERMOPLASTIC UNLESS OTHERWISE NOTED

F.A.I.D. NO.	SECTION	COUNTY	TOTAL SHEETS	SHEET NO.
6998	99-00209-01-PV	VERMILION	296	97
STA. 109+00		TO STA. 121+00		
FED. ROAD DIST. NO. ILLINOIS		FED. AID PROJECT-		
CONTRACT NO.: 91358				

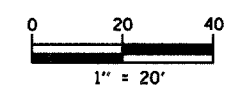

PLAN	DATE
REVISIONS	BY
NO.	
1	
2	
3	
4	
5	
6	
7	
8	
9	
10	

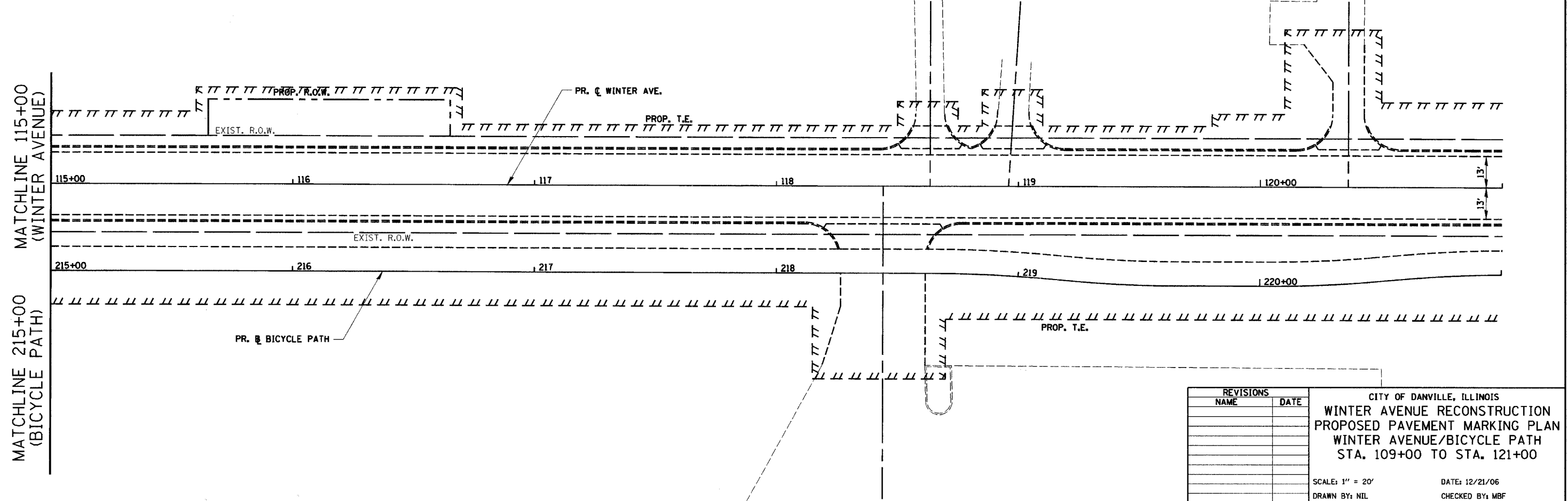
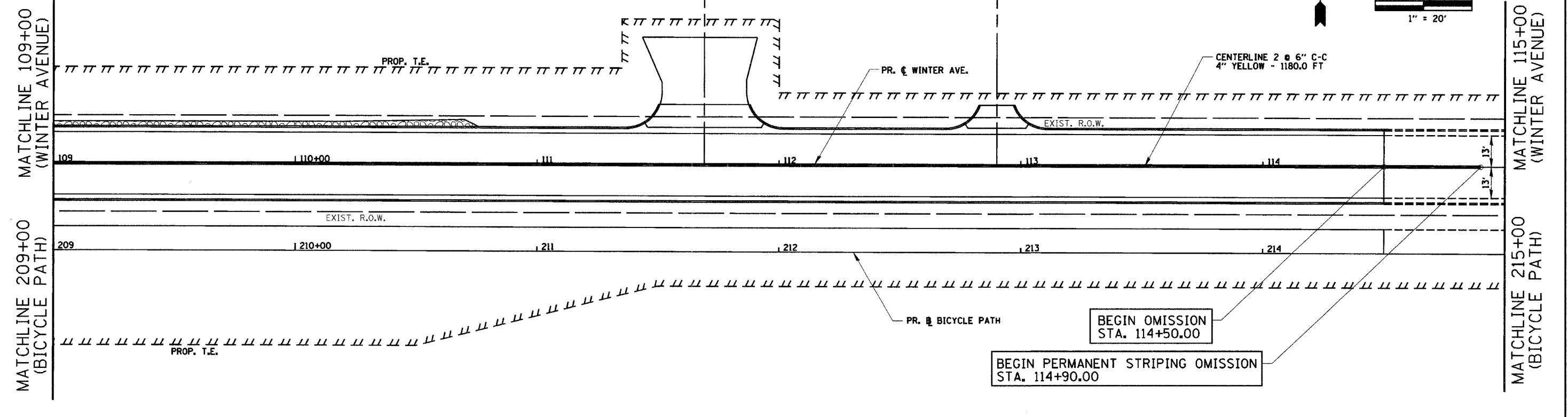

REVISIONS	
NAME	DATE

CITY OF DANVILLE, ILLINOIS
WINTER AVENUE RECONSTRUCTION
PROPOSED PAVEMENT MARKING PLAN
WINTER AVENUE/BICYCLE PATH
STA. 109+00 TO STA. 121+00

SCALE: 1" = 20'
 DRAWN BY: NIL

DATE: 12/21/06
 CHECKED BY: MBF

PLAN	DATE
SURVEYED	
DESIGNED	
CHECKED	
BY	
NO.	
DATE	
BY	
NO.	
DATE	
BY	
NO.	
DATE	

F.A.I. RTE.	SECTION	COUNTY	TOTAL SHEETS	SHEET NO.
6998	99-00209-01-PV	VERMILION	296	98
STA. 133+00	TO STA. 145+00			
FED. ROAD DIST. NO. ILLINOIS	FED. AID PROJECT-		CONTRACT NO.: 91358	

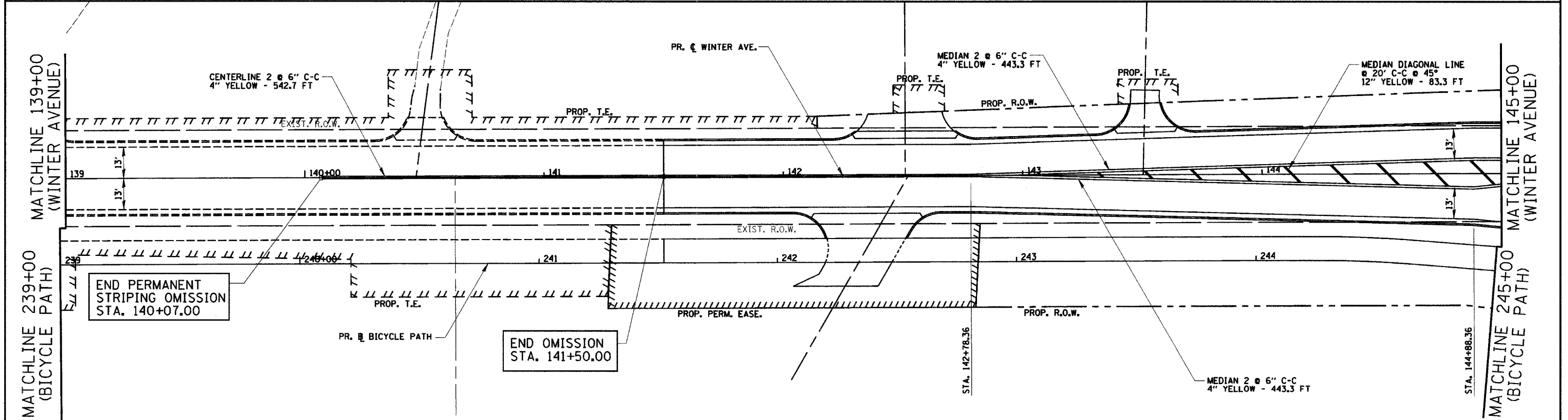
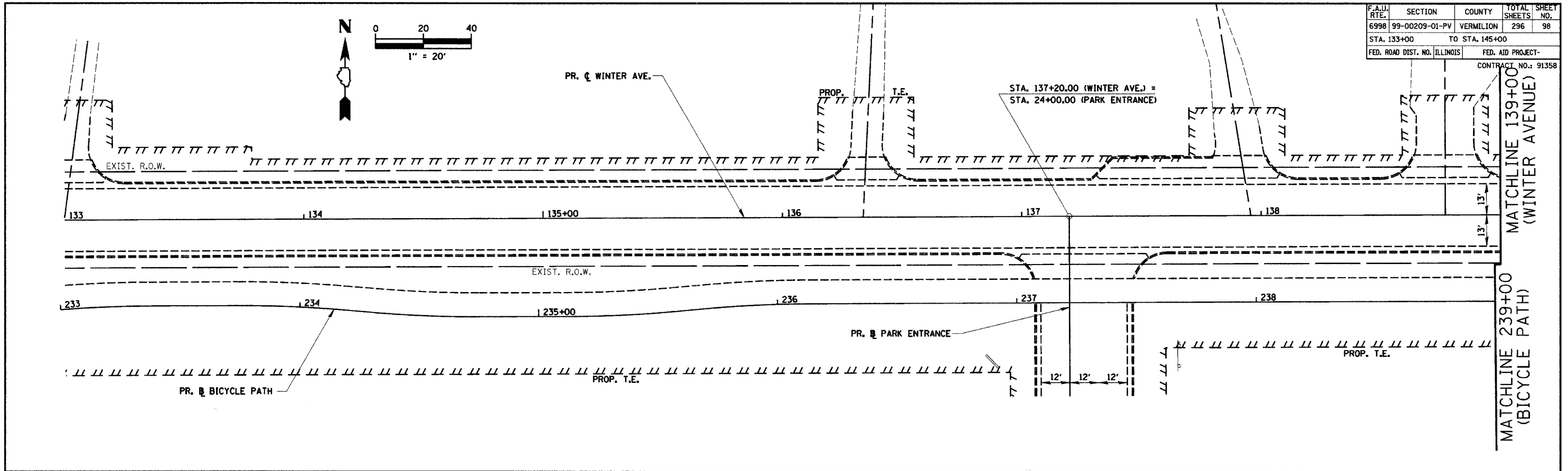

ALL PAVEMENT MARKINGS ARE THERMOPLASTIC UNLESS OTHERWISE NOTED

REVISIONS	
NAME	DATE

CITY OF DANVILLE, ILLINOIS
**WINTER AVENUE RECONSTRUCTION
 PROPOSED PAVEMENT MARKING PLAN
 WINTER AVENUE/BICYCLE PATH
 STA. 133+00 TO STA. 145+00**

SCALE: 1" = 20' DATE: 12/21/06
 DRAWN BY: NIL CHECKED BY: MBF

DATE	
BY	
PLAN	
SURVEYED	
DESIGNED	
CHECKED	
REVISIONS	
NO.	

F.A.U. RTE.	SECTION	COUNTY	TOTAL SHEETS	SHEET NO.
6998	99-00209-01-PV	VERMILION	296	99
STA. #	TO STA. #			
FED. ROAD DIST. NO. ILLINOIS	FED. AID PROJECT-			
CONTRACT NO.: 91358				

*WINTER AVENUE STA. 145+00 TO 151+00
BOWMAN AVENUE STA. 60+00 TO 63+50

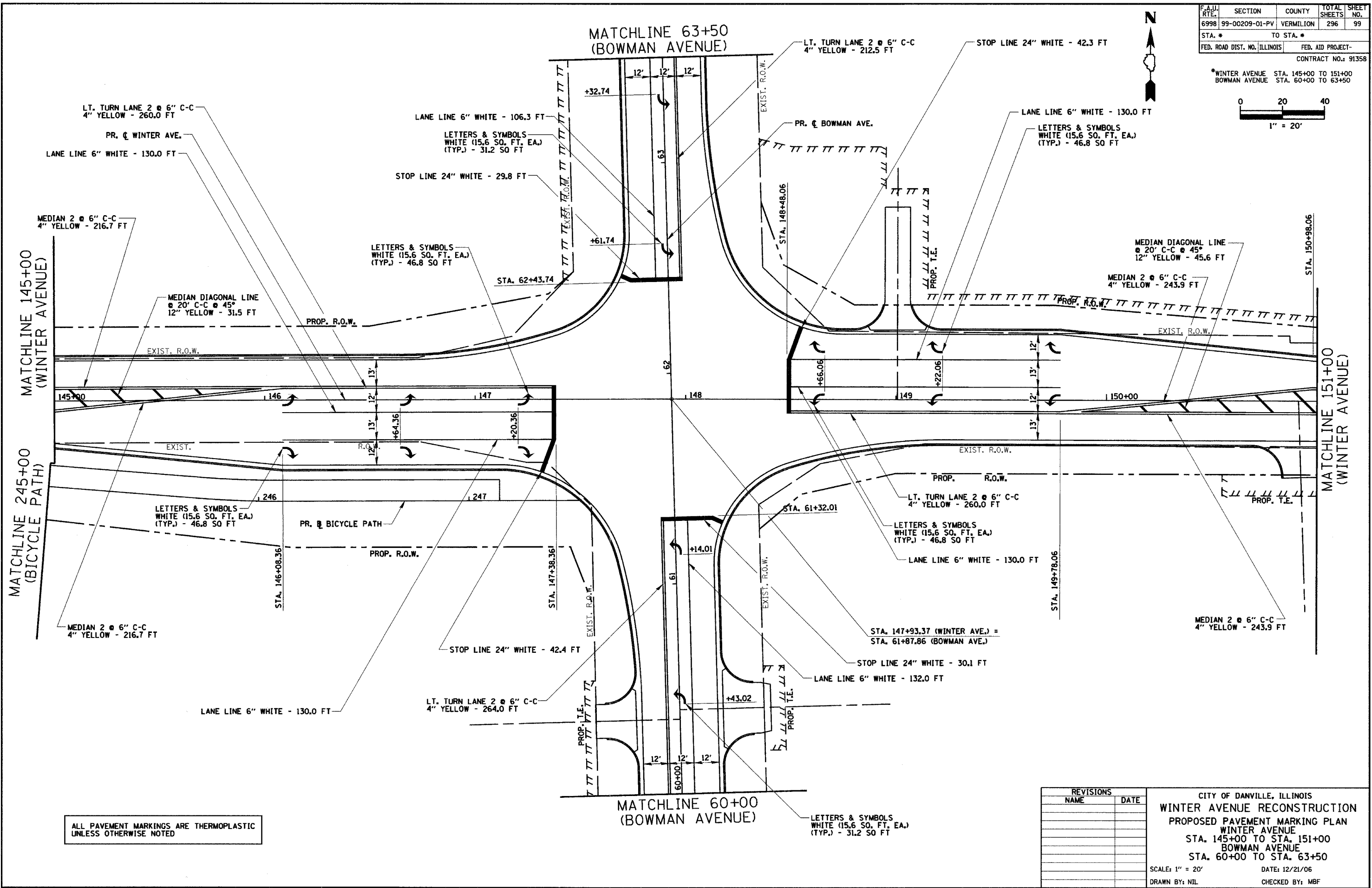
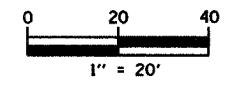

ALL PAVEMENT MARKINGS ARE THERMOPLASTIC UNLESS OTHERWISE NOTED

REVISIONS	
NAME	DATE

CITY OF DANVILLE, ILLINOIS
WINTER AVENUE RECONSTRUCTION
 PROPOSED PAVEMENT MARKING PLAN
 WINTER AVENUE
 STA. 145+00 TO STA. 151+00
 BOWMAN AVENUE
 STA. 60+00 TO STA. 63+50
 SCALE: 1" = 20'
 DATE: 12/21/06
 DRAWN BY: NIL
 CHECKED BY: MBF

PLAN	DATE
BY	
CHECKED	
DATE	
NO.	

F.A.I.D. RTE.	SECTION	COUNTY	TOTAL SHEETS	SHEET NO.
6998	99-00209-01-PV	VERMILION	296	100
STA. 151+00	TO STA. 157+00			
FED. ROAD DIST. NO. ILLINOIS	FED. AID PROJECT-			
CONTRACT NO.: 91358				

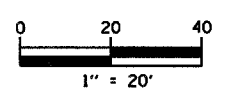

END IMPROVEMENT
END PERMANENT STRIPING
STA. 156+35.00

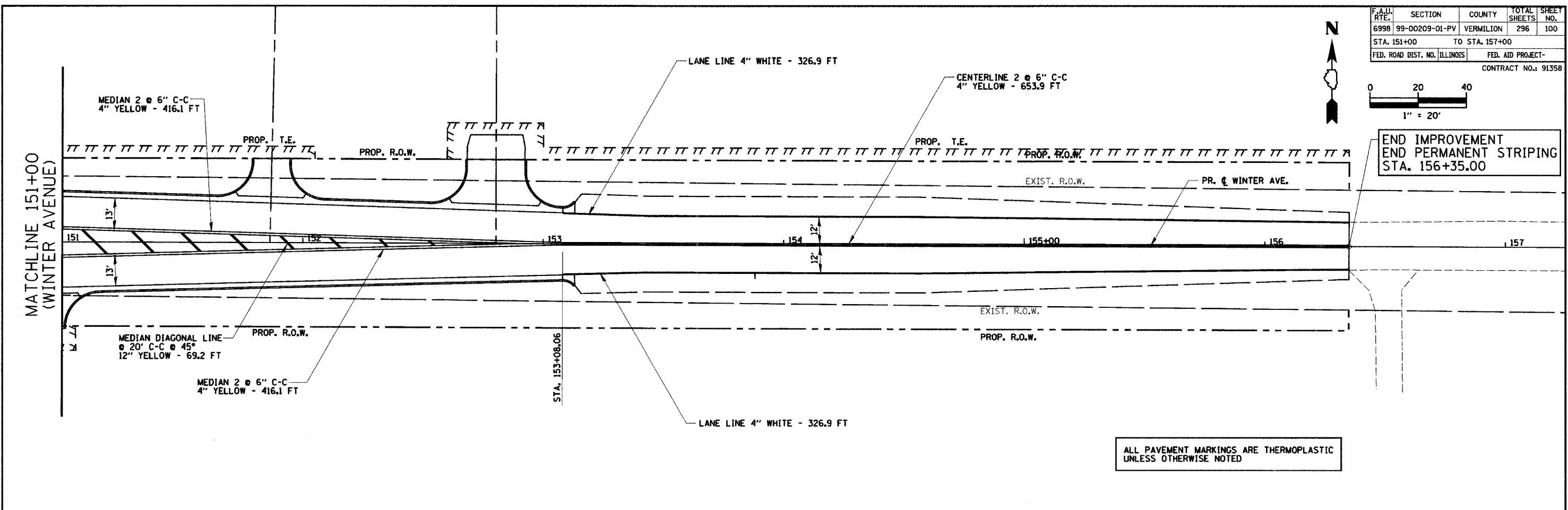

ALL PAVEMENT MARKINGS ARE THERMOPLASTIC
UNLESS OTHERWISE NOTED

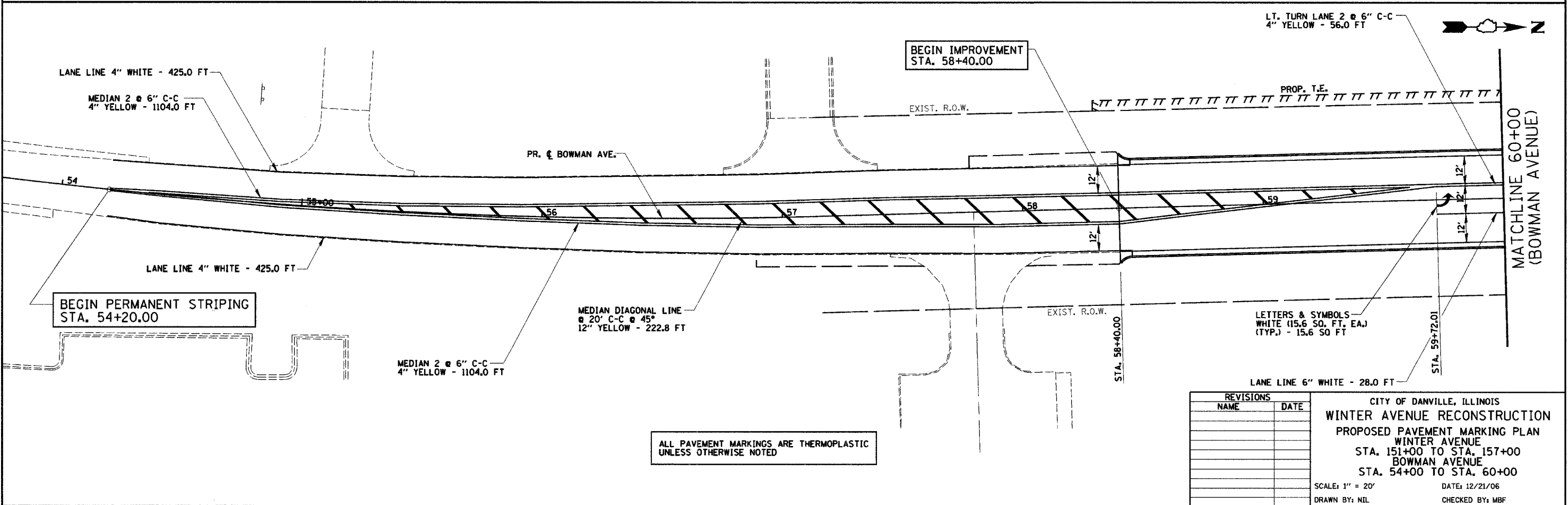

ALL PAVEMENT MARKINGS ARE THERMOPLASTIC
UNLESS OTHERWISE NOTED

REVISIONS	
NAME	DATE

CITY OF DANVILLE, ILLINOIS
WINTER AVENUE RECONSTRUCTION
PROPOSED PAVEMENT MARKING PLAN
WINTER AVENUE
STA. 151+00 TO STA. 157+00
BOWMAN AVENUE
STA. 54+00 TO STA. 60+00
SCALE: 1" = 20'
DATE: 12/21/06
DRAWN BY: NIL
CHECKED BY: MBF