

F.A.C. DIST.	SECTION	COUNTY	TOTAL SHEETS	SHEET NO.
6385	96-00306-00-SP	McLean	30	2
STA.		TO STA.		
FED. ROAD DIST. NO.		LLHRS	FED. RD PROJECT	

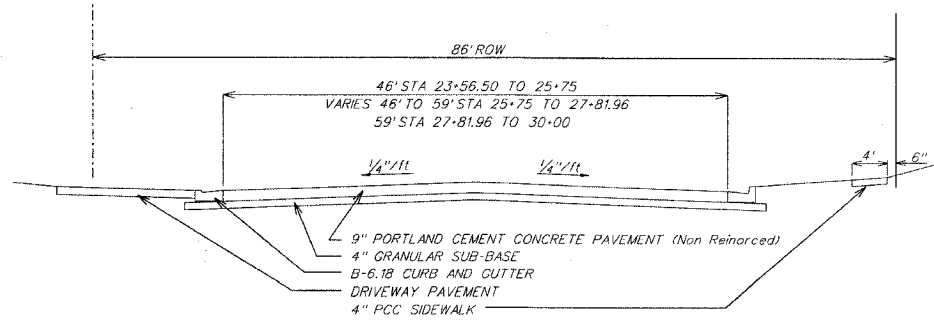

Martin Luther King Jr. Drive  
Existing Typical Section  
STA 23+56.50 TO STA 30+00  
(NO SCALE)

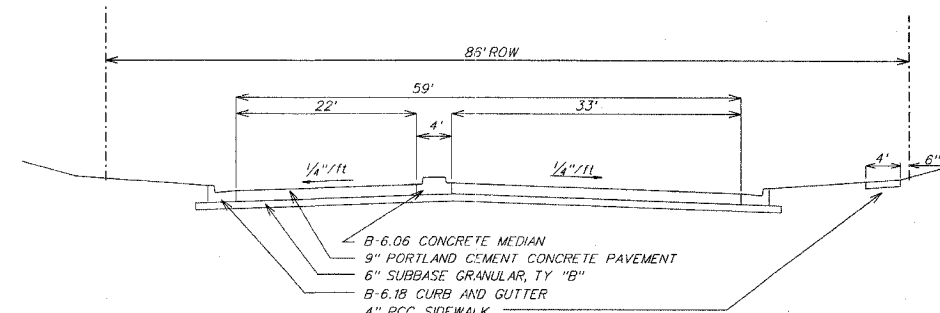

Martin Luther King Jr. Drive  
Existing Typical Section  
STA 30+00 TO STA 31+04  
(NO SCALE)

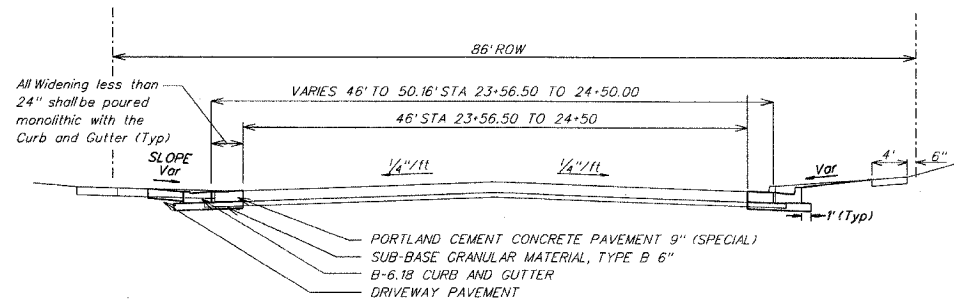

Martin Luther King Jr. Drive  
Proposed Typical Section  
STA 23+56.50 TO STA 24+50.00  
(NO SCALE)

TIE PROPOSED PAVEMENT TO EXISTING PAVEMENT WITH 30" LONG #4 BARS DRILLED AND GROUTED INTO THE EXISTING PVT

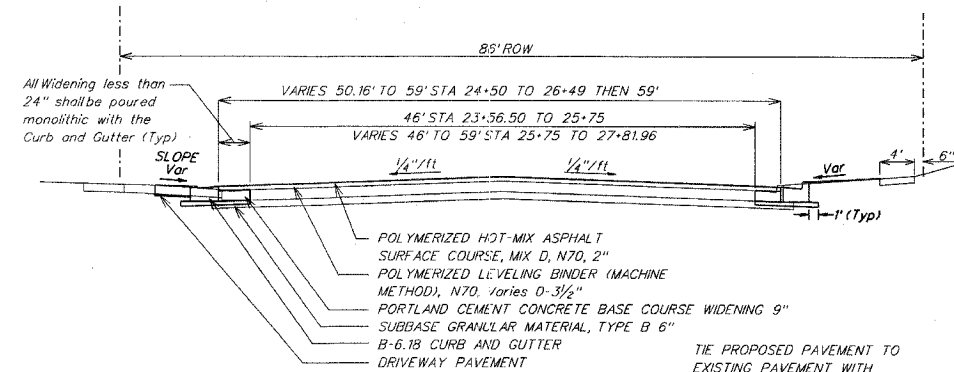

Martin Luther King Jr. Drive  
Proposed Typical Section  
STA 24+50.00 TO STA 28+78.41  
(NO SCALE)

TIE PROPOSED PAVEMENT TO EXISTING PAVEMENT WITH 30" LONG #4 BARS DRILLED AND GROUTED INTO THE EXISTING PVT

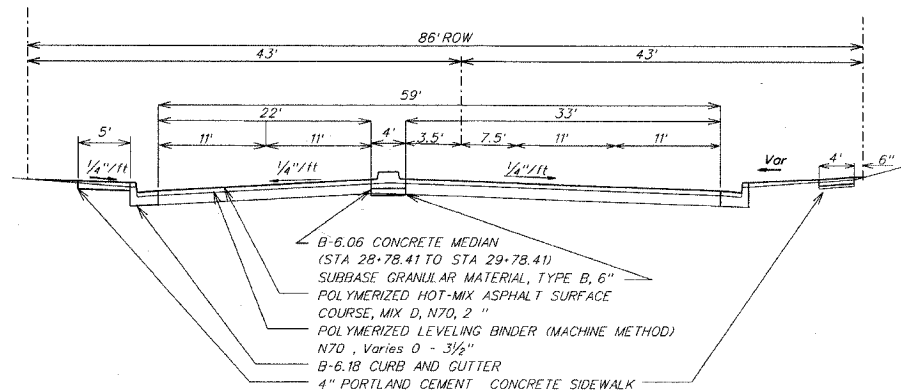

Martin Luther King Jr. Drive  
Proposed Typical Section  
STA 28+78.41 TO STA 30+00  
(NO SCALE)

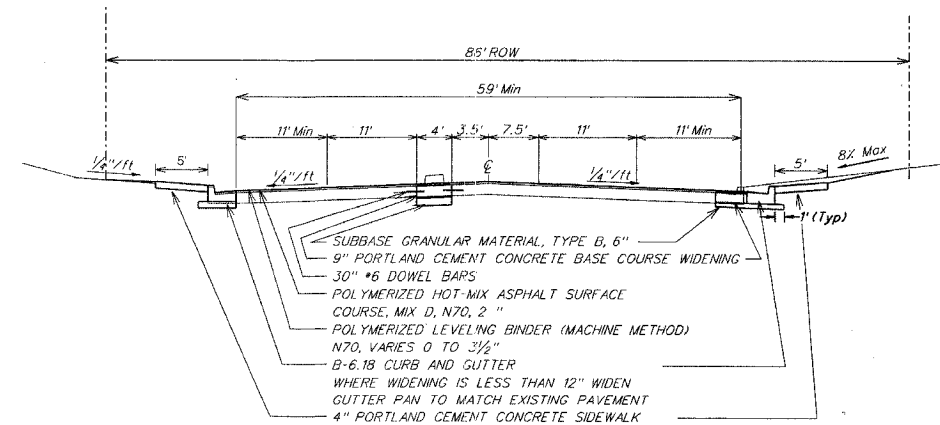

Martin Luther King Jr. Drive  
Proposed Typical Section  
STA 30+00 TO STA 31+04  
(NO SCALE)

TIE PROPOSED PAVEMENT TO THE EXISTING PAVEMENT WITH 30" LONG #6 BARS AT 24" CENTERS DRILLED AND GROUTED INTO THE EXISTING PAVEMENT