

HA023

MARKING SCHEDULE

| DESCRIPTION | UNIT AREA | NO. REQ'D | TOTAL |
|-----------------------------|-----------|-----------|--------|
| HOLD LINE RUNWAY 6 | 936 | 1 | 936 |
| HOLD LINE RUNWAY 24 | 360 | 1 | 360 |
| HOLD LINE TAXIWAY | 360 | 1 | 360 |
| TOTAL BLACK | | | 1,656 |
| NUMERAL 6 | 712 | 1 | 712 |
| NUMERAL 2 | 652 | 1 | 652 |
| NUMERAL 4 | 602 | 2 | 1,204 |
| NUMERAL 1 | 320 | 1 | 320 |
| CENTERLINE STRIPE 145' x 3' | 435 | 2 | 870 |
| CENTERLINE STRIPE 141' x 3' | 423 | 1 | 423 |
| CENTERLINE STRIPE 120' x 3' | 360 | 19 | 6,840 |
| 15.00' x 150' STRIPE | 2,250 | 4 | 9,000 |
| 5.75' x 150' STRIPE | 863 | 12 | 10,356 |
| TOTAL WHITE | | | 30,377 |
| HOLD LINE RUNWAY 6 | 354 | 1 | 354 |
| HOLD LINE RUNWAY 24 | 135 | 1 | 135 |
| HOLD LINE TAXIWAY | 135 | 1 | 135 |
| TAXIWAY CENTERLINE | 768 | 1 | 768 |
| 24 TAXIWAY CENTERLINE | 915 | 1 | 915 |
| TOTAL YELLOW | | | 2,307 |
| TOTAL MARKING | | | 34,340 |

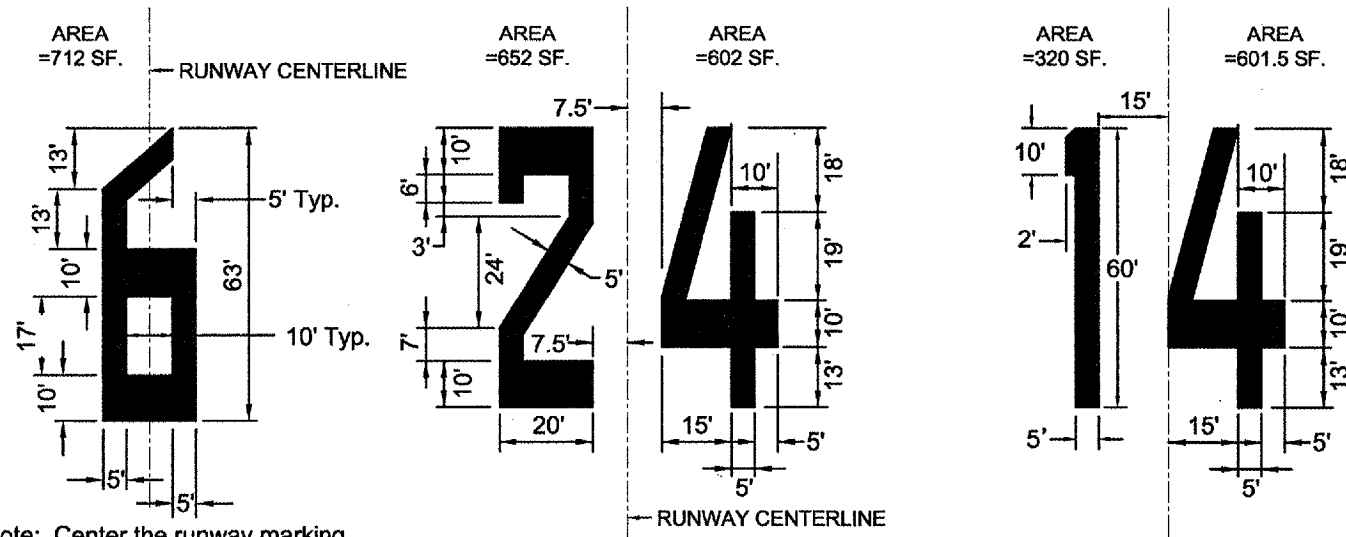

RUNWAY DESIGNATION MARKING DETAILS

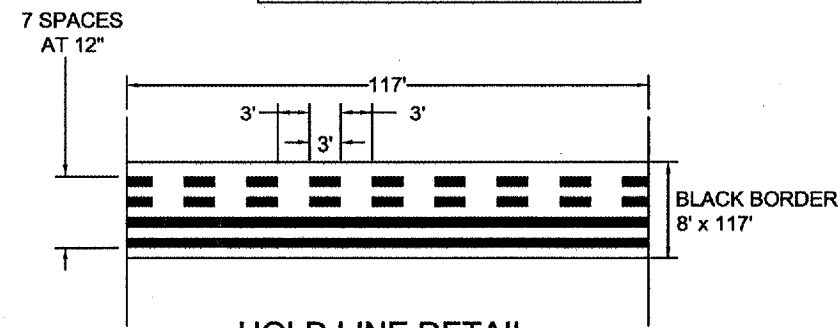

**HOLD LINE DETAIL
 RUNWAY 6 TURNAROUND**

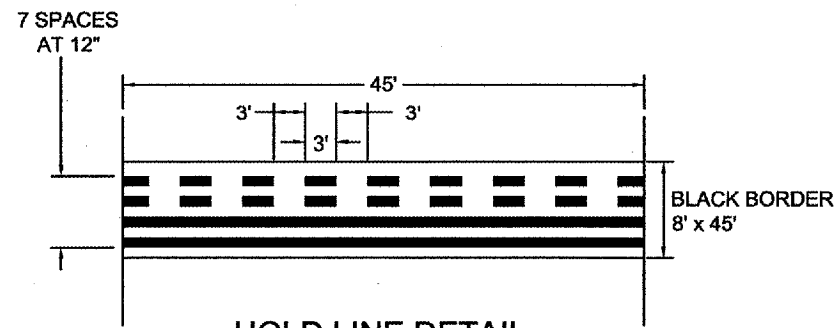

**HOLD LINE DETAIL
 RUNWAY 24 TURNAROUND
 TAXIWAY TURNAROUND**

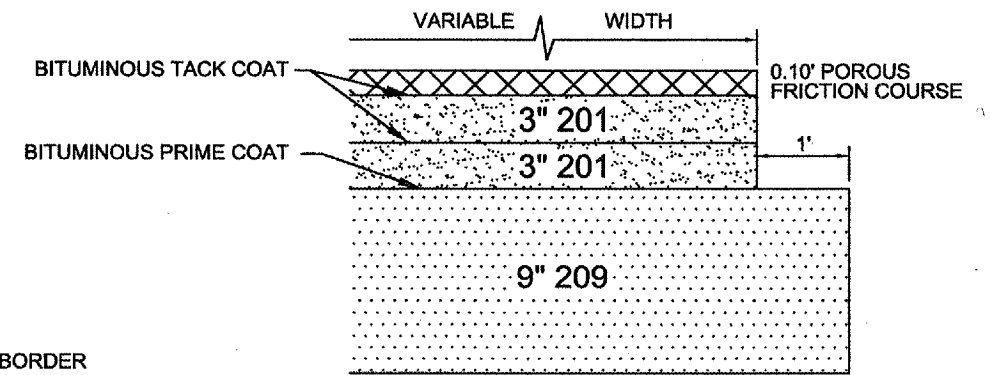

RUNWAY 6 TURNAROUND WIDENING DETAIL

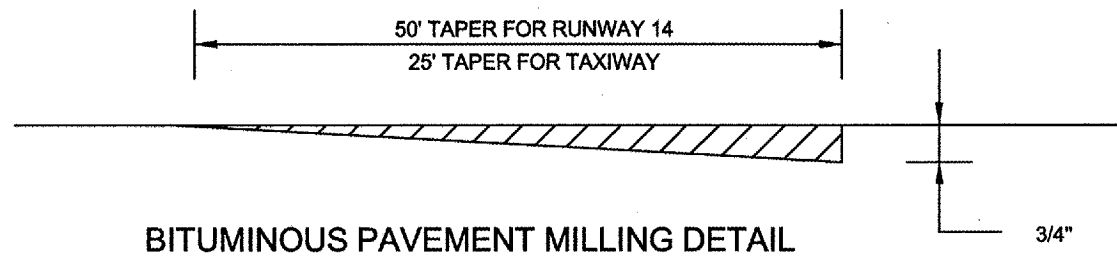

BITUMINOUS PAVEMENT MILLING DETAIL

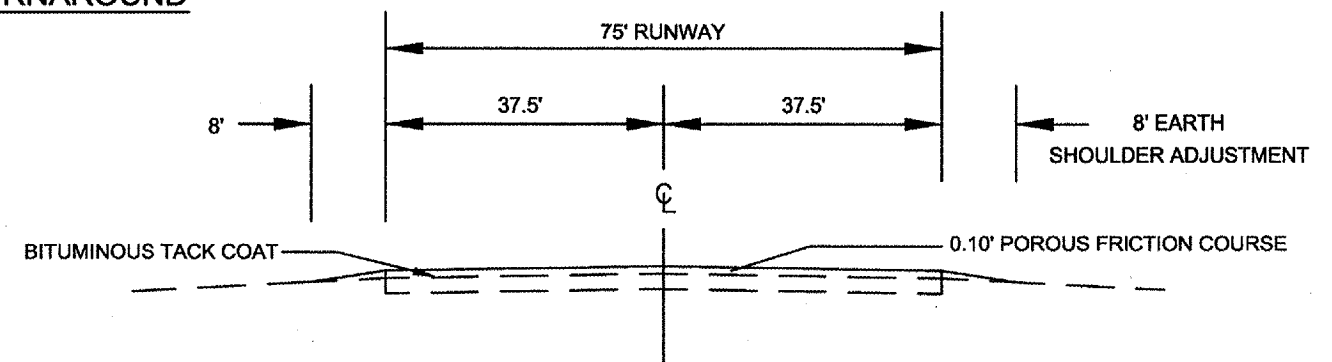

TYPICAL SECTION RUNWAY 6/24 - STATION 12+10 TO 38+03