

**ELECTRICAL SERVICE – PANEL DIAGRAM (TYPICAL FOR POLE AND GROUND MOUNTED SERVICE)
SERVICE INSTALLATION POLE MOUNT (SHOWN)
(NOT TO SCALE)**

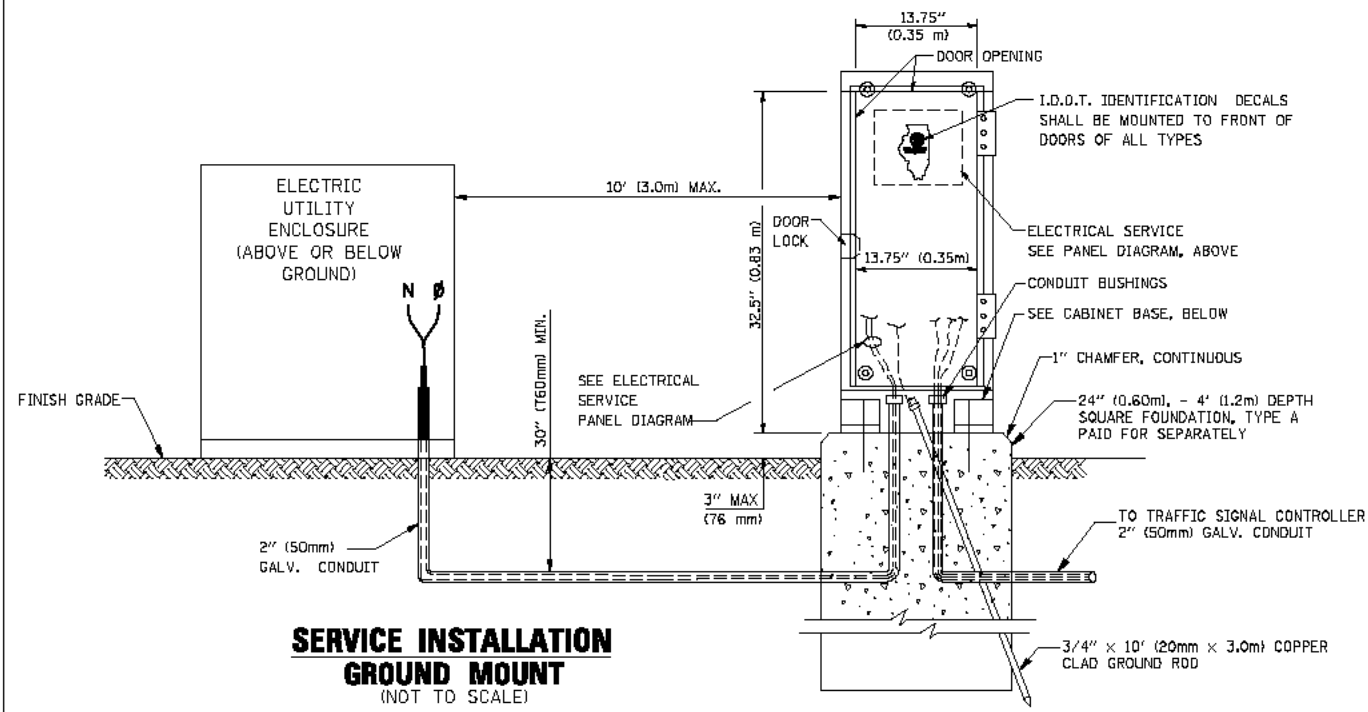

CABINET – BASE BOLT PATTERN (NOT TO SCALE)

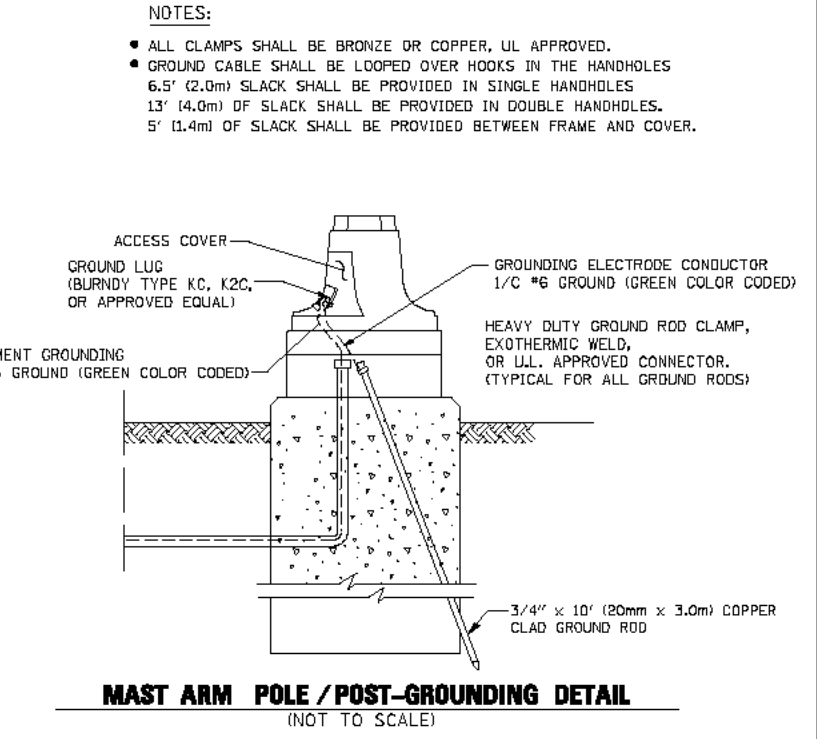
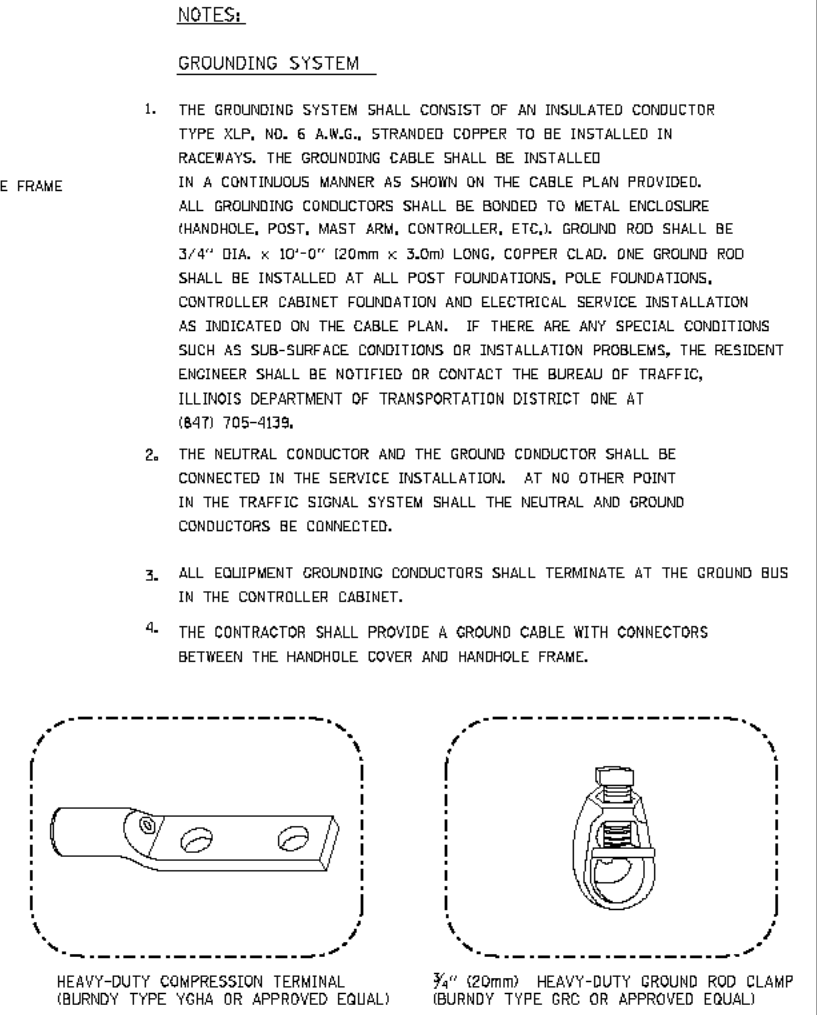
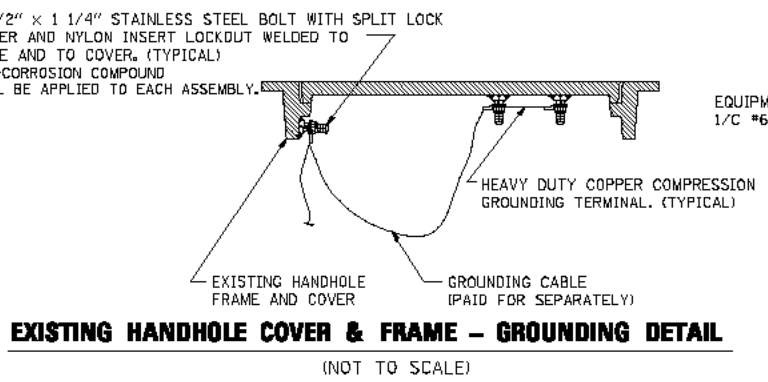
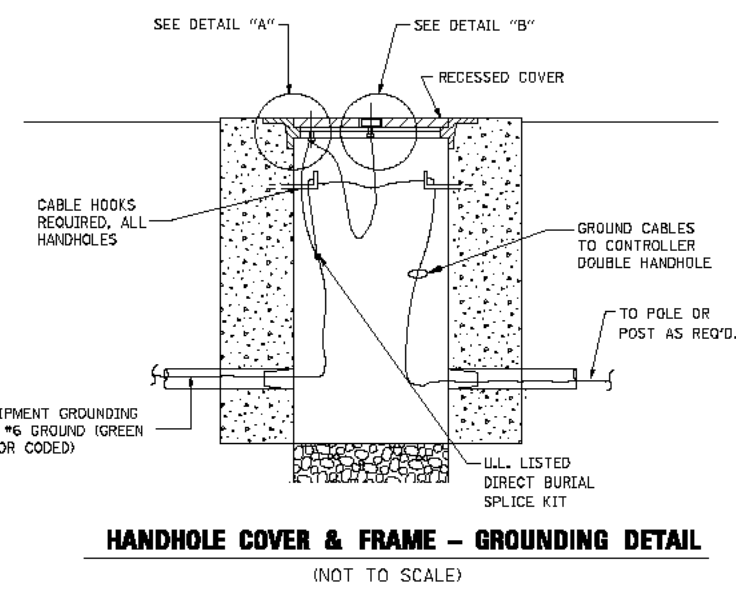
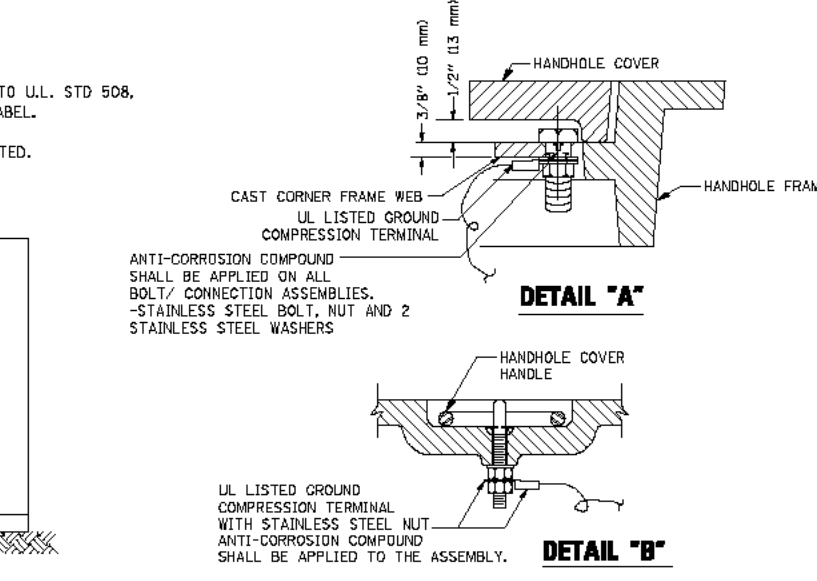
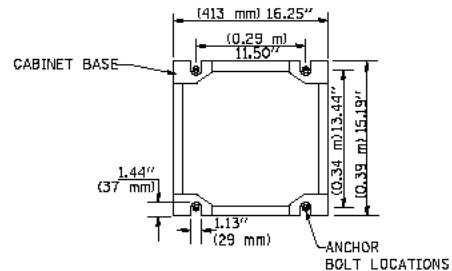

FILE NAME =	USER NAME = kenthaphixaybc	DESIGNED - DAD	REVISED -
al\pwwork\PIW\DOT\KANTHAPHIXAYBC\0112814\traffsig.legend.v7.dgn		DRAWN - BCK	REVISED -
		CHECKED - DAD	REVISED -
		DATE - 10/28/09	REVISED -

**STATE OF ILLINOIS
DEPARTMENT OF TRANSPORTATION**

DISTRICT 1
STANDARD TRAFFIC SIGNAL DESIGN DETAILS

F.A.P. RTE. 305	SECTION 2011-020-TS	COUNTY MCHENRY	TOTAL SHEETS 20	SHEET NO. 6
SCALE:		SHEET NO. 3 OF 6 SHEETS	STA. TO STA.	CONTRACT NO. 60P15
FED. ROAD DIST. NO.		ILLINOIS FED. AID PROJECT		