

EXISTING TYPICAL SECTION
STA 101+28 TO STA 118+45, INDIANWOOD BOULEVARD

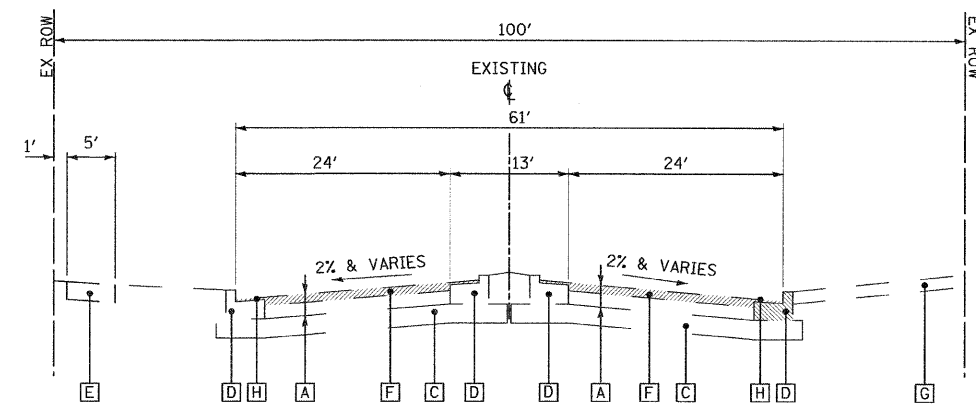

EXISTING TYPICAL SECTION
STA 119+45 TO STA 131+19, INDIANWOOD BOULEVARD

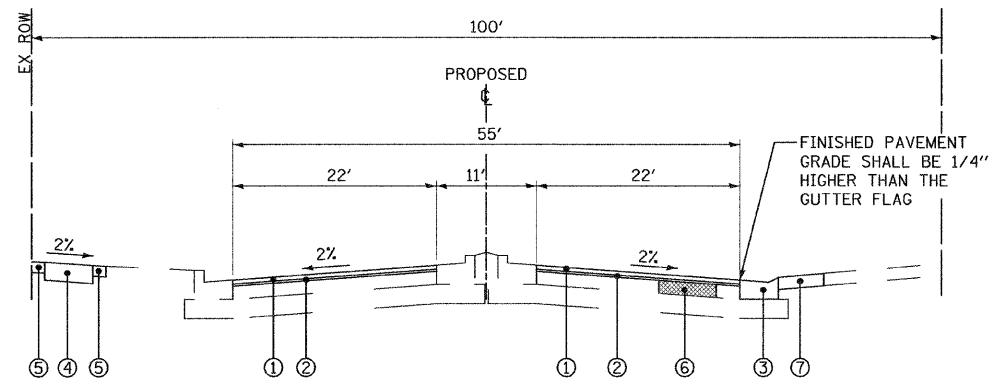

PROPOSED TYPICAL SECTION
STA 101+28 TO STA 118+45, INDIANWOOD BOULEVARD

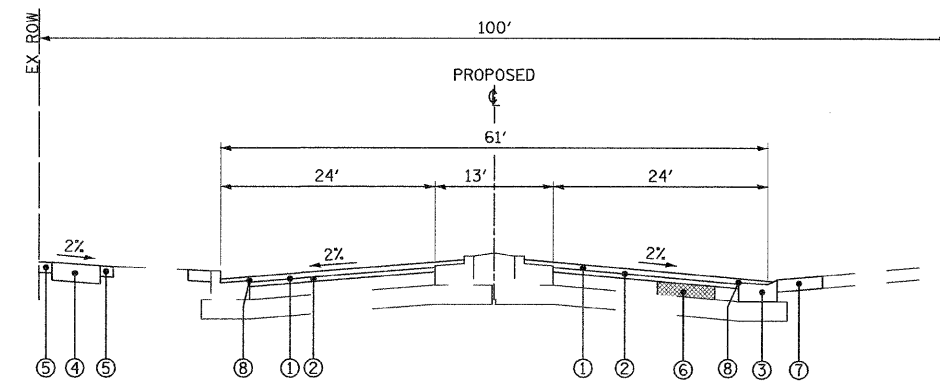

PROPOSED TYPICAL SECTION
STA 119+45 TO STA 131+19, INDIANWOOD BOULEVARD

LEGEND

EXISTING

- A** HMA PAVEMENT
- B** PCC BASE COURSE
- C** AGGREGATE BASE COURSE
- D** COMBINATION CONCRETE CURB AND GUTTER
- E** SIDEWALK
- F** HOT-MIX ASPHALT SURFACE REMOVAL, 2 1/4"
- G** DRIVEWAY
- H** HOT-MIX ASPHALT SURFACE REMOVAL (SPECIAL)

PROPOSED

- 1** HMA SURFACE COURSE, MIX "D", N50 - 1 1/2"
- 2** POLYMERIZED LEVELING BINDER (MACHINE METHOD), N50 - 3/4"
- 3** COMBINATION CONCRETE CURB AND GUTTER REMOVAL AND REPLACEMENT (AS DETERMINED BY ENGINEER)
- 4** SIDEWALK REMOVAL
- 5** PARKWAY RESTORATION
- 6** CLASS D PATCHES (AS DETERMINED BY THE ENGINEER)
- 7** DRIVEWAY REMOVE AND REPLACE (AS DETERMINED BY THE ENGINEER)
- 8** STRIP REFLECTIVE CRACK CONTROL

HOT-MIX ASPHALT MIXTURE REQUIREMENTS

NOTE: CONTRACTOR SHALL MILL BEFORE PATCHING

ITEM	AIR VOIDS @ Ndes
RESURFACING	
HOT-MIX ASPHALT SURFACE COURSE, MIX "D", N50 (IL-9.5 mm) - 1 1/2"	4% @ 50 Gyr
POLYMERIZED LEVELING BINDER (MACHINE METHOD) IL-4.75, N50 - 3/4"	3.5% @ 50 Gyr
PATCHING	
CLASS D PATCH TYPE III & IV (HMA BINDER IL-19 mm) - 6" (2 LIFTS)	4% @ 70 Gyr
DRIVEWAY	
HOT-MIX ASPHALT SURFACE COURSE, MIX "D", N50 (IL-9.5 mm) - 3" (2 LIFTS)	4% @ 50 Gyr

1. THE UNIT WEIGHT USED TO CALCULATE ALL HOT-MIX ASPHALT SURFACE MIXTURE QUANTITIES IS 112 LBS/50 YD/IN.
2. THE "AC TYPE" FOR POLYMERIZED HMA MIXES SHALL BE "SBS/SBR PG 76-22" AND FOR NON-POLYMERIZED HMA THE "AC TYPE" SHALL BE "PG 64-22" UNLESS MODIFIED BY DISTRICT ONE SPECIAL PROVISIONS. FOR "PERCENT OF RAP" SEE DISTRICT ONE SPECIAL PROVISIONS.

COPYRIGHT © 2011 BY BAXTER & WOODMAN, INC.
 STATE OF ILLINOIS PROFESSIONAL DESIGN FIRM
 5860 W. 119th Street, Moline, IL 61704
 309/791-1111 FAX 309/791-1112



DESIGNED - TMS	REVISED -
DRAWN - KAR	REVISED -
CHECKED - JJF	REVISED -
DATE - 10-26-11	FILE - 091213-TypSec.shrt

STATE OF ILLINOIS
DEPARTMENT OF TRANSPORTATION

TYPICAL SECTIONS AND
HMA MIXTURE REQUIREMENTS

SCALE: NONE

STA. TO STA.

*1055/1056

F.A.U. RTE.	SECTION	COUNTY	TOTAL SHEETS	SHEET NO.
*	11-00095-00-RS	COOK	27	5
FED. ROAD DIST. NO.			CONTRACT NO. 63690	
ILLINOIS/FED. AID PROJECT M-9003969				