

EXISTING TYPICAL SECTION
STA 131+19 TO STA 141+39, INDIANWOOD BOULEVARD

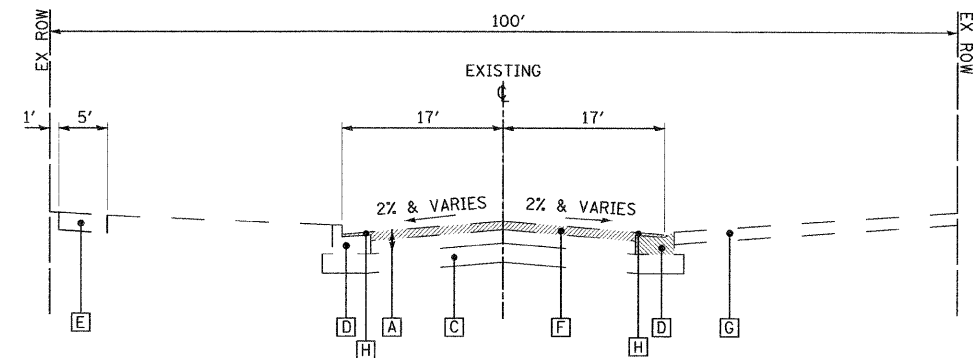

EXISTING TYPICAL SECTION
STA 10+78 TO STA 59+62, LAKEWOOD BOULEVARD

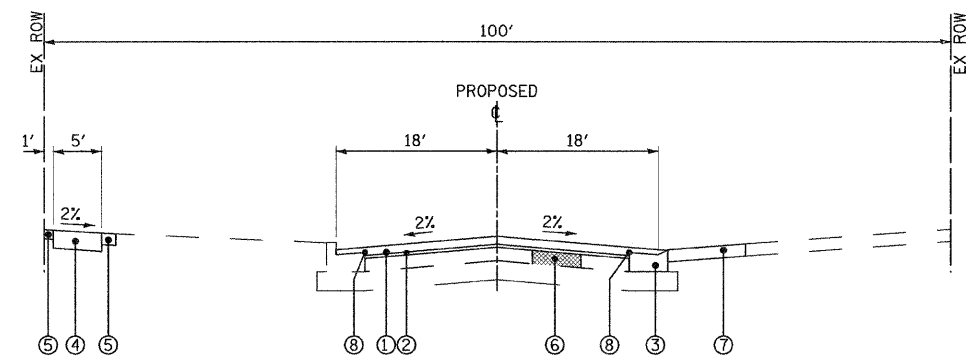

PROPOSED TYPICAL SECTION
STA 131+19 TO STA 141+39, INDIANWOOD DRIVE

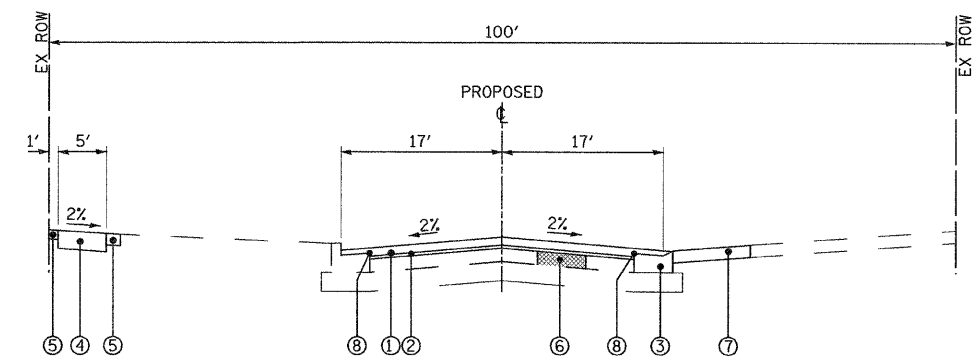

PROPOSED TYPICAL SECTION
STA 10+78 TO STA 59+62, LAKEWOOD BOULEVARD

LEGEND

EXISTING

- A HMA PAVEMENT
- B PCC BASE COURSE
- C AGGREGATE BASE COURSE
- D COMBINATION CONCRETE CURB AND GUTTER
- E SIDEWALK
- F HOT-MIX ASPHALT SURFACE REMOVAL, 2 1/4"
- G DRIVEWAY
- H HOT-MIX ASPHALT SURFACE REMOVAL (SPECIAL)

PROPOSED

- 1 HMA SURFACE COURSE, MIX "D", N50 - 1 1/2"
- 2 POLYMERIZED LEVELING BINDER (MACHINE METHOD), N50 - 3/4"
- 3 COMBINATION CONCRETE CURB AND GUTTER REMOVAL AND REPLACEMENT (AS DETERMINED BY ENGINEER)
- 4 SIDEWALK REMOVAL
- 5 PARKWAY RESTORATION
- 6 CLASS D PATCHES (AS DETERMINED BY THE ENGINEER)
- 7 DRIVEWAY REMOVE AND REPLACE (AS DETERMINED BY THE ENGINEER)
- 8 STRIP REFLECTIVE CRACK CONTROL

COPYRIGHT © 2011 BY BAXTER & WOODMAN, INC.
 STATE OF ILLINOIS - PROFESSIONAL DESIGN FIRM
 LICENSE NO. - 84-2782/2012
 5600000
 PROJECT NO. - 11-00095-00-RS
 DRAWING NO. - 11-00095-00-RS-TYP
 DATE - 10/26/11
 FILE - 091213-TypSec.sht



DESIGNED	TMS	REVISED	-
DRAWN	KAR	REVISED	-
CHECKED	JJF	REVISED	-
DATE	10-26-11	FILE	091213-TypSec.sht

STATE OF ILLINOIS
DEPARTMENT OF TRANSPORTATION

TYPICAL SECTIONS AND
HMA MIXTURE REQUIREMENTS

SCALE: NONE

STA. TO STA.

*1055/1056

F.A.U. RTE.	SECTION	COUNTY	TOTAL SHEETS	SHEET NO.
.	11-00095-00-RS	COOK	27	6
FED. ROAD DIST. NO. ILLINOIS/FED. AID PROJECT M-90031969			CONTRACT NO. 63690	